



New Brunswick™ Innova® 40/40R Shaker

Operating Manual

Copyright ©2022 Eppendorf SE, Germany. All rights reserved, including graphics and images. No part of this publication may be reproduced without the prior permission of the copyright owner.

Allen® is a registered trademark of Allen Manufacturing Company, USA.

Eppendorf® and the Eppendorf Brand Design are registered trademarks of Eppendorf SE, Germany.

Innova® is a registered trademark of Eppendorf, Inc., USA.

New Brunswick™ is a trademark of Eppendorf SE, Germany.

Trademarks are not marked in all cases with ™ or ® in this manual.

DOMINIQUE DUTSCHER SAS

Table of contents

1	Operating instructions	7
1.1	Using this manual	7
1.2	Danger symbols and danger levels	7
1.2.1	Danger symbols	7
1.2.2	Danger levels	7
1.3	Symbols used	8
1.4	Abbreviations used	8
2	Safety	9
2.1	Intended use	9
2.2	User profile	9
2.3	Application limits	9
2.4	Information on product liability	9
2.5	Warnings for intended use	10
2.5.1	Personal injury or damage to the device	10
3	Product description	13
3.1	Product overview	13
3.2	Delivery package	14
3.3	Features	14
3.4	Software interfaces	16
3.5	Drip pan reservoir	16
3.6	Heater	16
3.7	Alarms	17
3.8	Remote alarm (optional)	17
4	Installation	19
4.1	Selecting the location	19
4.2	Unpacking the device	20
4.3	Install the platform	20
4.4	Install flask clamp	22
4.5	Connecting to mains/power supply	23
5	Operation	25
5.1	Operating controls	25
5.2	Powering on	25
5.3	Operation	26
5.4	Changing screens	27
5.4.1	Screen names and descriptions	27
5.4.2	Choose screens	28
5.5	Opening the lid	28
5.6	Display Screen	29
5.6.1	Changing displayed parameters	29
5.6.2	Viewing the setpoints	30
5.6.3	Changing the setpoints	30
5.7	Summary screen	31
5.7.1	Changing setpoint values in the summary screen	31

Table of contents

New Brunswick™ Innova®40/40R Shaker
English (EN)

5.8	Setup screen	32
5.8.1	Changing the day	32
5.8.2	Changing the time	33
5.8.3	To lock the settings	33
5.8.4	To mute the audible alarm	33
5.9	RS-232 screen	34
5.9.1	Changing the communication mode	34
5.9.2	Changing the baud rate	35
5.10	Calibrate screen	35
5.10.1	Temperature offset	35
5.10.2	Calculating the temperature offset	36
5.10.3	Creating the temperature offset	36
5.10.4	Calibrating the shaking speed	36
5.11	Programs screen	37
5.11.1	Create a program	37
5.11.2	Save the program	39
5.11.3	Edit a program	39
5.11.4	Run and stop a program	39
5.12	Program the timer	39
5.13	Power interruption	40
6	Troubleshooting	41
6.1	Troubleshooting	41
7	Maintenance	43
7.1	Routine maintenance	43
7.2	Cleaning external and internal surfaces	43
7.3	Biohazard decontamination	44
8	Technical data	45
8.1	Specifications	45
8.1.1	Agitation	45
8.1.2	Temperature system	45
8.1.3	Power supply	46
8.1.4	Ambient conditions	46
8.1.5	Dimensions and weight	46
8.1.6	Alarms	46
8.1.7	Display	46
8.1.8	RS-232	47
8.1.9	Compliance and Certifications	47
8.1.10	CE Directives and Standards	47
8.2	Certifications	47

9	Ordering Information	49
9.1	Replacement parts	49
9.2	Accessories	49
9.2.1	Platforms	49
9.2.2	Replacement clamp hardware kits	50
9.2.3	Test tube racks and other accessories	51
10	Transport, storage and disposal	53
10.1	Disposal	53
	Index	54
	Certificates	57

DOMINIQUE DUTSCHER SAS

DOMINIQUE DUTSCHER SAS

1 Operating instructions








1.1 Using this manual

- ▶ Read this operating manual completely before using the device for the first time. Also observe the instructions for use of the accessories.
- ▶ This operating manual is part of the product. Thus, it must always be easily accessible.
- ▶ Enclose this operating manual when transferring the device to third parties.
- ▶ You will find the current version of the operating manual for all available languages on our website www.eppendorf.com.

1.2 Danger symbols and danger levels

The safety instructions of this operating manual indicate the following danger symbols and danger levels:

1.2.1 Danger symbols

	Electric shock		Explosion
	Material damage		Hazard point
	Heavy loads		Biohazard
	Burns		


1.2.2 Danger levels

DANGER	<i>Will</i> lead to severe injuries or death.
WARNING	<i>May</i> lead to severe injuries or death.
CAUTION	May lead to light to moderate injuries.
NOTICE	May lead to material damage.

Operating instructions

New Brunswick™ Innova®40/40R Shaker
English (EN)

1.3 Symbols used

Example	Meaning
▶	You are requested to perform an action.
1. 2.	Perform these actions in the sequence described.
•	List.
	References useful information.

1.4 Abbreviations used

°C
Degree Celsius

cm
Centimeter

h
Hour

Hz
Hertz

kg
Kilogram

L
Liter

lb
Pound

in
Inch

min
Minute

mL
Milliliter

mm
Millimeter

rpm
Revolutions per Minute

s
Second

V
Volt

VA
Volt Ampere

2 Safety

2.1 Intended use

The device is used for uniform movement and temperature control of biological solutions and cultures in reaction vessels.

The device is exclusively intended for use indoors. All country-specific safety requirements for operating electrical equipment in the laboratory must be observed.

2.2 User profile

The device may only be operated by trained lab personnel who have carefully read the operating manual and are familiar with the device functions.

2.3 Application limits



DANGER! Risk of explosion.

- ▶ Do not use the device in an explosive atmosphere.
- ▶ Do not operate the device in areas where work with explosive substances is carried out.
- ▶ Do not use the device to process any explosive or highly reactive substances.
- ▶ Do not use the device to process any substances which could generate an explosive atmosphere.

Due to its design and the ambient conditions in its interior, the device is not suitable for use in potentially explosive atmospheres.

The device may only be used in a safe environment, e.g., the open atmosphere of a ventilated lab. The use of substances which may contribute to a potentially explosive atmosphere is not permitted. The final decision on risks associated with the use of such substances lies with the user.

2.4 Information on product liability

In the following cases, the designated protection of the device may be compromised.

The liability for the function of the device passes to the operator if:

- The device is not used in accordance with this operating manual.
- The device is used outside of the range of application described in the succeeding chapters.
- The device is used with accessories or consumables that were not approved by Eppendorf.
- Service or maintenance is completed on the device by people who are not authorized by Eppendorf.
- The owner has made unauthorized modifications to the device.

Safety

New Brunswick™ Innova®40/40R Shaker
English (EN)

2.5 Warnings for intended use

Read the operating manual and observe the general safety instructions before using the device.

2.5.1 Personal injury or damage to the device

**WARNING! Risk of explosion and injury or death**

- ▶ Do not use equipment with flammable substances or organisms with flammable by-products.

**WARNING! Risk of electric shock and/or damage to unit**

- ▶ Check that the voltage and frequency of your unit are compatible with mains/power supply.
- ▶ Remove caution label from back of unit.
- ▶ Set the circuit breaker on the right side of the unit to the OFF position.

**WARNING! Risk of electric shock and/or damage to device**

- ▶ Use a grounded power supply.

**WARNING! Risk of electric shock and/or damage to the device**

- ▶ Before cleaning device, turn off and unplug from mains/power supply.

**WARNING! Risk of electric shock when replacing fuses**

- ▶ Turn off shaker and disconnect from mains/power supply.

**CAUTION! Lack of safety due to incorrect accessories or spare parts**

Accessories and spare parts that are not recommended by Eppendorf compromise the safety, function, and precision of the device. Eppendorf cannot be held liable or accept any liability for damage resulting from the use of non-recommended accessories and spare parts.

- ▶ Only use accessories and original spare parts recommended by Eppendorf.

**WARNING! Injury from hazardous biological material**

- ▶ Use respiratory protection when cleaning spills where aerosolization is suspected.
- ▶ Wear gloves, safety glasses, and laboratory coat when cleaning.

**WARNING! Burns due to hot metal on the device and hot pistons**

- ▶ Only touch the device and pistons when wearing protective gloves.



WARNING! Heavy

- ▶ Do not attempt to lift the Innova 40/40R by yourself.
- ▶ Ask for assistance or use suitable equipment when raising or handling the device.



CAUTION! Risk of injury and/or damage to unit

- ▶ A minimum load is required to safely operate the Innova 40/40R Shaker.
- ▶ Make sure the unit has a minimum load of 6.4 kg (14 lb) so that it can safely operate under the maximum speed (500 rpm). This includes the weight of the platform, flasks, and media.



NOTICE! Damage to device

- ▶ Never run shaker without a platform.

DOMINIQUE DUTSCHER SAS

Safety

New Brunswick™ Innova®40/40R Shaker
English (EN)

DOMINIQUE DUTSCHER SAS

3 Product description

3.1 Product overview

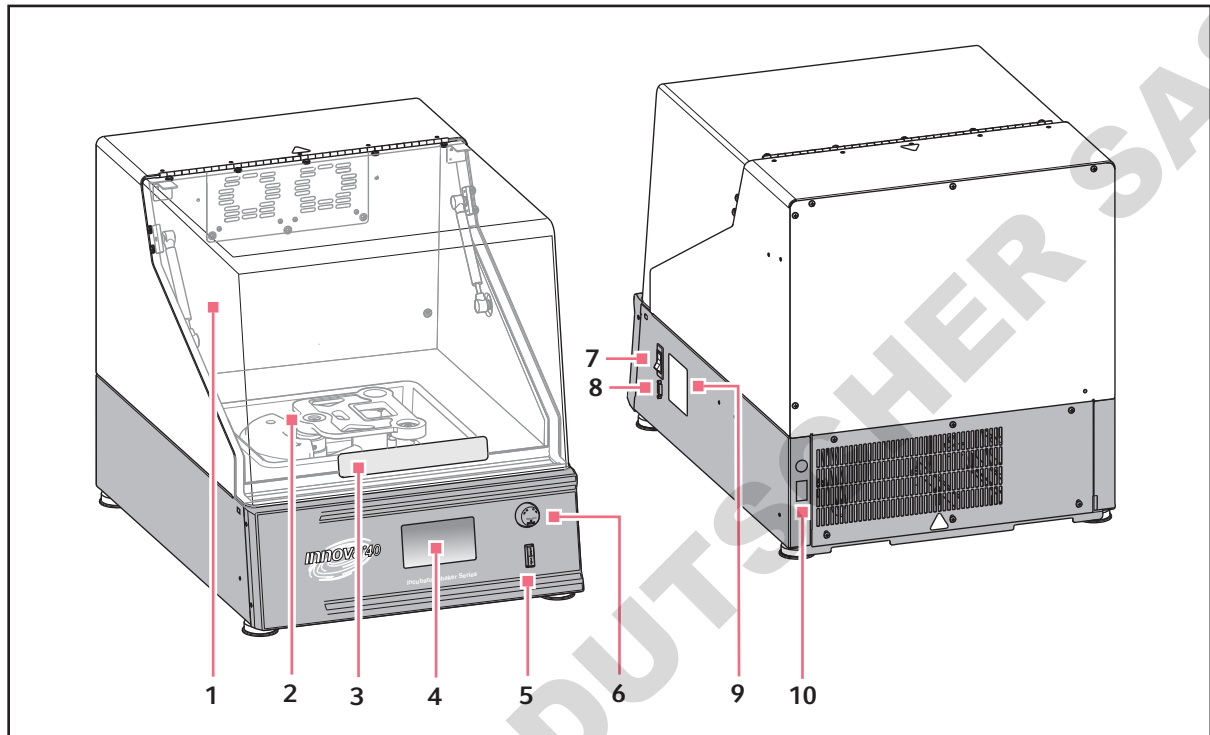


Fig. 3-1: Front and rear view of the 40/40R

- | | |
|--|---|
| 1 Lid
With automatic stop function | 6 Control knob
Changes screens and selects operating conditions |
| 2 Drive
Triple eccentric drive - orbit is model-dependent | 7 Mains/Power switch
Switch device on or off (circuit breaker that turns power on and off to the entire device) |
| 3 Lid handle | 8 RS-232 interface
Read out parameter values and control operational functions using computer applications |
| 4 Display
Graphical user interface with display of parameters and parameter values | 9 Name plate
Model number, documentation number, serial number and electrical connection data |
| 5 Start/Stop switch
Starts and stops shaking | 10 Mains/Power connection
Connect the power cable |

Product description

New Brunswick™ Innova®40/40R Shaker
English (EN)

3.2 Delivery package

NOTE: Use of the Innova 40/40R requires a platform, which is a separate item (see *Platforms on p. 49*).

**WARNING! Heavy**

- ▶ Do not attempt to lift the Innova 40/40R by yourself.
- ▶ Always ask for assistance or use a lifter or other suitable equipment when raising or handling the unit.



- ▶ Check the delivery package for completeness.
- ▶ Check all parts for damage in transit.
- ▶ Retain the shipping box and packing material for subsequent storage or transport of the device.

3.3 Features

The Innova 40/40R is a benchtop orbital shaker that uses a triple eccentric counterbalanced drive mechanism.

Operation

The Innova 40/40R may be operated in the following ways:

- *Continuously:* at a set speed and temperature, until user stops device.
- *Timed mode:* run at a set speed, time, and temperature, after which the shaker automatically shuts off.
- *Shaker's programmable controller:* run through multiple temperature and speed changes for an extended period of time.
- *Computer through an RS-232 interface.*

Orbit

- Horizontal plane rotary motion.
- Available in 1.9 cm (3/4 in) or 2.5 cm (1 in) diameter circular orbit.

Refrigeration (40R only)

The refrigeration system in the 40R is a variable-capacity system designed with self-checks to maintain the setpoint, to balance pressure within the system, and to keep the evaporator from freezing.

When the shaker is powered up, there is a 4 min time delay prior to compressor start-up.

Temperature control

Ambient temperature is measured at 1 m from the exterior of the unit.

- 40R provides temperature control from 15 °C below ambient temperature to 80 °C with a minimum setpoint of 4 °C.
- 40 provides temperature control from 5 °C above ambient temperature to 80 °C.

Both these ranges depend on relative humidity and other ambient factors, as well as the options installed on the device.

Safety

- Drive Interrupt shuts off power to shaker when lid opens.
- Acceleration/deceleration circuit prevents sudden starts and stops, minimizing both splashing and mechanical damage.
- Independent mechanical sensing switch also shuts the motor off in unbalanced condition.

Alarms

Innova 40/40R is equipped with visual and audible alarms that alert the user to the following conditions:

- The end of a timed run.
- Deviations from speed setpoint.
- Deviations from temperature setpoint.
- Mains/power failure.
- Lid is open.

Platforms

To accommodate customer needs, a wide variety of platforms can be used with the Innova 40/40R (see *Platforms on p. 49*):

- Universal platforms are the most flexible, providing hole patterns for flask clamps, test tube racks and other accessories.
- Dedicated platforms are supplied with 1 size flask clamps attached.

Flasks/Tubes

Erlenmeyer flasks (up to 3 L), and a wide variety of tubes and plates can be accommodated using the Eppendorf shaker accessories (see *Accessories on p. 49*).

Other accessories

Test tube racks, microplate holders, and test tube rack holders, as well as sticky pad and sticky tape are also available (a universal platform is needed for all test tube racks and holders) (see *Accessories on p. 49*).

Product description

New Brunswick™ Innova®40/40R Shaker
English (EN)

3.4 Software interfaces

The RS-232 port is located below the **Mains/Power switch** on the right side of the control panel. It can be used to connect a computer to the shaker for control of operating conditions or data logging applications


!Invalid cross reference to: D-NBS-007187.1

The customer is responsible for securing the proper driver to interface with the RS-232.

3.5 Drip pan reservoir

The Innova 40/40R is equipped with a plastic liner to protect the electronics and temperature controls. An optional drip pan (M1250-9906) is recommended to protect the drive mechanism in case of accidental spills and/or broken glassware.

3.6 Heater

When the heater is on, the heater on icon appears in the display . The heater automatically stops running when the lid is opened.

The heater has the following features:

- 1000 ohm platinum RTD.
- Pulse width modulation on a 2.5 s duty cycle (this cycle time is fast enough to prevent noticeable changes in air temperature).
- Long-life, low-watt density resistance-type heater with high temperature thermostat.

3.7 Alarms

If an alarm condition exists, the field in the lower right corner alternates the day and time with characters indicating the nature of the alarm condition, accompanied by an audible alarm (unless muted) (see *Setup screen on p. 32*).

Tab. 3-1: Alarm descriptions

Indication	Description
TEMP	<ul style="list-style-type: none"> • Indicates that the temperature has deviated more than ± 1 °C from setpoint after achieving control temperature range. • After door is opened, alarm is disabled for 5 min while chamber recovers to setpoint.
RPM	<ul style="list-style-type: none"> • Indicates that the speed has deviated more than ± 5 rpm from setpoint after achieving operating speed setpoint. • After door is opened, alarm is disabled for 5 min while chamber recovers to setpoint.
POWER	<ul style="list-style-type: none"> • Indicates that the unit is powering up (both at normal power-up and after power interruption); flashes until the control knob is moved.
HRS	<ul style="list-style-type: none"> • Indicates when timed run is completed.

3.8 Remote alarm (optional)

The Innova 40/40R can be equipped with a factory-installed remote alarm component (M1320-8029). When it is hooked up to your relay and receiving equipment, this device sends notification of an alarm condition to the remote location you choose.

Product description

New Brunswick™ Innova®40/40R Shaker
English (EN)

DOMINIQUE DUTSCHER SAS

4 Installation

4.1 Selecting the location



WARNING! Heavy

- ▶ Do not attempt to lift the Innova 40/40R by yourself.
- ▶ Ask for assistance or use suitable equipment when raising or handling the device.

Select the location for the device according to the following criteria:

- Suitable power connection.
- Access to RS-232 port.
- Surface where you place the device must be smooth and sturdy.
- Ambient temp of 10 °C – 35 °C.
- Relative humidity of 20 % – 80 %.
- Surrounding area must be well ventilated.
- Allow 7.6 cm (3 in) around shaker for ventilation.
- Up to 2000 m.
- Able to accommodate 90.8 kg (200 lb).

Ensure there is at least this much space for the Innova 40/40R:

Space requirements	Width: 68.6 cm (27 in) Depth: 83.2 cm (33 in) Height: 106.7 cm (42 in)
--------------------	--



Ensure there is enough room to disconnect the shaker from mains/power in case of emergency.

Installation

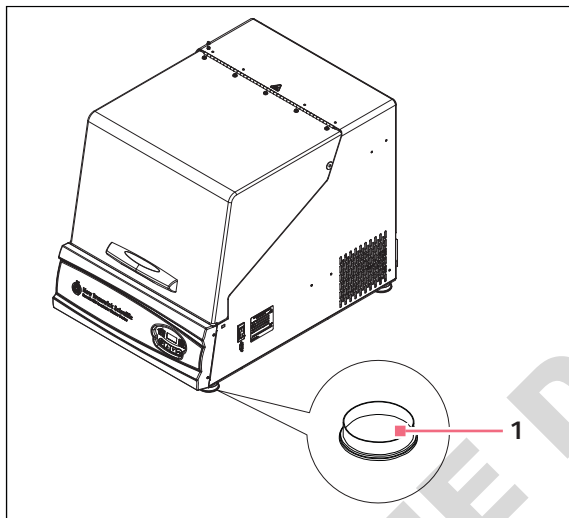
New Brunswick™ Innova®40/40R Shaker
English (EN)

4.2 Unpacking the device

i Keep the packing material and transport securing device for later transport or storage.

1. Remove the packing material.
2. Remove the transport securing device.
3. Use the details included in the scope of delivery to check that the delivery is complete.
4. Check all parts for damage in transit. Contact Eppendorf Service if parts are missing or transport damage is present.

i Before placing the shaker on the bench, be sure to remove the four red plastic feet protectors.



1 Plastic foot protector

During unpacking, remove protectors from each of the four feet on the Innova 40/40R Shaker

4.3 Install the platform

i A platform with typical anticipated clamps and load must be installed prior to use.

The Innova 40/40R can be used with a variety of Eppendorf platforms that accept a wide range of clamps for flasks, test tubes, etc. A platform, which is required for operation, is a separate item, not included with the shaker assembly (see *Platforms on p. 49*).



NOTICE! Damage to device

- ▶ Never run shaker without a platform.

Tools required (provided):

- Allen® key, 4 mm (5/32 in)

A platform must be installed on the device prior to use. To install:

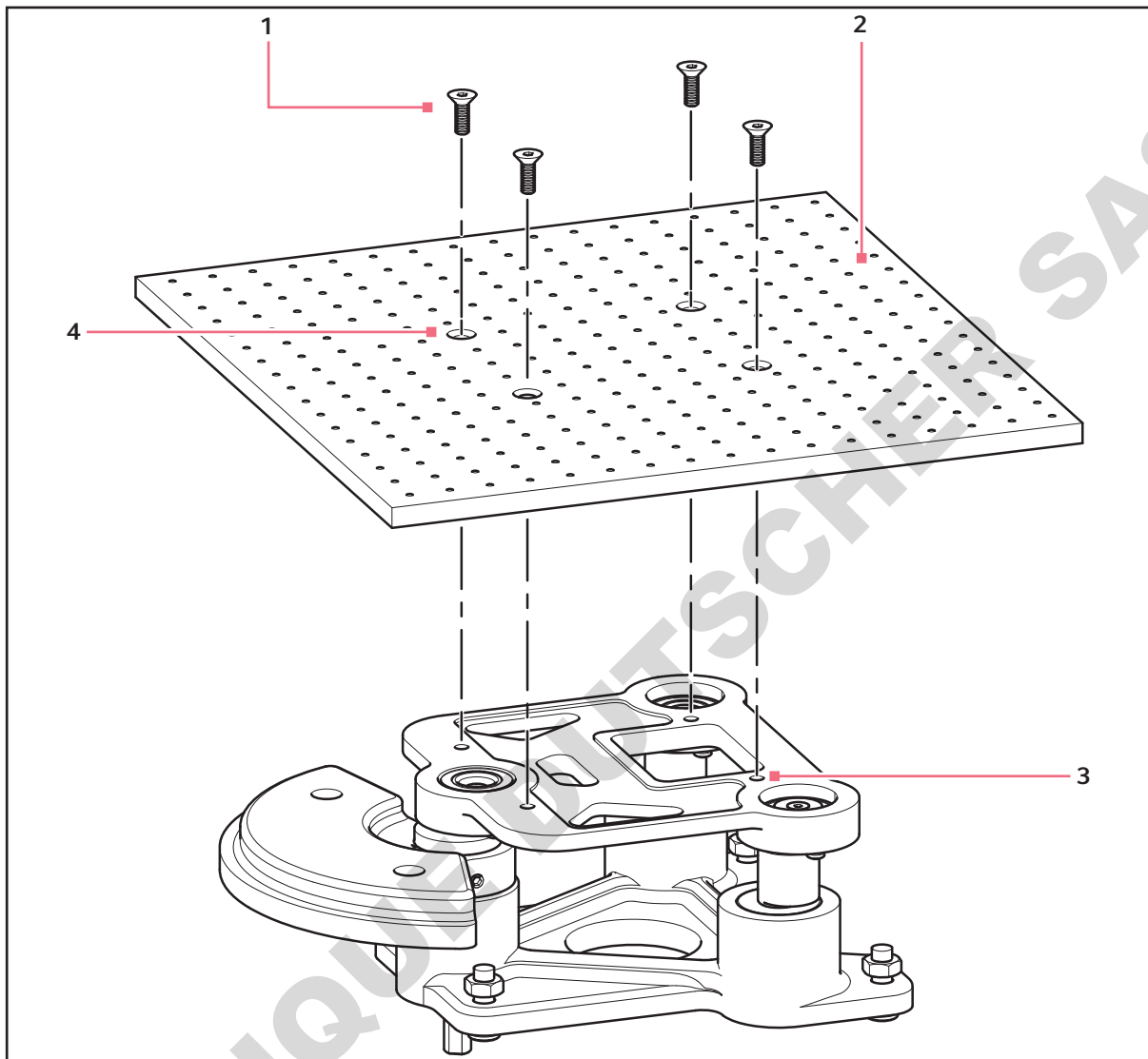


Fig. 4-1: Platform installation

1 Allen screws

2 Platform

3 Platform holes

4 Housing plate holes

1. Set the **Mains/Power switch** off.
2. Open the lid.
3. With the Allen key provided, loosen and remove the 4 Allen screws installed on the top plate of the bearing housing (set screws aside for reuse).
4. Place the platform on top of the plate of the bearing housing and align the holes.
5. Reinstall and secure the 4 screws.

Installation

New Brunswick™ Innova®40/40R Shaker
English (EN)

4.4 Install flask clamp



NOTICE!

- ▶ Do not overfill flasks.



Eppendorf flask clamps are used on a variety of shaker platforms. Flat head screws of different lengths and thread pitch are used to secure the clamp.

Materials needed:

- Phillips screwdriver
- 10 – 24 × 5/16 in (7.9 mm) flat Phillips screws

Flask clamps purchased for use with universal platforms require installation (see *Accessories on p. 49*). Clamps are installed by securing the base of the clamp to the platform with the correct type and number of screws. All clamps are shipped complete with hardware.

Clamps for 2 L and 2.8 L flasks are shipped with an additional girdle to keep the flasks in place. The girdle is an assembly of springs and sections of rubber tubing. One girdle is already in place on the clamp, the other is packed separately.

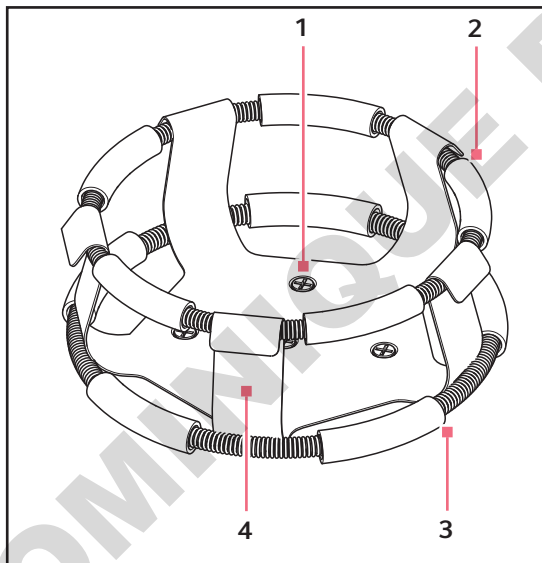


Fig. 4-2: Double girdle clamp

- 1 Clamp mounting holes (with screws)**
- 2 Upper girdle with girdle tubes**
Secures the flask within the clamp.

- 3 Lower girdle with girdle tubes**
Prevents the flask from spinning
- 4 Clamp body (legs and base)**

To install these double girdle clamps:


1. Place the clamp on the platform, aligning its mounting holes with the holes on the platform.
2. Secure the clamp in place using the Phillips screwdriver and screws provided.
3. With the first girdle in place, as delivered, on the upper part of the clamp body, insert an empty flask into the clamp.
4. After making sure the sections of tubing are located between the clamp legs, roll the first girdle down the legs of the clamp as far as it can go.

The tubing sections rest against the platform, and the springs are under the clamp base.

5. Place the second girdle around the upper portion of clamp body (just as the first girdle was initially).
6. Make sure that its spring sections rest against the clamp legs, while its rubber tubing sections sit against the flask, in between the clamp legs.



- 1 L and larger flask clamps are fastened with 5 screws.

Description	Part No.	Quantity	Application
 10 – 24 × 5/16 in (7.9 mm)	S2116-3051	1	5/16 in (7.9 mm) thick aluminum, phenolic, and stainless steel platforms.

4.5 Connecting to mains/power supply



WARNING! Risk of electric shock and/or damage to unit

- ▶ Check that the voltage and frequency of your unit are compatible with mains/power supply.
- ▶ Remove caution label from back of unit.
- ▶ Set the circuit breaker on the right side of the unit to the OFF position.



WARNING! Risk of electric shock and/or damage to device

- ▶ Use a grounded power supply.



CAUTION! Risk of injury and/or damage to unit

- ▶ A minimum load is required to safely operate the Innova 40/40R Shaker.
- ▶ Make sure the unit has a minimum load of 6.4 kg (14 lb) so that it can safely operate under the maximum speed (500 rpm). This includes the weight of the platform, flasks, and media.

- ▶ Only after taking the preceding precautions, plug the power cord into the mains/power supply.

Installation

New Brunswick™ Innova®40/40R Shaker
English (EN)

DOMINIQUE DUTSCHER SAS

5 Operation

5.1 Operating controls

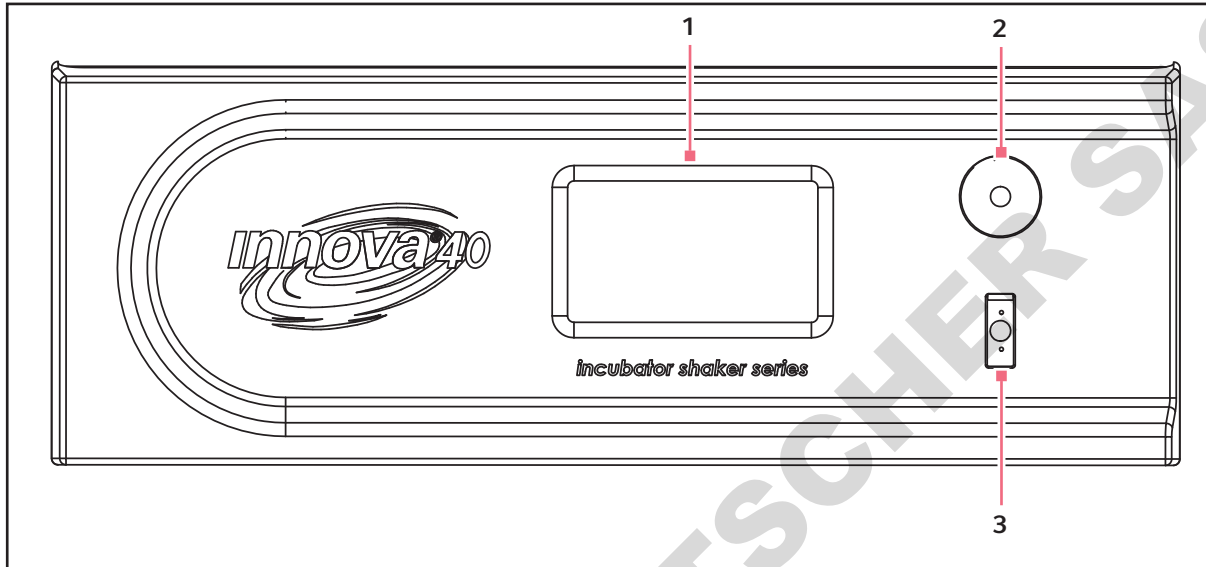


Fig. 5-1: Front panel of Innova 40/40R

1 Display

LCD

2 Control knob

Used to change screens and select operating conditions

3 Start/Stop switch

Stops or starts shaker agitation

Activates timer when using a timed run

5.2 Powering on

1. Close the lid.
2. Turn **Mains/Power switch** to the **On** position.
The display comes on (briefly displaying product information), and then moves into the *DISP* screen. An audible alarm sounds.
3. Turn the **Control knob** to turn alarm off. The audible alarm can be muted (see *Setup screen* on p. 32).

When the shaker begins to operate, the display tracks the speed as it accelerates to the last entered setpoint. The shaking action can be started or stopped by pressing the **Start/Stop switch** on the front panel.



The shaker does not operate if the lid is open. This is indicated by the lid open icon appearing in the bottom line of the display (see Fig. 5-2 on p. 26).

5.3 Operation

When the unit is powered up using the **Start/Stop switch** located on the front panel (see Fig. 5-1 on p. 25), the initial display screen remains on for a short time while the system boots up.

Then the main screen, called *DISP* for Display, appears. This screen indicates the same parameters that were in effect when the power was turned off.

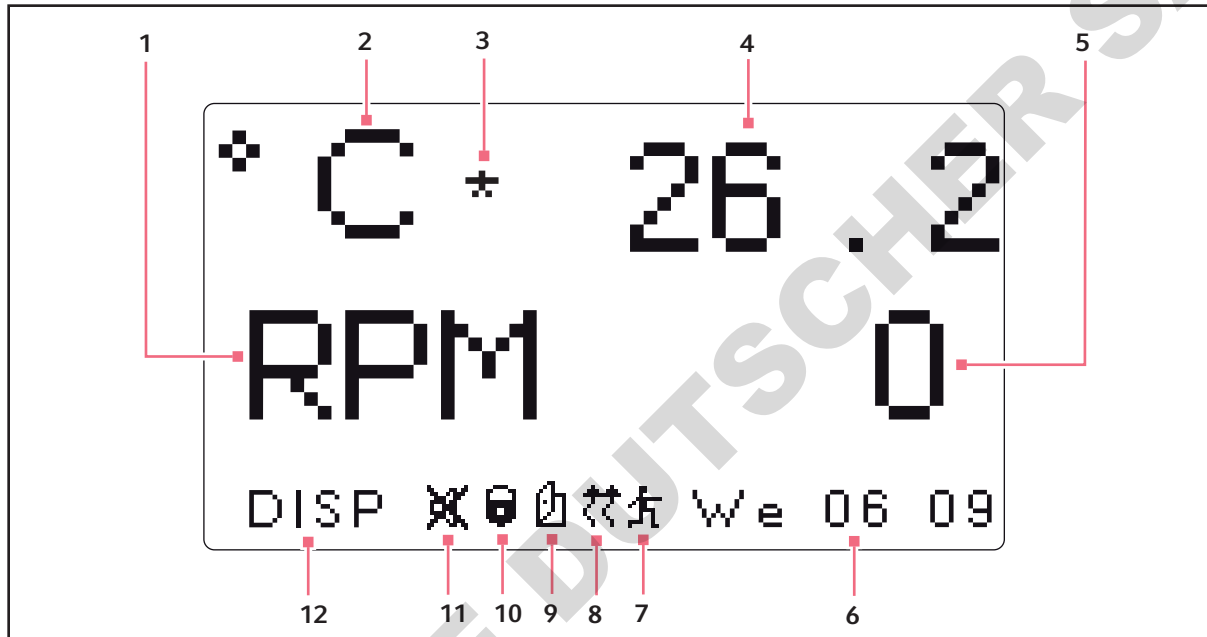


Fig. 5-2: Display screen

1 Speed

Parameters in rpm (revolutions per minute).

2 Temperature

Parameters in degrees Celsius.

3 Temperature offset

This icon appears to the right of °C if the Temperature Offset feature is being used.

4 Temperature

Temperature parameter value

5 Speed

Speed parameter value

6 Day & 24-hour time

7 Program running

Icon appears when user-defined program is running.

8 Heater on

Icon appears when heater is on

9 Lid open

Icon appears when lid is open

10 Parameters locked

This icon appears when the possibility to make manual or programmed parameter changes is disabled (locked). This is controlled by settings on the *SET* screen.

11 Audible alarms muted

Icon appears when audible alarms are muted

12 Screen name

Parameter name and meanings:

Parameter name	Meaning
RPM	Shaking speed, in revolutions per minute.
°C	Chamber temperature, in degrees Celsius.
HRS	Programmed time remaining, in hours.

5.4 Changing screens

5.4.1 Screen names and descriptions

There are 6 screens on the display:

Tab. 5-1: Screen names and descriptions

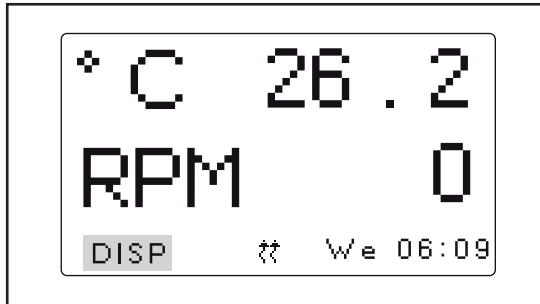
Screen name (displayed in bottom-left corner)	Meaning	Description
<i>DISP</i>	Display	Displays 2 user-selectable parameters and measured values. Changes setpoint values (see <i>Display Screen on p. 29</i>).
<i>SUMM</i>	Summary	Displays all parameters, measured values, and setpoints. Changes all parameters, measured values, and setpoints (see <i>Summary screen on p. 31</i>).
<i>SET</i>	Set	Sets the day of the week, set time, enable or mute alarm, lock, or unlock operating parameters (see <i>Setup screen on p. 32</i>).
<i>COMM</i>	Communication	Sets the communication mode and baud rate (see <i>RS-232 screen on p. 34</i>).
<i>CAL</i>	Calibration	Allows user to enter a temperature offset. Allows user to calibrate speed (see <i>Calibrate screen on p. 35</i>).
<i>PROG</i>	Program	Allows user to set up 1 – 4 programs, each with 1 – 15 steps (see <i>Programs screen on p. 37</i>).

Operation

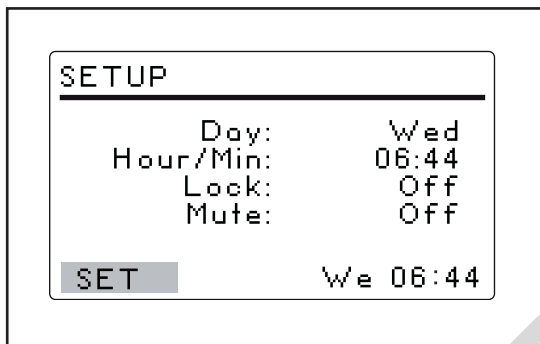
New Brunswick™ Innova®40/40R Shaker
English (EN)

5.4.2 Choose screens

The following example shows changing from the *DISP* (display) screen to the *SET* (setup) screen:



1. Turn the **Control knob** to highlight *DISP* in the bottom-left corner of the screen.
2. Press the **Control knob** until it clicks. *DISP* flashes.



3. Turn the **Control knob** to choose the *SET* screen.
4. Press the **Control knob** until it clicks to save your selection. You changed from the *DISP* screen to the *SET* screen. Repeat the procedure to select any screen.

5.5 Opening the lid

- ▶ Open the lid by grasping the handle and lifting up.
- ▶ When you close the lid, make sure that it closes tightly (shaker does operate until lid is closed all the way).

5.6 Display Screen

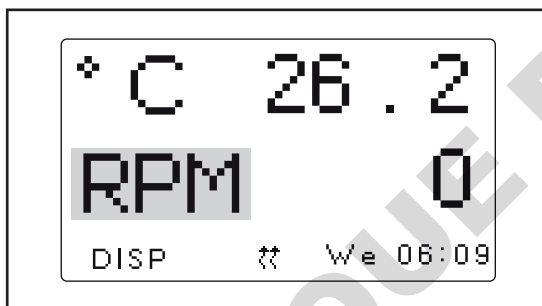
The *DISP* screen displays 2 parameters and the measured values. Use this screen to:

- Change displayed parameters.
- View measured values.
- View and change setpoints.

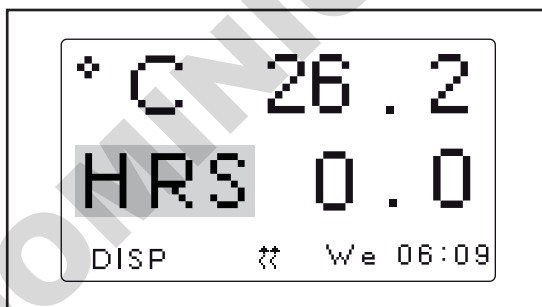


Fig. 5-3: Display screen

5.6.1 Changing displayed parameters



1. Turn **Control knob** to highlight the parameter you wish to replace. This example shows changing the parameter from *RPM* to *HRS*.
2. Press the **Control knob** until it clicks. *RPM* flashes.



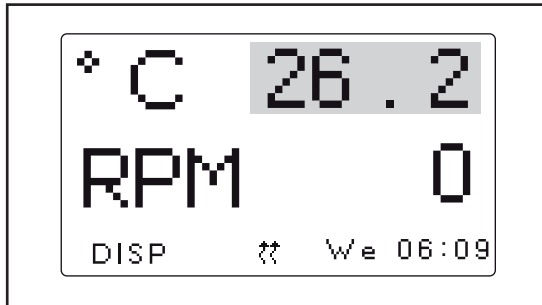
3. Turn the **Control knob** until the desired parameter appears in the highlighted field.
4. Press the **Control knob** to save the parameter.



- If you do not press the **Control knob** to save your selection, after a few seconds the screen reverts to its previous settings.

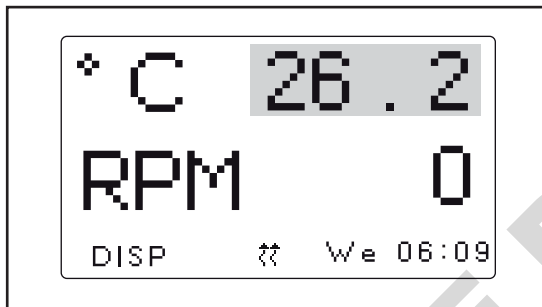
5.6.2 Viewing the setpoints

You can verify the setpoints in the *DISP* screen. The parameter values displayed are the measured values. The setpoint values are user-selected. They may differ depending on many variables.

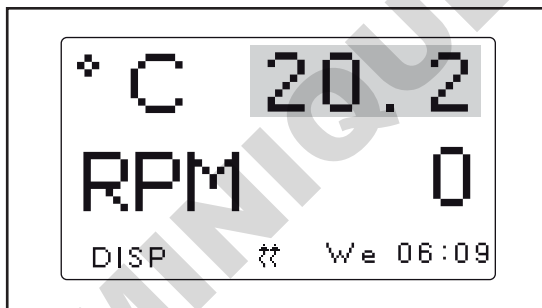


1. Turn the **Control knob** to highlight the actual (measured) parameter value.
2. Press the **Control knob** to display the setpoint. The setpoint flashes.
3. Click **Control knob** in again to return to normal display.

5.6.3 Changing the setpoints



1. Use the **Control knob** to highlight the measured (actual) value (26.2 °C in figure).
2. Press the **Control knob**. The setpoint flashes.



3. Turn the **Control knob** to change the setpoint to desired value (20.2 °C in figure). The **Control knob** changes by increments of (0.1 °C). If you spin the **Control Knob** fast, the value changes by larger increments.
4. Click the **Control knob** in to save the new setpoint. The display automatically returns to the measured actual value.



- If you highlight an item, change it, but do not save your selection, after a few seconds the screen reverts to its previous setting.

5.7 Summary screen

In the *SUMM* (summary) you can see both the, *ACTUAL* (measured) values and the *SET* (user-selected setpoint values).



- *ACTUAL* values are the current measured values in the shaker. You cannot change the values on the screen.
- *SET* values are the values the user selects.

PARAM	ACTUAL	SET
RPM	Off	0
°C	37.1	37.0
HRS	0.0	0.0
SUMM		We 06:44

Fig. 5-4: Summary screen

5.7.1 Changing setpoint values in the summary screen

Like in the *DISP* screen, you can change the setpoints in the *SUMM* screen:

PARAM	ACTUAL	SET
RPM	100	100
°C	37.1	37.0
HRS	0.0	0.0
SUMM		We 06:44

1. Turn the **Control knob** to select the desired setpoint. This example highlights *100* to change the *RPM* setpoint.
2. Click the **Control knob** in. Setpoint value flashes.

PARAM	ACTUAL	SET
RPM	100	110
°C	37.1	37.0
HRS	0.0	0.0
SUMM		We 06:44

3. Turn the **Control knob** clockwise to increase the value or turn counter-clockwise to decrease the value. This example shows changing the setpoint from *100* to *110*.

Click the Control knob in to save the new setpoint value.

4. Repeat the procedure to change the other setpoint values.



- If you turn the **Control knob** but did not save the setpoint value, after a few seconds the screen reverts to its previous settings.

5.8 Setup screen

In the *SET* (setup) screen you can set the day of the week and the time (on a 24 h clock). This screen also allows you to lock all of your settings from further changes, and to mute or enable the audible alarm.

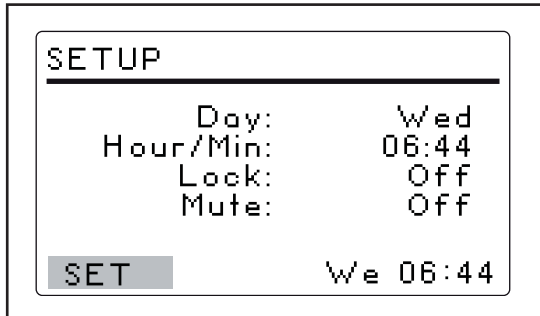
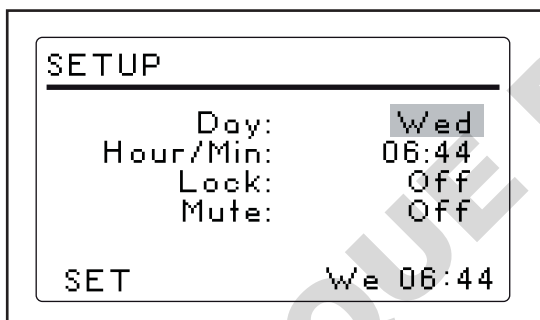


Fig. 5-5: Setup screen

5.8.1 Changing the day

In the *SET* screen:



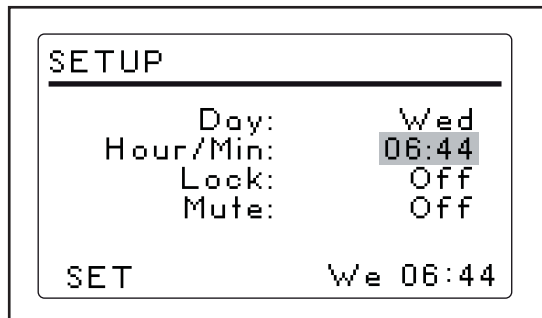
1. Turn the **Control knob** to highlight the day (*Wed* in figure).
2. Press the **Control knob**.
The day flashes.
3. Turn the **Control knob** to select a different day.
4. Press the **Control knob** to save your selection.



- If you do not press the **Control knob** to save your choice, after a few seconds the screen reverts to its previous settings.

5.8.2 Changing the time

In the *SET* screen:



1. Turn the **Control knob** to highlight the time.
2. Press the **Control knob**.
The time (06:44) flashes.
3. Turn the **Control knob** clockwise or counterclockwise to select a different time. Clockwise moves the time forward, counterclockwise moves the time back. One click clockwise or counterclockwise moves the time in 1 min increments. Turning the **Control knob** faster changes the time more rapidly.
4. Press the **Control knob** to save your selection.

5.8.3 To lock the settings

In the *SET* screen:

1. Turn the **Control knob** to highlight the *Lock* status.
2. Press the **Control knob**.
The current status of the *Lock* (*On* or *Off*) flashes.
3. Turn the **Control knob** to select *On* or *Off*.
4. Press the **Control knob** to make a selection.
When you select *On*, the Lock icon appears at the bottom of the screen. This icon remains on display on all screens until you turn the Lock function *Off*.

5.8.4 To mute the audible alarm

In the *SET* screen:

1. Turn the **Control knob** to highlight the *Mute* status (*On* or *Off*).
2. Press the **Control knob**.
The current status of the alarm (*On* or *Off*) flashes.
3. Turn the **Control knob** to select *On* or *Off*.
4. Press the **Control knob** to save your selection.
When you set *Mute* to *On*, the mute icon appears at the bottom of the screen. This icon is displayed on all screens until you turn *Mute* to *Off*.

Operation

New Brunswick™ Innova®40/40R Shaker
English (EN)

5.9 RS-232 screen

This *COMM* screen (communication) is used if you have connected a PC to the RS-232 port. This allows you to record and log data from your shaker. Use the RS-232 screen to:

- Select the RS-232 port *Mode*.
- Select the *Baud Rate* appropriate to your PC.

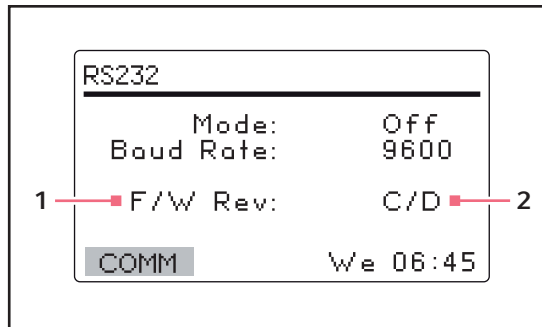


Fig. 5-6: Communication screen

- 1 **FirmWare Revision (this line is for information only).** 2 **In this sample screen, the Display is at Revision C and the FirmWare Control Board at Revision D.**

5.9.1 Changing the communication mode

In the *RS232* screen:

1. Turn the **Control knob** to highlight the *Mode* status.
2. Press the **Control knob**.
The current setting flashes.
3. Turn the **Control knob** to select make your selection.
4. Press the **Control knob** to save your setting.

Tab. 5-2: Communication mode

Mode	Application
<i>Off</i>	The RS-232 port is not open to communication in either direction.
<i>Slave</i>	The shaker can be fully controlled from the computer.
<i>Talk</i>	The shaker sends current value reports to the computer once per minute.
<i>Monit</i> (Monitor)	The shaker responds only to "Report Requests".

5.9.2 Changing the baud rate

In the *RS232* screen:

1. Turn the **Control knob** to highlight the current setting.
The settings are: *9600*, *19200*, and *38400*.
2. Press the **Control knob**.
The current setting flashes.
3. Press the **Control knob** to save your selection.

5.10 Calibrate screen

Use the *CAL* (calibrate) screen to:

- Create a temperature offset.
- Calibrate shaking speed.

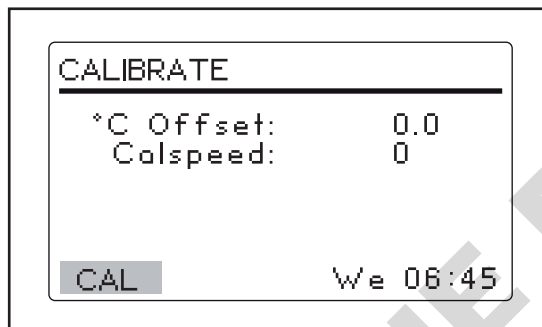


Fig. 5-7: Calibrate screen

5.10.1 Temperature offset

There is a temperature offset function on the Innova 40/40R that allow you to match a reference point temperature inside the chamber with the actual value displayed. The actual value displayed may not equal the temperature at different points of the shaker chamber due to many variables.

If you wish to have the actual value displayed on the shaker match a different point of the chamber, you must:

1. Calculate the temperature offset desired.
2. Create the temperature offset in the *CAL* screen.

Operation

New Brunswick™ Innova®40/40R Shaker
English (EN)

5.10.2 Calculating the temperature offset

In the *CAL* screen:

1. Allow the shaker enough time to equilibrate to setpoint temperature.
2. Record the displayed setpoint temperature (**temp1**).
3. Record the temperature inside the chamber (**temp2**). You may record the temperature inside a flask or at any point inside the temperature.
4. Use the formula: **temp2 - temp1 = °C offset**

5.10.3 Creating the temperature offset

In the *CAL* screen:

1. Calculate the temperature offset value to plug in (see *Calculating the temperature offset on p. 36*).
2. Turn the *Control knob* to select the °C *Offset* value (0.0 in figure).
3. Enter the °C *offset* desired.

5.10.4 Calibrating the shaking speed

The Innova 40/40R is calibrated at the factory. The speed does not need to be recalibrated until a major operating component (e.g. a drive belt) is changed. This should be done by a qualified service technician.

5.11 Programs screen

Use the *PROG* screen to program steps for the shaker. The resident software for the Innova 40/40R can store up to four programs, each having as many as 15 steps. Each step can be programmed in 1 min increments, for total periods of 0 hr 1 min – 99 hr 59 min.

To enter the programming mode, use the **Control knob** to select the *PROG* screen.

In the *PROG* screen you can:

- Run a program.
- Create a *New* program.
- *Edit* a program.
- Turn *Off* a program.

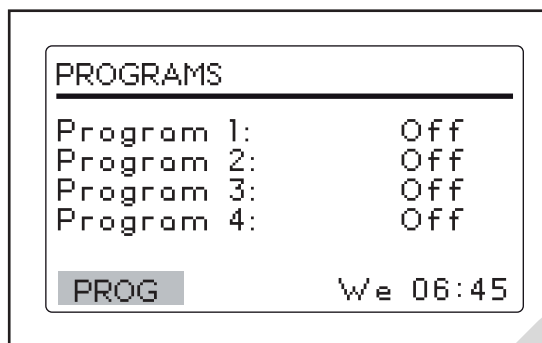
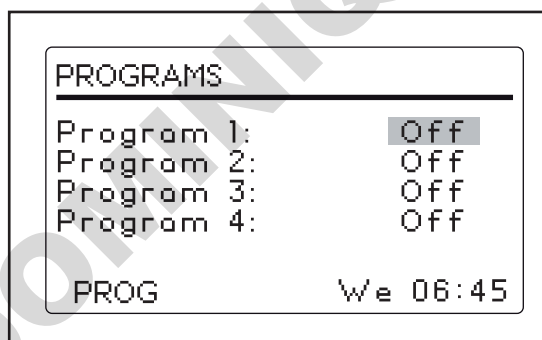


Fig. 5-8: Program screen

5.11.1 Create a program

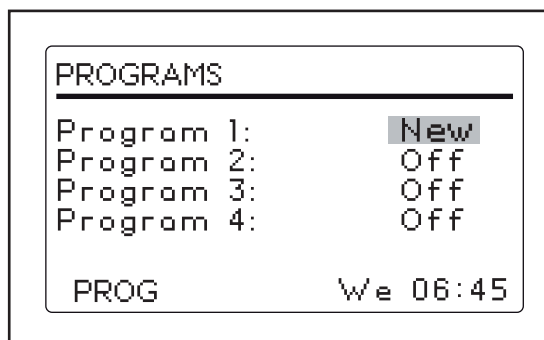
To write a new multi-step program in the *PROG* screen:



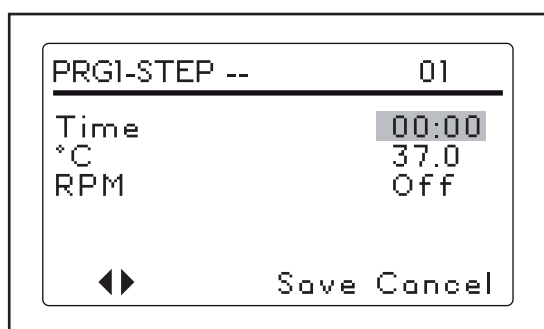
1. Use the **Control knob** to highlight the mode of *Program 1 (Off)* in figure).
2. Press the **Control knob**.
The selected field flashes.

Operation

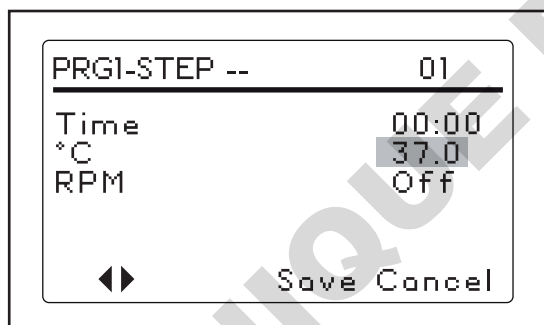
New Brunswick™ Innova®40/40R Shaker
English (EN)



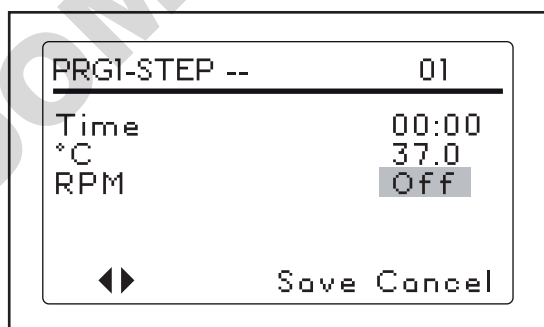
3. Turn the **Control knob** until the field says *New*.
4. Press the **Control knob** to select *New*.
The screen changes and you can start programming Step 1.



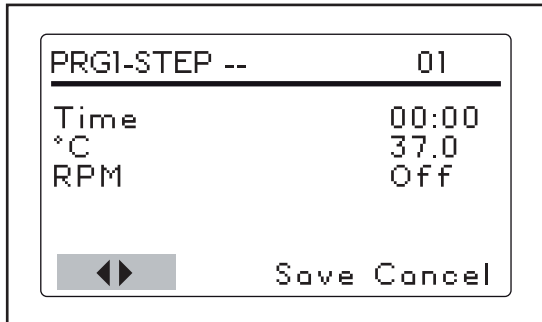
5. Turn the **Control knob** to highlight the *Time* value.
6. Press the **Control knob**.
The time flashes.
7. Turn the **Control knob** until the desired running duration for this step (from *00:01* – *99:59*)



8. Press the **Control knob** to save the setting.
9. Turn the **Control knob** to highlight the °C value.
10. Press the **Control knob**.
The °C value flashes.



11. Set the temperature desired and press the **Control knob** to save your setting.
12. Turn the **Control knob** to highlight the *RPM* value (*Off* in the sample figure).
13. Press the **Control knob**.
The *RPM* value flashes.
14. Turn the **Control knob** to select a speed.



15. Press the **Control knob** to save your selection.
16. To program a second step, use the **Control knob** to highlight the double arrows in the bottom-left corner of the screen.
17. Press the **Control knob**.
The double arrows flash.
18. Turn the **Control knob** 1 click clockwise to go to the Step 2 screen.
19. Press the **Control knob** to start programming Step 2 like you did with Step 1. You can program up to 15 Steps.

5.11.2 Save the program

To save a program:

1. Highlight *Save* and press the *Control knob*.
Save flashes.
2. Press the **Control knob** again to save the program.
The LCD displays *Process Running — Saving Profile* for a few seconds and then return to the main *PROG* screen.

5.11.3 Edit a program

Use the *Edit* mode to open a program you have already created and saved, in order to modify your settings following the same procedures.

5.11.4 Run and stop a program

Use the *Run* mode to turn a specific program on. Only one program can run at a time. When you change the mode to *Run*, the screen shows the *Run* icon.

To stop a program, change the program mode to *Off*.

5.12 Program the timer

By setting an *HRS* setpoint in the *DISP* or *SUMM* screen, the shaker may be set to automatically stop after a preset time period of 0 hr 1 min – 99 hr 59 min.

If the time is set to *0:00*, the shaker operates continuously until either the lid is opened or the **Start/Stop switch** is pushed.

Operation

New Brunswick™ Innova®40/40R Shaker
English (EN)

5.13 Power interruption

In the event of a mains/power failure, the Innova 40/40R is equipped with an automatic restart function. The shaker's non-volatile memory retains all stored information.

If the shaker was in operation prior to the power interruption, the shaker begins to operate at its last entered setpoints. The alarm *POWER* flashes on the display, indicating that a power interruption has occurred. Turn the **Control knob** in any direction to acknowledge the visual alarm. The flashing stops.

DOMINIQUE DUTSCHER SAS

6 Troubleshooting

6.1 Troubleshooting

Symptom	Cause	Solution
Shaker does not run.	<ul style="list-style-type: none"> • Mains/power cord is not plugged in. 	<ul style="list-style-type: none"> ▶ Plug in mains/power cord to working mains/power outlet.
	<ul style="list-style-type: none"> • Lid is ajar. 	<ul style="list-style-type: none"> ▶ Ensure lid is closed firmly.
	<ul style="list-style-type: none"> • Defective main board. • On/Off switch is broken. • Defective display board. • Jammed shaking mechanism. • Defective motor. • Drive belt out of alignment or worn. 	<ul style="list-style-type: none"> ▶ Call for service.
	<ul style="list-style-type: none"> • Shaking speed has been set to 0 by program running or by computer interface. 	<ul style="list-style-type: none"> ▶ Reset shaking speed.
	<ul style="list-style-type: none"> • Improperly installed fuse. 	<ul style="list-style-type: none"> ▶ Remove and reinstall fuse.
Shaker runs slowly and/or there is no speed indication.	<ul style="list-style-type: none"> • Improperly installed fuse. 	<ul style="list-style-type: none"> ▶ Remove and reinstall fuse.
	<ul style="list-style-type: none"> • Incorrect speed calibration. 	<ul style="list-style-type: none"> ▶ Recalibrate shaking speed.
	<ul style="list-style-type: none"> • Defective main board. • Defective motor. • Drive belt out of alignment or worn. 	<ul style="list-style-type: none"> ▶ Call for service.
Shaker does not run at set speed.	<ul style="list-style-type: none"> • Shaker is running in Program mode. • Shaker speed has been changed by computer interface. 	<ul style="list-style-type: none"> ▶ Check Run icon. ▶ Check shaker speed.
	<ul style="list-style-type: none"> • Shaker is overloaded and/or you are using baffled flasks. 	<ul style="list-style-type: none"> ▶ Remove some contents and balance load.
	<ul style="list-style-type: none"> • Defective motor. • Drive belt out of alignment or worn. 	<ul style="list-style-type: none"> ▶ Call for service.
	<ul style="list-style-type: none"> • Speed not calibrated correctly. 	<ul style="list-style-type: none"> ▶ Check speed calibration.
	<ul style="list-style-type: none"> • Load out of balance. 	<ul style="list-style-type: none"> ▶ Unload all contents and reload.
Excessive operating noise.	<ul style="list-style-type: none"> • Loose components in platform, subplatform, and/or drive assembly. 	<ul style="list-style-type: none"> ▶ Call for service.

Troubleshooting

New Brunswick™ Innova®40/40R Shaker
English (EN)

Symptom	Cause	Solution
Shaker does not reach set temperature.	<ul style="list-style-type: none"> • Shaker is running in Program mode. • Shaker speed has been changed by RS-232 command/ computer interface. 	<ul style="list-style-type: none"> ▶ Check Run icon. ▶ Check shaker speed.
	<ul style="list-style-type: none"> • Heater fuse blown. • Compressor fuse blown. 	▶ Replace fuse.
	<ul style="list-style-type: none"> • Compressor over-pressure switch activated. • Defective heater. • Defective refrigeration system. 	▶ Call for service.
	<ul style="list-style-type: none"> • Ambient temperature too high or too low. 	▶ Adjust the room temperature.
Incorrect temperature indication.	<ul style="list-style-type: none"> • Temperature Offset has been programmed. 	▶ Look for Offset icon in display.
	<ul style="list-style-type: none"> • Defective RTD assembly. • Defective main board. 	▶ Call for service.

7 Maintenance

7.1 Routine maintenance

No routine maintenance schedule is required for the Innova 40/40R Shaker.

Clean the shaker occasionally with a conventional household (non-abrasive) cleaner.

To ensure proper air flow in and around the shaker, vacuum or sweep the area around the shaker to remove dust and other debris.

7.2 Cleaning external and internal surfaces



WARNING! Personnel injury and equipment damage

- ▶ Always turn off the shaker and disconnect the mains/power cord from the mains/power supply before cleaning the shaker.



WARNING! Risk of equipment damage

- ▶ Do not use abrasive or corrosive compounds to clean the shaker.

1. Routinely clean the exterior of the shaker by wiping it over with a soft cloth, moistened with soapy water.
2. Rinse the soap from the cloth in clean water, and wipe the exterior surfaces again.

If there is biohazard contamination, see below.

7.3 Biohazard decontamination

**WARNING! Risk of potential harm to personnel**

- ▶ It is the responsibility of the user to carry out appropriate decontamination procedures if hazardous material is spilled on or inside the equipment. Before using any cleaning or decontamination method other than those suggested by the manufacturer, users should contact Eppendorf that the proposed method would not damage the equipment.

**WARNING! Risk of potential harm to personnel**


- ▶ As a routine precaution, wear protective gloves.
 - ▶ Be sure to adequately ventilate the work area as you disinfect, to avoid the formation of potentially explosive alcohol vapors.
-

Commercially available household bleach solutions, when diluted at a 1:10 ratio, are effective in routine decontamination of the instrument. The method for decontaminating a spill depends upon the nature of the spill.

1. Switch off the shaker. Unplug the shaker from the mains/power supply.
2. Spills involving fresh cultures or samples known to have low concentrations of biomass should be flooded with decontamination solution and soaked for 5 min before cleanup.
3. Spills involving samples with high concentrations of biomass, or involving organic matter, or occurring in areas warmer than room ambient temperature, should be exposed to decontamination solution for at least 1 h before cleanup.

8 Technical data

8.1 Specifications

 Use of baffled flasks significantly reduces maximum speed for any shaker.

These specifications assume a maximum load of 15.5 kg (34 lb), including platforms, clamps, glassware and contents.

8.1.1 Agitation

Speed	25 rpm – 500 rpm
Control accuracy	±1 rpm
Stroke	1.9 cm (3/4 in) or 2.5 cm (1 in)
Indication	Displayed in 1 rpm increments
Alarm signal with speed deviation	±5 rpm
Drive mechanism	Triple-eccentric counterbalanced drive with 9 permanently lubricated ball bearings. Driven by a solid-state brushless motor
Heaters	Low watt-density, resistance heaters with high-temperature safety thermostat cut-out.

The following table shows the maximum achievable speed depending on the load. The load example values are composed of flask clamps, flasks filled with water and other accessories.

Load (examples)	Achievable speed
4,5 kg (10 lb)	500 rpm
5,6 kg (12,3 lb)	500 rpm
6,9 kg (15,2 lb)	425 rpm
9,3 kg (20,4 lb)	400 rpm

8.1.2 Temperature system

40 temperature range	10 °C above ambient temperature to 80 °C
40R temperature range	15 °C below ambient temperature (minimum 4 °C) to 80 °C
Control accuracy	±0.1 °C at 37 °C
Indication	Displayed in 0.1 °C increments
Alarm signal with temperature deviation	±1 °C
Altitude limit	2000 m
Pollution Degree	2

Technical data

New Brunswick™ Innova®40/40R Shaker
English (EN)

8.1.3 Power supply

Mains/power supply	100 V \pm 10 %, 50 – 60 Hz 120 V \pm 10 %, 60 Hz 230 V \pm 10 %, 50 Hz	40: 800 VA 40R: 1500 VA
Overvoltage Category	II	

8.1.4 Ambient conditions

Ambience	Only for use indoors.
Ambient temperature	10 °C – 35 °C
Relative humidity	20 % – 80 %, non-condensing

8.1.5 Dimensions and weight

Dimensions	Width: 55.9 cm (22 in) Depth: 76.2 cm (30 in) Height: 61 cm (24 in) Lid open height: 102 cm (40 in)
Chamber dimensions	Width: 51.4 cm (20.3 in) Depth: 54.4 cm (21.5 in) Height: 35.6 cm (14 in)
Platform dimensions	Width: 46 cm (18 in) Depth: 46 cm (18 in) (Select universal or dedicated styles.)
Space requirements	Width: 68.6 cm (27 in) Depth: 83.2 cm (33 in) Height: 106.7 cm (42 in)
Weight	40 net weight: 60 kg (133 lb) 40R net weight: 79 kg (175 lb)

8.1.6 Alarms

There is a visible and audible warning indication when:

- Speed deviates more than \pm 1 rpm from setpoints.
- Temperature deviates more than \pm 1 °C from setpoints.
- When timer has expired.

Audible alarm can be muted.

8.1.7 Display

- 240 cm \times 128 cm backlit LCD

8.1.8 RS-232

- Remote control.
- Remote monitoring.
- Remote data logging.

8.1.9 Compliance and Certifications

UL 61010-1; UL 61010-2-010; UL 61010-2-011; UL 61010-2-051.

CAN/CSA C22.2 No. 61010-1-12; CAN/CSA C22.2 No. 61010-2-010;

CAN/CSA C22.2 No. 61010-2-011; CAN/CSA C22.2 No. 61010-2-051

8.1.10 CE Directives and Standards

See Declaration of Conformity:

8.2 Certifications

The Innova 40/40R has been tested to comply with UL and CAN/CSA electrical safety standards.

As attested in the CE Declaration of Conformity, the Innova 40/40R also conform to the appropriate CE standards.

Technical data

New Brunswick™ Innova®40/40R Shaker
English (EN)

DOMINIQUE DUTSCHER SAS

9 Ordering Information

9.1 Replacement parts

We recommend that you have on hand:

Tab. 9-1: Spare parts kit M1352-6000

Description	Quantity
V-Belt	1
Gas springs	2
Fuse, 8 A	4

9.2 Accessories

When ordering accessories, you may be asked to provide the model number and serial number of your shaker. This information is on the electrical specification plate, located on the rear panel of the unit.

9.2.1 Platforms

Description	Capacity	Part No.
Universal platform	(Tab. on p. 50)	M1250-9902
125 mL Erlenmeyer flask dedicated platform ¹	34	M1194-9904
250 mL Erlenmeyer flask dedicated platform ¹	25	M1194-9905
500 mL Erlenmeyer flask dedicated platform ¹	16	M1194-9906
1 L Erlenmeyer flask dedicated platform ¹	9	M1194-9907
2 L Erlenmeyer flask dedicated platform ¹	5	M1194-9908
2.8 L Fernbach flask dedicated platform ¹	4	M1233-9932
Utility carrier with cushioned crossbars	–	M1194-9909
Utility tray with non-skid rubber surface	–	M1194-9910
Sticky pad platform	–	M1250-9903

Clamps for universal platform are sold separately.

Ordering Information

New Brunswick™ Innova®40/40R Shaker
English (EN)

Tab. 9-2: Universal platform flask capacities

Flask Type	Capacity	Part No.
10 mL	109	ACE-10S
25 mL	64	M1190-9004
50 mL Erlenmeyer flasks	45	M1190-9000
125 mL Erlenmeyer flasks	21	M1190-9001
250 mL Erlenmeyer flasks	18	M1190-9002
500 mL Erlenmeyer flasks	14	M1190-9003
1 L Erlenmeyer flasks	8	ACE-1000S
2 L Erlenmeyer flasks	5	ACE-2000S
2.8 L Fernbach flasks	4	ACSB-2800S
3 L Erlenmeyer flasks	4	ACE-3000S

9.2.2 Replacement clamp hardware kits

Eppendorf flask clamps come complete with mounting screws. Additional screws are available separately in packs of 25 (S2116-3051P).

9.2.3 Test tube racks and other accessories

Tab. 9-3: Racks and Trays

Accessory Description	Part Number	Platform Capacity	
Adjustable angle test tube rack for tubes 8 mm – 11 mm diameter	80 tube capacity	M1289-0100	7
	60 tube capacity	M1289-0010	9
	48 tube capacity	M1289-0001	9
Adjustable angle test tube rack for tubes 12 mm – 15 mm diameter	60 tube capacity	M1289-0200	7
	44 tube capacity	M1289-0020	9
	34 tube capacity	M1289-0002	9
Adjustable angle test tube rack for tubes 15 mm – 18 mm diameter	42 tube capacity	M1289-0300	7
	31 tube capacity	M1289-0030	9
	24 tube capacity	M1289-0003	9
Adjustable angle test tube rack for tubes 18 mm – 21 mm diameter	30 tube capacity	M1289-0400	7
	23 tube capacity	M1289-0040	9
	18 tube capacity	M1289-0004	9
Adjustable angle test tube rack for tubes 22 mm – 26 mm diameter	22 tube capacity	M1289-0500	7
	16 tube capacity	M1289-0050	9
	13 tube capacity	M1289-0005	9
Adjustable angle test tube rack for tubes 26 mm – 30 mm diameter	20 tube capacity	M1289-0600	7
	16 tube capacity	M1289-0060	9
	12 tube capacity	M1289-0006	9
Microplate holder rack (stacked)	3 deep well or 9 standard	M1289-0700	16
Microplate holder rack (single layer)	5 deep well or standard	TTR-221	4
Angled test tube rack holder ¹ for user-supplied test tube racks that are 10 mm – 13 mm (4 in – 5 in) wide and up to 38 mm (15 in) long.	TTR-210	4	
Angled test tube rack spacer bar ¹ for use with TTR-210 to accommodate test tubes racks that are less than 13 mm (5 in) wide.	TTR-215	NA	

¹ Universal Platform Required

Ordering Information

New Brunswick™ Innova®40/40R Shaker
English (EN)

DOMINIQUE DUTSCHER SAS

10 Transport, storage and disposal

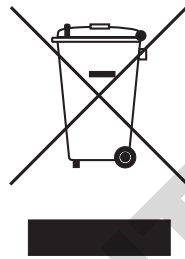
10.1 Disposal

In case the product is to be disposed of, the relevant legal regulations are to be observed.

Information on the disposal of electrical and electronic devices in the European Community:

Within the European Community, the disposal of electrical devices is regulated by national regulations based on EU Directive 2012/19/EU pertaining to waste electrical and electronic equipment (WEEE).

According to these regulations, any devices supplied after August 13, 2005, in the business-to-business sphere, to which this product is assigned, may no longer be disposed of in municipal or domestic waste. To document this, they have been marked with the following identification:



Because disposal regulations may differ from one country to another within the EU, please contact your supplier if necessary.

In Germany, this is mandatory from March 23, 2006. From this date, the manufacturer has to offer a suitable method of return for all devices supplied after August 13, 2005. For all devices supplied before August 13, 2005, the last user is responsible for the correct disposal.

Index

New Brunswick™ Innova®40/40R Shaker
English (EN)

Index**A**

Accessories.....	15, 49
Alarms	15, 15, 17, 17
Ambient humidity.....	19
Ambient temperature	19

B

Baud rate	35
Biohazard decontamination	44

C

Chamber temperature	45
Changing screens	27
Clamp	
Double girdle clamp.....	22
Clamp installation.....	22
Clamp screws	22
Cleaning	43
Create a program.....	37

D

Danger level	
CAUTION	7
DANGER.....	7
NOTICE	7
WARNING.....	7
Decontamination	44
Device overview	
Front view	13
Rear view	13
Display screen	29, 46
Disposal	53
Drip pan.....	16

F

Flask clamp installation	22
Flasks	15
Front panel.....	25

H

Heater	16
--------------	----

I

Icons	
Alarm on	26
Lid open.....	26, 26
Lock on	26
Program running.....	26

L

LCD	46
Lid	
Opening the lid.....	28
Location	19

M

Mains/power	
Connecting to the mains/power supply.....	23
Manual conventions.....	8
Memory	
Non-volatile memory.....	40

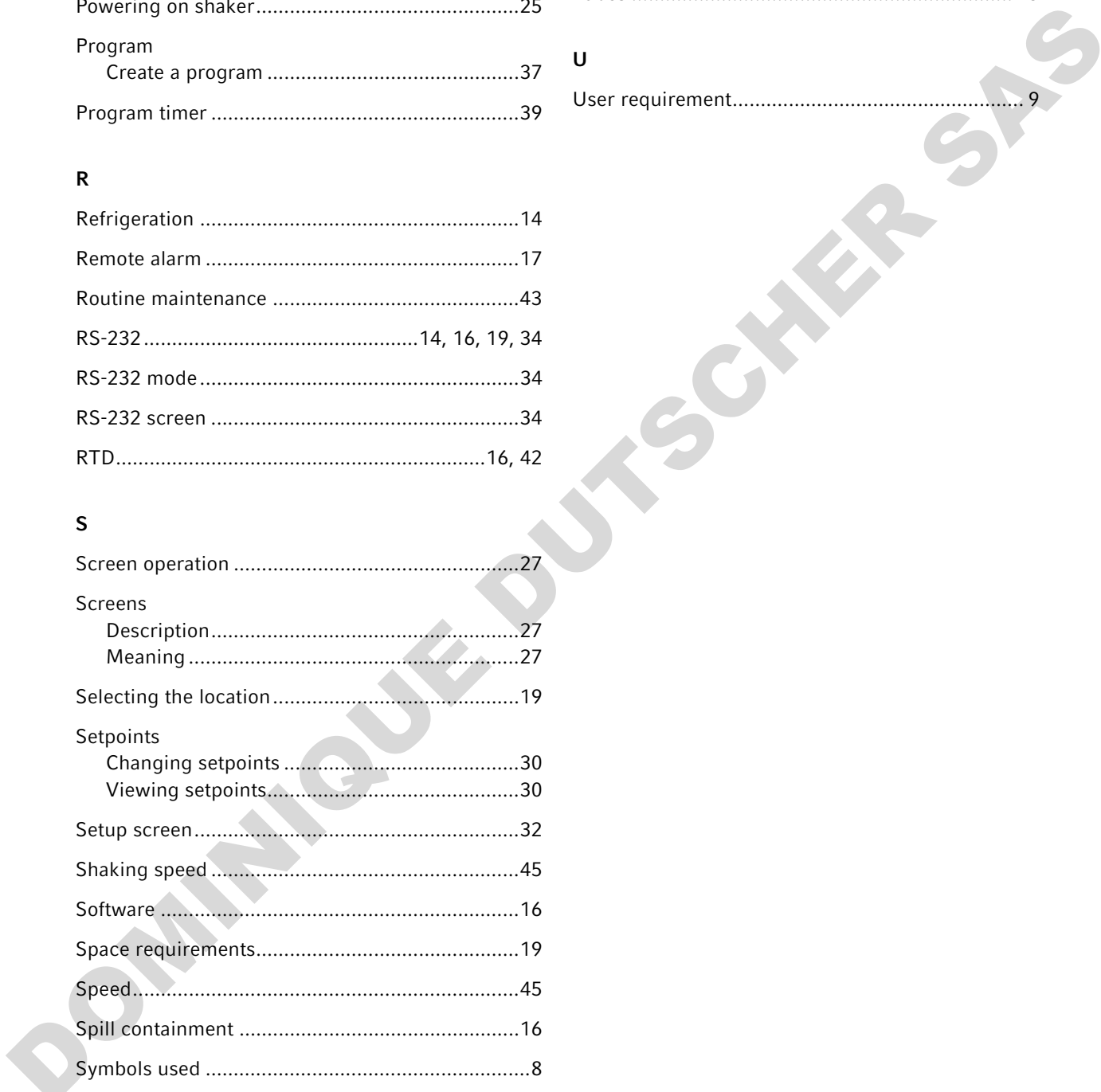
O

Operating controls	25
Orbit.....	14

P

Package list.....	14
Parameters	29
Parameter meanings	27
Parameter names.....	27
Platform	
Installation.....	20

Platforms	15
Power interruption	40
Powering on shaker	25
Program	
Create a program	37
Program timer	39
R	
Refrigeration	14
Remote alarm	17
Routine maintenance	43
RS-232	14, 16, 19, 34
RS-232 mode	34
RS-232 screen	34
RTD	16, 42
S	
Screen operation	27
Screens	
Description	27
Meaning	27
Selecting the location	19
Setpoints	
Changing setpoints	30
Viewing setpoints	30
Setup screen	32
Shaking speed	45
Software	16
Space requirements	19
Speed	45
Spill containment	16
Symbols used	8
T	
Temperature	45
Timed run	39
Timer	
Programming the timer	40
Tubes	15
U	
User requirement	9



DOMINIQUE DUTSCHER SAS

Declaration of Conformity

The product named below fulfills the requirements of directives and standards listed. In the case of unauthorized modifications to the product or an unintended use this declaration becomes invalid. This declaration of conformity is issued under the sole responsibility of the manufacturer.

Product name:

New Brunswick™ Innova® 40

including accessories

Product type:

Incubator Shaker

Relevant directives / standards:

2014/35/EU: EN 61010-1, EN 61010-2-010, EN 61010-2-051

2014/30/EU: EN 61326-1, EN 55011 (class A)

2011/65/EU: EN IEC 63000
(incl. (EU) 2015/863)

Further applied standards: IEC 61010-1, IEC 61010-2-010, IEC 61010-2-051

UL 61010-1, UL 61010-2-010, UL 61010-2-051

CAN/CSA C22.2 No. 61010-1-12, CSA C22.2 No. 61010-2-010,
CSA C22.2 No. 61010-2-051

IEC 61326-1, CISPR 11, FCC 47 CFR Part 15 (class A)

Hamburg, August 06, 2021



Dr. Wilhelm Plüster
Management Board



Dr. Marlene Jentzsch
Senior Vice President
Division Separation & Instrumentation

Your local distributor: www.eppendorf.com/contact
Eppendorf AG · Barkhausenweg 1 · 22339 Hamburg · Germany
eppendorf@eppendorf.com

ISO
9001
Certified

ISO 13485
Certified

ISO 14001
Certified

Eppendorf® and the Eppendorf Brand Design are registered trademarks of Eppendorf AG, Germany. New Brunswick™ is a trademark of Eppendorf AG.
Innova® is a registered trademark of Eppendorf Inc., USA.
All rights reserved, incl. graphics and images. Copyright ©2021 by Eppendorf AG.

Declaration of Conformity

The product named below fulfills the requirements of directives and standards listed. In the case of unauthorized modifications to the product or an unintended use this declaration becomes invalid. This declaration of conformity is issued under the sole responsibility of the manufacturer.

Product name:

New Brunswick™ Innova® 40R

including accessories

Product type:

Incubator refrigerated Shaker

Relevant directives / standards:

2014/35/EU: EN 61010-1, EN 61010-2-010, EN 61010-2-011, EN 61010-2-051

2014/30/EU: EN 61326-1, EN 55011 (class A)

2011/65/EU: EN IEC 63000
(incl. (EU) 2015/863)

Further applied standards: IEC 61010-1, IEC 61010-2-010, IEC 61010-2-011, IEC 61010-2-051
UL 61010-1, UL 61010-2-010, UL 61010-2-011, UL 61010-2-051
CAN/CSA C22.2 No. 61010-1-12, CSA C22.2 No. 61010-2-010,
CSA C22.2 No. 61010-2-011, CSA C22.2 No. 61010-2-051
IEC 61326-1, CISPR 11, FCC 47 CFR Part 15 (class A)

Hamburg, August 06, 2021



Dr. Wilhelm Plüster
Management Board



Dr. Marlene Jentzsch
Senior Vice President
Division Separation & Instrumentation

Your local distributor: www.eppendorf.com/contact
Eppendorf AG · Barkhausenweg 1 · 22339 Hamburg · Germany
eppendorf@eppendorf.com

ISO
9001
Certified

ISO 13485
Certified

ISO 14001
Certified

Eppendorf® and the Eppendorf Brand Design are registered trademarks of Eppendorf AG, Germany. New Brunswick™ is a trademark of Eppendorf AG.
Innova® is a registered trademark of Eppendorf Inc., USA.
All rights reserved, incl. graphics and images. Copyright ©2021 by Eppendorf AG.

DOMINIQUE DUTSCHER SAS

Evaluate Your Manual

Give us your feedback.
www.eppendorf.com/manualfeedback

DOMINIQUE DUTSCHER SAS