



# ULUF 125

**THE ULUF 125 WILL ADD A NEW DIMENSION TO YOUR LABORATORY.**

The compact space-saving design and low heat and noise level makes it a perfect storage solution for your laboratory.



SINGLE  
COMPRESSOR  
SYSTEM



DIRECT  
COOLING



FILTERLESS  
CONSTRUCTION

## COOLING TECHNOLOGY

The small size is achieved by utilizing Arctiko's special single compressor technology.

The single compressor technology is specially designed to reduce the number of mechanical components that generates unnecessary heat and noise. It comes with the same advantages as regular sized -86°C from Arctiko and is best in class in cooling performance.

## FILTERLESS CONSTRUCTION

Our filter less construction makes cleaning unnecessary. The evaporator coils are spaced so far apart that dust will not be trapped and obstruct the airflow.

With our compressors located on the top, the dust intake is minimal this eliminating the need for filters entirely, saving you maintenance time and cost.

## CUSTOMIZED SOLUTIONS

Even in this size Arctiko can provide a wide range of accessories for customization of the unit, though it is not required to function.

With an optional CO<sub>2</sub> back-up system will keep your samples cold as long as there is CO<sub>2</sub> available in the system – eliminating the dangers of an unstable power grid or simply bad weather.

## MAIN DIMENSION FOR ULUF 125

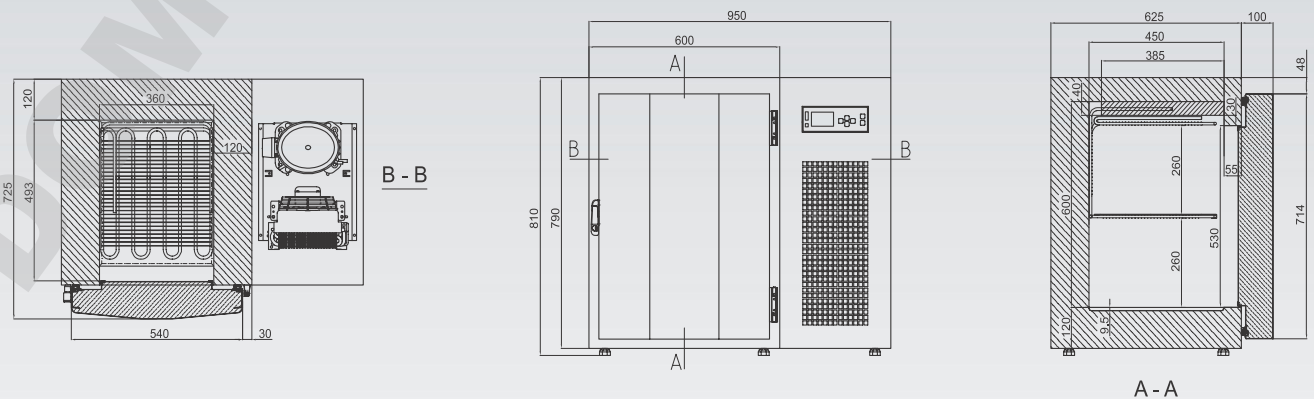



User friendly G214 controller standard in the ULUF 125. Includes different alarms as; visual, acoustic, open door and more.

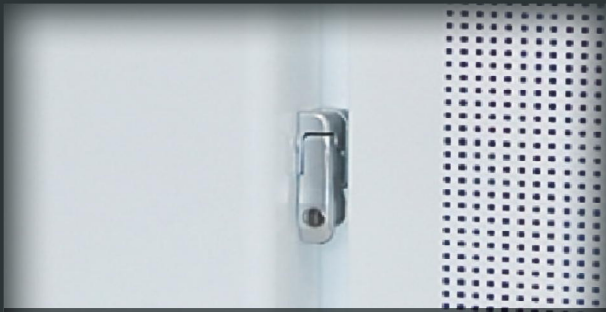

Key lock is standard feature in our ULUF 125. Placed on side of door for optimal security for your samples.



Insulated inner door for better recovery time after door openings and optimal temperature stability.

## OPTIONAL ACCESSORIES

- Modbus adapter for G214 controller
- Temperature chart recorder
- CO2 back-up system
- GSM alarm module
- Voltage converter
- Voltage stabilizer
- Racks & boxes
- Cryo gloves

## MAIN SPECIFICATIONS

Item code	DAI 1417
Temperature range (°C)	-40 / -86
Max. ambient temperature (°C)	25
Capacity (L)	94
Exterior dimensions WxDxH (mm)	950x725x810
Interior dimensions WxDxH (mm)	360x493x530
Weight (KG)	98
Insulation (mm)	120
Cooling technology	single system / static
Controller model / probe type	G214 / PT1000

## POWER

Power supply (V)	230
Frequency (Hz)	50/60
Power consumption (kWh/24H)	7,0
AMP (A)	3,3
Power (Watt)	484
Horse power (HP)	5/8

## ALARM FUNCTIONS

Alarm display as text - not codes	yes
Visual / acoustic alarm	yes / yes
Power failure alarm	yes
Adjustable high / low temperature alarm	yes / yes
Open door alarm	yes
Probe failure alarm	yes
Low battery alarm	yes
Compressor failure alarm	yes
Battery backup for alarms (approx. hrs.)	72

## DATA LOGGING & EXTERNAL CONNECTION

Voltage free contact for remote alarm (e.g. GSM module)	yes
Electronic data logger	yes
RS 485 port	yes
USB port for software update & data download	yes
Temperature chart recorder	optional

## DISPLAY FEATURES

Display type	4,3" with touch buttons
Number of optional reference probes	2
Password protection for turning unit on / off	yes
Temperature graph on display	yes

## OTHER FEATURES

Automatic defrost	no
Antifreeze function	no
Vacuum release port	no
Access port for external probe etc. (int. diameter mm)	12
Light	no
Lock with key	yes
Castors (total pcs) / castors with brake (pcs)	2 rollers / 0
Fixed feet (pcs) / levelling feet (pcs)	0 / 2
Sub lids or inner doors (pcs)	2
Reversible door(s)	no
Fixed shelves (pcs) / adjustable shelves (pcs)	1 / 0
Max. no. shelves (pcs) / recommended max. no. shelves (pcs)	1 / 1
Max. load per shelf (kg)	25
Total capacity of 50 mm boxes 9x9 dividers (pcs)	48
Total capacity of 75 mm boxes 9x9 dividers (pcs)	36
Total capacity of 96 mm boxes 9x9 dividers (pcs)	32

## REFRIGERATION & CABINET

Number of compressors	1
Refrigerant	EP88
Interior cabinet material	stainless steel
Exterior cabinet material	electrogalvanized steel
Colour (exterior cabinet)	white
Foam type	polyurethane
VIP vacuum insulated panels	no

## SHIPPING

Shipping weight (KG)	129
Shipping dimensions WxDxH (cm)	103x81x103
Shipping volume (m <sup>3</sup> )	0,86