

Register your instrument!  
[www.eppendorf.com/myeppendorf](http://www.eppendorf.com/myeppendorf)



# Centrifuge 5804/5804 R/5810/5810 R

Operating manual  
Manuel d'utilisation

Copyright © 2016 Eppendorf AG, Germany. All rights reserved, including graphics and images. No part of this publication may be reproduced without the prior permission of the copyright owner.

Eppendorf® and the Eppendorf logo are registered trademarks of Eppendorf AG, Germany.

CombiSlide is a registered trademark of Eppendorf AG, Germany.

Centriplus is a registered trademark of Millipore Corporation, USA.

Corning is a registered trademark of Corning Inc., USA.

Microtainer is a registered trademark of Becton Dickinson, USA.

Registered trademarks and protected trademarks are not marked in all cases with ® or ™ in this manual.

U.S. Design Patents are listed on [www.eppendorf.com/ip](http://www.eppendorf.com/ip)

Operating manual . . . . .	3
Manuel d'utilisation . . . . .	111
Annex . . . . .	155
Certificates . . . . .	158

## Table of contents

<b>1</b>	<b>Operating instructions</b>	<b>7</b>
1.1	Using this manual	7
1.2	Danger symbols and danger levels	7
1.2.1	Danger symbols	7
1.2.2	Danger levels	7
1.3	Symbols used	7
1.4	Abbreviations used	8
<b>2</b>	<b>Safety</b>	<b>9</b>
2.1	Intended use	9
2.2	User profile	9
2.3	Application limits	9
2.3.1	Declaration concerning the ATEX Directive (2014/34/EU)	9
2.3.2	Maximum service life for accessories	10
2.4	Information on product liability	11
2.5	Warnings for intended use	12
2.5.1	Personal injury or damage to the equipment	12
2.5.2	Incorrect handling of the centrifuge	14
2.5.3	Incorrect handling of the rotors	14
2.5.4	Extreme strain on the centrifuging tubes	16
2.5.5	Aerosol-tight centrifugation	17
2.6	Safety instructions on the device	18
<b>3</b>	<b>Product description</b>	<b>19</b>
3.1	Product overview	19
3.2	Delivery package	19
3.3	Features	20
<b>4</b>	<b>Installation</b>	<b>21</b>
4.1	Selecting the location	21
4.2	Preparing installation	21
4.3	Installing the instrument	22
<b>5</b>	<b>Operation</b>	<b>25</b>
5.1	Operating controls	25
5.2	Preparing for centrifugation	27
5.2.1	Switching on the centrifuge	27
5.2.2	Inserting the rotor	27
5.2.3	Automatic rotor detection	28
5.2.4	Loading the rotor	29
5.2.5	Closing the centrifuge lid	33
5.3	Cooling (only 5804 R/5810 R)	34
5.3.1	Temperature adjustment	34
5.3.2	Temperature display	34
5.3.3	Temperature monitoring	34
5.3.4	FastTemp	34
5.3.5	Continuous cooling	35

**Table of contents**

Centrifuge 5804/5804 R/5810/5810 R  
English (EN)

5.4	Centrifuging .....	36
5.4.1	Centrifugation with time setting .....	36
5.4.2	Centrifuging in continuous operation .....	37
5.4.3	Short spin centrifugation .....	38
5.4.4	Removing the rotor .....	39
5.4.5	Standby mode .....	39
<b>6</b>	<b>Operating controls and function .....</b>	<b>41</b>
6.1	Setting the radius .....	41
6.2	Setting the acceleration and braking times .....	41
6.3	Setting the start of run time (At set rpm) .....	42
6.4	Saving the program .....	42
6.5	Loading the program .....	43
6.6	Deleting the program .....	43
6.7	Special functions .....	44
6.7.1	Display operating hours .....	44
6.7.2	Switching on/off the warning signal .....	44
6.7.3	Exiting the service functions .....	44
<b>7</b>	<b>Maintenance .....</b>	<b>45</b>
7.1	Maintenance .....	45
7.2	Preparing cleaning/disinfection .....	45
7.3	Cleaning/disinfection .....	46
7.3.1	Cleaning and disinfecting the device .....	47
7.3.2	Cleaning and disinfecting the rotor .....	48
7.4	Additional care instructions for refrigerated centrifuges .....	48
7.5	Breakage of glass .....	49
7.6	Decontamination before shipment .....	49
<b>8</b>	<b>Troubleshooting .....</b>	<b>51</b>
8.1	Resetting the excess current switch .....	51
8.2	General errors .....	51
8.3	Error messages .....	52
8.4	Emergency release .....	54
<b>9</b>	<b>Transport, storage and disposal .....</b>	<b>55</b>
9.1	Transport .....	55
9.2	Storage .....	55
9.3	Disposal .....	56
<b>10</b>	<b>Technical data .....</b>	<b>57</b>
10.1	Power supply .....	57
10.2	Ambient conditions .....	57
10.3	Weight/dimensions .....	58
10.4	Application parameters .....	59
10.5	Rotors .....	61
10.5.1	Rotor A-4-81 (only 5810/5810 R) .....	61
10.5.2	Rotor A-4-62 and A-4-62-MTP (only 5810/5810 R) .....	66
10.5.3	Rotor A-4-44 .....	70
10.5.4	Rotor A-2-DWP-AT (only 5810/5810 R) .....	73



10.5.5	A-2-DWP rotor	75
10.5.6	Rotor FA-45-6-30	77
10.5.7	Rotor F-34-6-38	79
10.5.8	Rotor FA-45-30-11 and F-45-30-11	81
10.5.9	Rotor F-45-48-PCR	82
10.5.10	Rotor T-60-11	82
10.5.11	Rotor S-4-104 (only 5810/5810 R)	83
10.5.12	Rotor S-4-72	90
10.5.13	Rotor F-35-48-17	92
10.5.14	Rotor FA-45-48-11	93
10.5.15	Rotor FA-45-20-17	94
<b>11</b>	<b>Ordering information</b>	<b>95</b>
11.1	Centrifuge 5804/5804 R	95
11.2	Centrifuge 5810/5810 R	95
11.3	Rotors	96
11.3.1	Rotor A-4-81 (only 5810/5810 R)	96
11.3.2	Rotor A-4-62 and A-4-62-MTP (only 5810/5810 R)	98
11.3.3	Rotor A-4-44	99
11.3.4	Rotor A-2-DWP-AT (only 5810/5810 R)	100
11.3.5	Rotor A-2-DWP	101
11.3.6	Rotor FA-45-6-30	102
11.3.7	Rotor F-34-6-38	103
11.3.8	Rotor FA-45-30-11 and rotor F-45-30-11	104
11.3.9	Rotor F-45-48-PCR	104
11.3.10	Rotor T-60-11	104
11.3.11	Rotor S-4-104	105
11.3.12	Rotor S-4-72	107
11.3.13	Rotor F-35-48-17	107
11.3.14	Rotor FA-45-48-11	108
11.3.15	Rotor FA-45-20-17	108
11.4	Accessories	109
11.4.1	Mains/power cord for Centrifuge 5804 and Centrifuge 5810	109
11.4.2	Mains/power cord for Centrifuge 5804 R and Centrifuge 5810 R	109

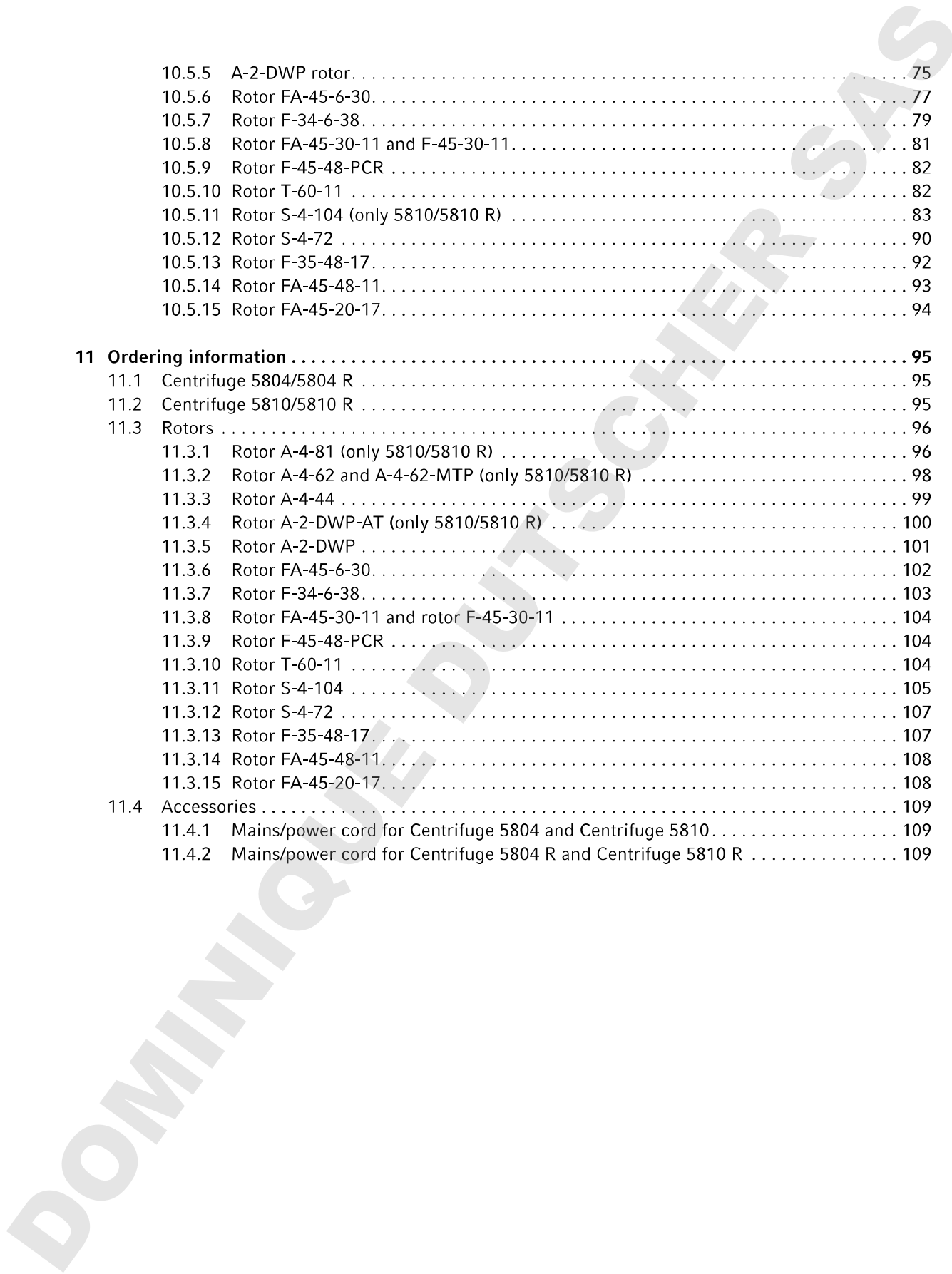

DOMINIQUE DUTSCHER SAS

## 1 Operating instructions







### 1.1 Using this manual

- ▶ Read this operating manual completely before using the device for the first time. Also observe the instructions for use of the accessories.
- ▶ This operating manual is part of the product. Thus, it must always be easily accessible.
- ▶ Enclose this operating manual when transferring the device to third parties.
- ▶ You will find the current version of the operating manual for all available languages on our website under [www.eppendorf.com/manuals](http://www.eppendorf.com/manuals).

### 1.2 Danger symbols and danger levels

#### 1.2.1 Danger symbols

The safety instructions in this manual appear with the following danger symbols and danger levels:

	Biohazard		Explosive substances
	Electric shock		Risk of crushing
	Hazard point		Material damage

#### 1.2.2 Danger levels

<b>DANGER</b>	<i>Will</i> lead to severe injuries or death.
<b>WARNING</b>	<i>May</i> lead to severe injuries or death.
<b>CAUTION</b>	May lead to light to moderate injuries.
<b>NOTICE</b>	May lead to material damage.

### 1.3 Symbols used

Depiction	Meaning
1. 2.	Actions in the specified order
▶	Actions without a specified order
•	List
Text	Display text or software text
	Additional information

## 1.4 Abbreviations used

**MTP**

Microplate

**PCR**

Polymerase chain reaction

**rcf**Relative centrifugal force:  $g$ -force in  $m/s^2$ **rpm**

Revolutions per minute

**UV**

Ultraviolet radiation

DOMINIQUE DUTSCHER SAS

## 2 Safety

### 2.1 Intended use

The Centrifuge 5804/5804 R/5810/5810 R is designed for separating liquid substance mixtures with different densities, in particular, for processing and analyzing samples from the human body in in-vitro diagnostic applications to ensure that the in-vitro diagnostic device can be used according to its intended purpose. This centrifuge including components is an in-vitro diagnostic device according to Directive 98/79/EC of the European Parliament and the Council dated October 27, 1998.

Eppendorf centrifuges are exclusively intended for indoor use by trained specialists.

### 2.2 User profile

The device and accessories may only be operated by trained and skilled personnel.

Before using the device, read the operating manual carefully and familiarize yourself with the device's mode of operation.

### 2.3 Application limits

#### 2.3.1 Declaration concerning the ATEX Directive (2014/34/EU)



**DANGER! Risk of explosion.**

- ▶ Do not operate the device in areas where work is completed with explosive substances.
  - ▶ Do not use this device to process any explosive or highly reactive substances.
  - ▶ Do not use this device to process any substances which could create an explosive atmosphere.
- 

Due to its current design and the ambient conditions within the device, the Centrifuge 5804/5804 R/5810/5810 R is not suited for use in a potentially explosive atmosphere.

The device must only be used in a safe environment, such as the open environment of a ventilated laboratory or under a fume hood. The use of substances which could create a potentially explosive atmosphere is not permitted. The final decision on the risks associated with the use of these types of substances is the responsibility of the user.

### 2.3.2 Maximum service life for accessories



**WARNING! Risk of injury from chemically or mechanically damaged accessories.**

Even minor scratches and cracks can lead to severe internal material damage.

- ▶ Protect all accessory parts from mechanical damage.
- ▶ Inspect the accessories for damage before each use. Replace any damaged accessories.
- ▶ Do not use any rotors, rotor lids, buckets or caps showing signs of corrosion or mechanical damage (e.g., deformations).
- ▶ Do not use any accessories which have exceeded their maximum service life.
- ▶ When inserting the buckets and rotors, ensure that they do not become scratched.



**CAUTION! Risk of injury due to chemically damaged rotor lids or caps.**

Transparent rotor lids or caps made from PC, PP or PEI may lose their strength under the impact of organic solvents (e.g., phenol, chloroform).

- ▶ If rotor lids or caps have come into contact with organic solvents, they should be cleaned immediately.
- ▶ Check the rotor lids and caps regularly for any signs of damage and cracks.
- ▶ Replace any rotor lids or caps which show cracks or milky stains immediately.

The rotors listed below, and the corresponding buckets and rotor lids, have a maximum service life of the number of years or cycles listed in the table (whichever comes first), starting with initial setup.

Rotor	Maximum service life from initial setup onward	
A-2-DWP-AT	100,000 cycles	7 years
A-2-DWP	34,000 cycles	7 years
A-4-44	34,000 cycles	7 years
A-4-62	40,000 cycles	7 years
A-4-81	100,000 cycles	7 years
F-34-6-38	75,000 cycles	7 years
FA-45-6-30	100,000 cycles	7 years
FA-45-48-11	100,000 cycles	7 years
FA-45-20-17	100,000 cycles	7 years
F-35-48-17	100,000 cycles	7 years
S-4-72	100,000 cycles	7 years
S-4-104	100,000 cycles	7 years
T-60-11	n. a.	7 years

Accessories	Maximum service life from initial setup onward	
Aerosol-tight rotor lid, without replaceable seals	50 autoclaving cycles	–
QuickLock rotor lid		3 years
Seals of the QuickLock rotor lids	50 autoclaving cycles	–
Rotor lid and caps made of polycarbonate (PC), polypropylene (PP) or polyetherimide (PEI)	50 autoclaving cycles	3 years
Adapter	–	1 year

For all other rotors and rotor lids of this centrifuge there is no service life limit as long as the following prerequisites are met:

- Proper use
- Recommended maintenance
- Undamaged condition

The date of manufacture is stamped on rotors and buckets in the format *03/15* or *03/2015* (= March 2015). On the inside of the plastic rotor lid the date of manufacture is stamped in the form of a clock ⌚.

To ensure aerosol tightness, the following applies:

- Replace aerosol-tight rotor lids and caps after 50 autoclaving cycles.
- Replace the seal of QuickLock rotor lids after 50 autoclaving cycles.

## 2.4 Information on product liability

In the following cases, the designated protection of the device may be compromised. Liability for any resulting property damage or personal injury is then transferred to the operator:

- The device is not used in accordance with the operating manual.
- The device is used outside of its intended use.
- The device is used with accessories or consumables which are not recommended by Eppendorf.
- The device is maintained or repaired by people not authorized by Eppendorf.
- The user makes unauthorized changes to the device.

## 2.5 Warnings for intended use

### 2.5.1 Personal injury or damage to the equipment

---



**WARNING! Electric shock due to damage to the device or mains cable.**

- ▶ Only switch on the device if the device and mains cable are undamaged.
- ▶ Only use devices that have been properly installed or repaired.
- ▶ In case of danger, disconnect the device from the mains supply. Disconnect the mains/power plug from the device or the earth/grounded socket. Use the designated isolating device (e.g., emergency switch in the lab).



**WARNING! Lethal voltages inside the device.**

Touching parts which are under high voltage may cause an electric shock. An electric shock injures the heart and causes respiratory paralysis.

- ▶ Ensure that the housing is closed and undamaged.
- ▶ Do not remove the housing.
- ▶ Ensure that no liquid can penetrate into the device.

Only authorized service staff may open the device.



**WARNING! Risk from incorrect supply voltage.**

- ▶ Only connect the device to voltage sources which correspond to the electrical requirements on the name plate.
- ▶ Only use sockets with a protective earth (PE) conductor and suitable mains/power cord.



**WARNING! Damage to health due to infectious liquids and pathogenic germs.**

- ▶ When handling infectious liquids and pathogenic germs, observe the national regulations, the biological security level of your laboratory, the Material Safety Data Sheets, and the manufacturer's application notes.
- ▶ Use aerosol-tight sealing systems for the centrifugation of these substances.
- ▶ When working with pathogenic germs belonging to a higher risk group, more than one aerosol-tight bioseal must be used.
- ▶ Wear your personal protective equipment.
- ▶ For comprehensive regulations about handling germs or biological material of risk group II or higher, please refer to the "Laboratory Biosafety Manual" (source: World Health Organization, Laboratory Biosafety Manual, in its respectively current valid version).



**WARNING! Risk of injury when opening or closing the centrifuge lid.**

There is a risk of crushing your fingers when opening or closing the centrifuge lid.

- ▶ When opening or closing the centrifuge lid, do not reach between the lid and device or into the latching mechanism of the lid.
- ▶ Always open the centrifuge lid completely to prevent it from falling.





**WARNING! Risk of injury due to defective gas spring(s).**

A defective gas spring is an insufficient support for the centrifuge lid. There is a risk of crushing fingers or limbs.

- ▶ Make sure that the centrifuge lid can be opened completely and that it will remain in this position.
- ▶ Regularly check all gas springs for their proper function.
- ▶ Have defective gas springs replaced immediately.
- ▶ Have gas springs replaced by a service technician every 2 years.



**WARNING! Risk of injury from chemically or mechanically damaged accessories.**

Even minor scratches and cracks can lead to severe internal material damage.

- ▶ Protect all accessory parts from mechanical damage.
- ▶ Inspect the accessories for damage before each use. Replace any damaged accessories.
- ▶ Do not use any rotors, rotor lids, buckets or caps showing signs of corrosion or mechanical damage (e.g., deformations).
- ▶ Do not use any accessories which have exceeded their maximum service life.
- ▶ When inserting the buckets and rotors, ensure that they do not become scratched.



**CAUTION! Poor safety due to incorrect accessories and spare parts.**

The use of accessories and spare parts other than those recommended by Eppendorf may impair the safety, functioning and precision of the device. Eppendorf cannot be held liable or accept any liability for damage resulting from the use of incorrect or non-recommended accessories and spare parts, or from the improper use of such equipment.

- ▶ Only use accessories and original spare parts recommended by Eppendorf.



**NOTICE! Damage to device due to spilled liquids.**

1. Switch off the device.
2. Disconnect the device from the mains/power supply.
3. Carefully clean the device and the accessories in accordance with the cleaning and disinfection instructions in the operating manual.
4. If a different cleaning and disinfecting method is to be used, contact Eppendorf AG to ensure that the intended method will not damage the device.



**NOTICE! Damage to electronic components due to condensation.**

Condensate can form in the device after it has been moved from a cool environment to a warmer environment.

- ▶ After installing the device, wait for at least 4 h. Only then connect the device to the mains/power line.

**NOTICE! Buckets swinging out in the wrong direction.**

If the wrong adapters are used for 500 mL corning vessels, it might happen that the buckets of the swing-bucket rotor swing out in the wrong direction. This can lead to sample loss or damage of the centrifuge.

- ▶ Therefore, only use the Eppendorf adapters for 500 mL corning vessels intended for this purpose.

## 2.5.2 Incorrect handling of the centrifuge

**NOTICE! Damage from knocking against or moving the device during operation.**

If the rotor bangs against the rotor chamber wall, it will cause considerable damage to the device and rotor.

- ▶ Do not move or knock against the device during operation.

## 2.5.3 Incorrect handling of the rotors

**WARNING! Risk of injury from improperly attached rotors and rotor lids.**

- ▶ Only centrifuge with the rotor and rotor lid firmly tightened.
- ▶ If there are any unusual noises when the centrifuge is started up, the rotor or rotor lid may not be properly attached. Immediately press the **start/stop** key to stop centrifuging.

**CAUTION! Risk of injury due to asymmetric loading of the rotor.**

- ▶ Load rotors symmetrically with identical tubes or plates and buckets.
- ▶ Always load all positions of a swing-bucket rotor with buckets.
- ▶ Only load adapters with suitable tubes or plates.
- ▶ Always use tubes or plates of the same type (weight, material/density and volume).
- ▶ Check that loading is symmetrical by balancing the adapters and tubes or plates used with scales.

**CAUTION! Risk of injury from overloaded rotor.**

The centrifuge is designed for the centrifugation of material with a maximum density of 1.2 g/mL at maximum speed and filling volume and/or load.

- ▶ Do not exceed the maximum load of the rotor.



**CAUTION! Risk of injury due to chemically damaged rotor lids or caps.**

Transparent rotor lids or caps made from PC, PP or PEI may lose their strength under the impact of organic solvents (e.g., phenol, chloroform).

- ▶ If rotor lids or caps have come into contact with organic solvents, they should be cleaned immediately.
- ▶ Check the rotor lids and caps regularly for any signs of damage and cracks.
- ▶ Replace any rotor lids or caps which show cracks or milky stains immediately.



**NOTICE! Damage to rotors from aggressive chemicals.**

Rotors are high-quality components which withstand extreme stresses. This stability can be impaired by aggressive chemicals.

- ▶ Avoid the use of aggressive chemicals, including strong and weak alkalis, strong acids, solutions with mercury, copper and other heavy metal ions, halogenated hydrocarbons, concentrated saline solutions and phenol.
- ▶ If the rotor is contaminated by aggressive chemicals, clean it immediately using a neutral cleaning agent. This applies to the rotor bores in particular.
- ▶ Due to the manufacturing process, color variations may occur on rotors marked "coated". These color variations do not affect service life or resistance to chemicals.



**NOTICE! If handled incorrectly, the rotor may fall.**

The swing-bucket rotor may fall if the buckets are used as handles.

- ▶ Remove the buckets before inserting and/or removing a swing-bucket rotor.
- ▶ Always use both hands to carry the rotor cross.



**NOTICE! If handled incorrectly, the rotor may fall.**

- ▶ Always pick up the rotor F-35-48-17 with both hands.
- ▶ In order to hold the rotor safely, you may possibly have to remove 3 to 4 sleeves from the opposite outer row.

#### 2.5.4 Extreme strain on the centrifuging tubes

---



**CAUTION! Risk of injury from overloaded tubes.**

- ▶ Note the loading limits specified by the tube manufacturer.
  - ▶ Only use tubes which are approved by the manufacturer for the required  $g$ -force (rcf).
- 



**NOTICE! Risk from damaged tubes.**

Damaged tubes must not be used, as this could cause further damage to the device and the accessories and loss of the samples.

- ▶ Before use, visually check all of the tubes for damage.



**NOTICE! Risk from open tube lids.**

Open tube lids can break off during centrifugation and damage both the rotor and the centrifuge.

- ▶ Carefully seal all tube lids before centrifuging.



**NOTICE! Hazard to plastic tubes from organic solvents.**

The density of plastic tubes is reduced when organic solvents (e.g., phenol, chloroform) are used, i.e. the tubes could become damaged.

- ▶ Note the manufacturer's information on the chemical resistance of the tubes.



**NOTICE! Micro test tubes heat up.**

In uncooled centrifuges, the temperature in the rotor chamber, rotor and sample can increase to above 40 °C, depending on the run time,  $g$ -force (rcf)/speed and ambient temperature.

- ▶ Please note that this will reduce the centrifugation stability of the micro test tubes.
  - ▶ Please note the temperature resistance of the samples.
-

## 2.5.5 Aerosol-tight centrifugation

---



**WARNING! Risk to health due to limited aerosol tightness with incorrect rotor/rotor lid combination.**

Aerosol-tight centrifugation is guaranteed only if the rotors and rotor lids intended for this purpose are used. The designation of aerosol-tight fixed-angle rotors always starts with **FA**. The aerosol-tight rotors and rotor lids of this centrifuge are additionally marked with a red ring on the rotor and a red rotor lid screw.

Aerosol-tight swing-bucket rotors are marked **AT** (aerosol-tight).

- ▶ For aerosol-tight centrifugation, always simultaneously use rotors and rotor lids which are marked as aerosol-tight in the centrifuge intended for the corresponding purpose. The details specifying in which centrifuge you may use the aerosol-tight rotors and rotor lids can be found on the rotor and, beginning from production date of October 2003, on the upper side of the rotor lid.
- ▶ Only use aerosol-tight rotor lids in combination with rotors which are marked on the rotor lid.
- ▶ Only use aerosol-tight buckets with the corresponding caps.



**WARNING! Damage to health due to limited aerosol tightness in the event of incorrect use.**





Autoclaving, mechanical stresses and contamination by chemicals or other aggressive solvents can impair the aerosol tightness of the rotors and rotor lids.

- ▶ Check the integrity of the seals of the aerosol-tight rotor lids or caps before each use.
  - ▶ Only use aerosol-tight rotor lids or caps if the seals are undamaged and clean.
  - ▶ Apply a thin layer of pivot grease (order no. Int. 5810 350.050, North America 022634330) to the threads of the rotor lid screw after each proper autoclaving process (121 °C, 20 min.).
  - ▶ Replace aerosol-tight rotor lids and caps after 50 autoclaving cycles.
  - ▶ For QuickLock rotor lids, the seal must be replaced after 50 autoclaving cycles.
  - ▶ **Never** store aerosol-tight rotors or buckets closed.
-

**Safety**

Centrifuge 5804/5804 R/5810/5810 R  
English (EN)

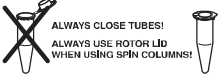
**2.6 Safety instructions on the device**

Symbol	Meaning	Location
	<b>Hazard point</b> ▶ Observe operating manual.	Right side of the device
	<b>CAUTION</b> ▶ Always tighten the rotor with the enclosed rotor key.	Top of device, under the centrifuge lid.
	<b>CAUTION</b> ▶ Seal the vessels. ▶ Use the rotor lid.	Top of device, under the centrifuge lid.
	Warning of biological risks when handling infectious liquids or pathogenic germs.	Aerosol-tight rotors/rotor lids, aerosol-tight aerosol-tight buckets/caps.

### 3 Product description

#### 3.1 Product overview

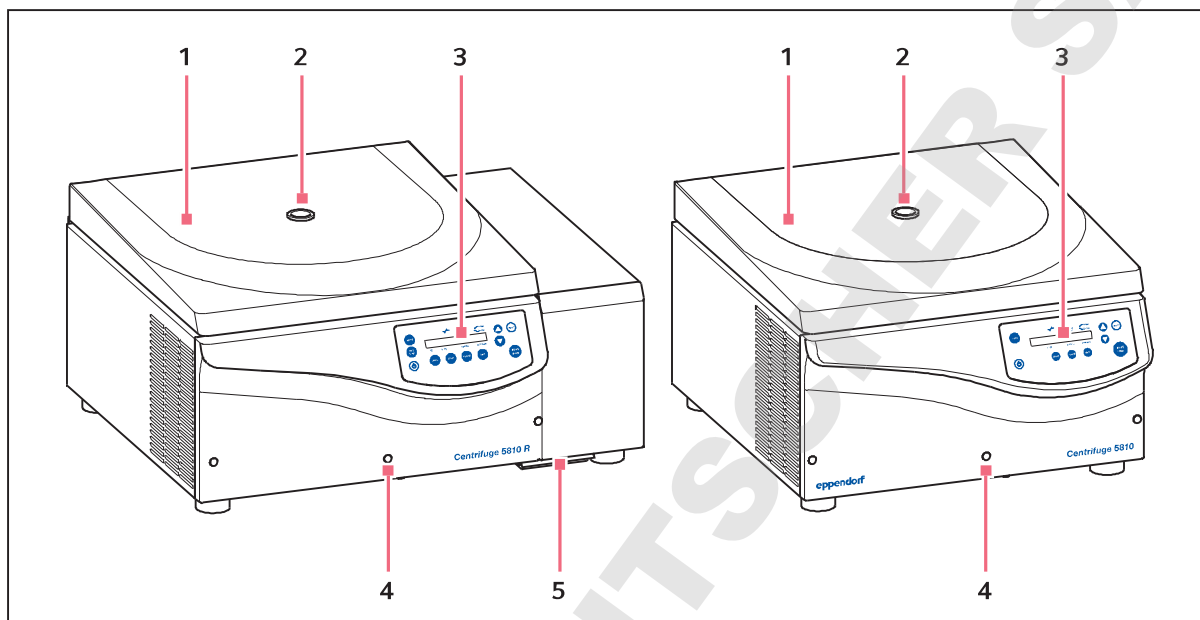

Fig. 3-1: Centrifuge 5810 R and Centrifuge 5810. Centrifuge 5804 R and Centrifuge 5804 are similar in design.

- 1 **Centrifuge lid**
- 2 **Monitoring glass**  
Visual control for rotor stop or option for speed check via stroboscope
- 3 **Operating controls and display**  
(see *Operating controls on p. 25*)
- 4 **Emergency release**  
(see *Emergency release on p. 54*)
- 5 **Condensation water tray (only Centrifuge 5804 R/5810 R)**

#### 3.2 Delivery package

1	Centrifuge 5804/5804 R/5810/5810 R see chapter <i>Ordering information</i> for the corresponding device version, equipment and order numbers
1	Rotor key
1	Mains/power cord
1	Operating manual
1	<b>Only 5804 R/5810 R:</b> condensation water tray

**Product description**

Centrifuge 5804/5804 R/5810/5810 R  
English (EN)



- ▶ Check the delivery for completeness.
- ▶ Check all parts for damage in transit.
- ▶ To safely transport and store the device, keep the transport box and packing material.

### 3.3 Features

The versatile centrifuge has a capacity of maximum 4 × 250 mL (5804/5804 R centrifuge) or 4 × 750 mL (5810/5810 R centrifuge) and reaches a maximum of 20913 × g/14000 rpm. The versatility is reflected in the available rotor options. You can select between 12 (5804/5804 R centrifuge) or 16 (5810/5810 R centrifuge) different rotors to centrifuge the following tubes for your various applications:

- Micro test tubes (0.2 mL to 5.0 mL)
- PCR strips
- Microtainers
- Spin columns
- Cryogenic tubes
- Conical tubes (15 mL/50 mL)
- Bottles (175 mL to 750 mL)
- Various tubes (3 mL to 120 mL)
- Microplates
- PCR plates
- Deepwell plates (max. height of 29 mm)
- Slides (with CombiSlide adapter)
- Cell-culture flasks

Handling the centrifuge is facilitated by:

- Low access height of 29 cm for loading and unloading the rotors
- Automatic rotor detection with rotational speed limit
- Automatic rotor imbalance detection
- Clear digital display

All centrifuges in these series have 35 program slots for user-defined settings and 10 different acceleration and braking ramps.

Adapter-specific manual radius adjustment guarantees maximum RCF accuracy.

The Centrifuge 5804 R/5810 R has an additional temperature control function for centrifugation between -9°C and 40°C. Use the **FastTemp** function to start a temperature control run without samples to adjust the rotor chamber incl. rotor, buckets and adapters quickly to the set temperature. Continuous cooling maintains the temperature after the run has been completed – your samples stay cool.



## 4 Installation

### 4.1 Selecting the location



**NOTICE! If an error occurs, the objects in the immediate proximity of the device will be damaged.**

- ▶ In accordance with the recommendations of EN 61010-2-020, leave a safety clearance of **30 cm** around the device during operation.
- ▶ Please remove all materials and objects from this area.



**NOTICE! Damage from overheating.**

- ▶ Do not place the device near heat sources (e.g., heating, drying cabinet).
- ▶ Do not expose the device to direct sunlight.
- ▶ Ensure unobstructed air circulation. Maintain a clearance of at least 30 cm around all ventilation slits.



**NOTICE! Radio interference.**

This device is a category A product in accordance with EN 55011. There may be disturbance to radio reception in residential areas.

- ▶ Ensure that appropriate preventive measures are taken.

Select the device location according to the following criteria:

- Mains connection as specified on name plate.
- Resonance free table with horizontal even work surface.
- Surrounding area must be well ventilated.
- The location must be protected against direct sunlight.

### 4.2 Preparing installation



**CAUTION! Risk of injury when lifting and carrying heavy loads.**

The device is heavy. Lifting and carrying the device can lead to back injuries.

- ▶ Only lift and transport the device with a sufficient number of helpers.
- ▶ Use a transport aid for transporting the device.

Perform the following steps in the sequence described.

1. Open the box.
2. Remove the covering cardboard.
3. Remove the accessories.
4. Lift the device by the underside in the vicinity of the device feet and place it directly on a suitable lab bench.

**Installation**

Centrifuge 5804/5804 R/5810/5810 R  
English (EN)

### 4.3 Installing the instrument

---

**WARNING! Risk from incorrect supply voltage.**

- ▶ Only connect the device to voltage sources which correspond to the electrical requirements on the name plate.
  - ▶ Only use sockets with a protective earth (PE) conductor and suitable mains/power cord.
- 

**NOTICE! Centrifuge 5804 R/5810 R: Compressor damage after improper transport.**

- ▶ After installation, wait 4 hours before switching on the centrifuge.
- 

1. Allow the device to warm up for at least 3 hours (5804/5810) or 4 hours (5804 R/5810 R) to the ambient temperature to prevent damage to the electronic components from condensation and damage to the compressor (only 5804 R/5810 R).
2. Check that the mains/power supply voltage and mains/power frequency match the requirements on the name plate.  
Centrifuge 5804 R/5810 R with mains/power supply voltage 120 V: See also the notes on the mains/power supply at the end of this chapter.
3. Connect the centrifuge to the mains/power line and switch it on using the mains/power switch on the right side of the device.
  - The **open** key lights up.
  - The display is illuminated.
4. Open the centrifuge lid using the **open** key.
5. Use the details included in the delivery package to check that the delivery is complete.
6. Check all parts for any transport damage. Contact your dealer if any damage is found.
7. **Only 5804 R/5810 R:** Insert the condensation water tray at the front of the device into the provided holder.

Tab. 4-1: Centrifuge 5804 R/5810 R with mains/power supply voltage 120 V in two versions  
**15 A IEC power cable**                      **20 A version**

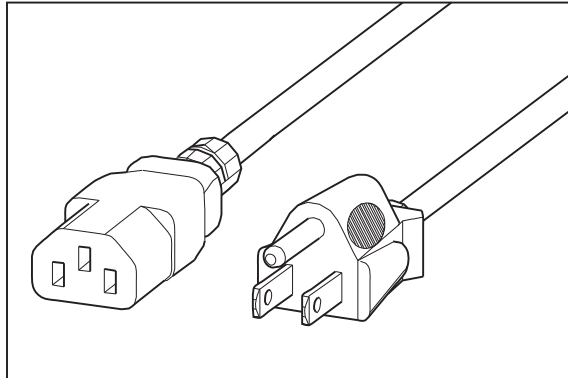

- Conventional IEC power cable.
- Connection to standard socket (120 V/15 A).
- Standard cooling performance:
  - Increased minimum achievable temperatures at maximum speed of centrifugation.
  - Slower cooling down to set temperature.

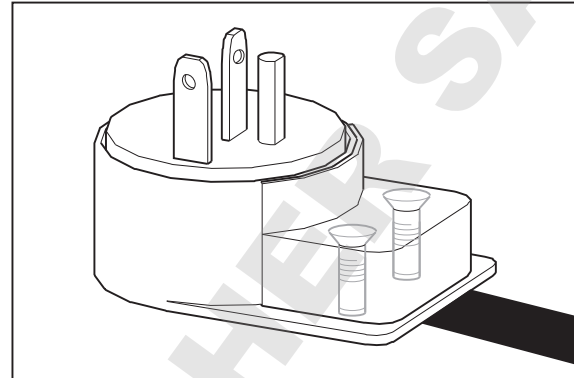

- Mains/power cord fitted permanently to the device.
- Special mains/power connection required (120 V/20 A).
- Increased cooling performance.
  - Lower temperatures at maximum speed of centrifugation possible.
  - Quicker cooling down to set temperature.

DOMINIQUE DUTCHER SAS

**Installation**

Centrifuge 5804/5804 R/5810/5810 R  
English (EN)

DOMINIQUE DUTSCHER SAS

## 5 Operation

### 5.1 Operating controls

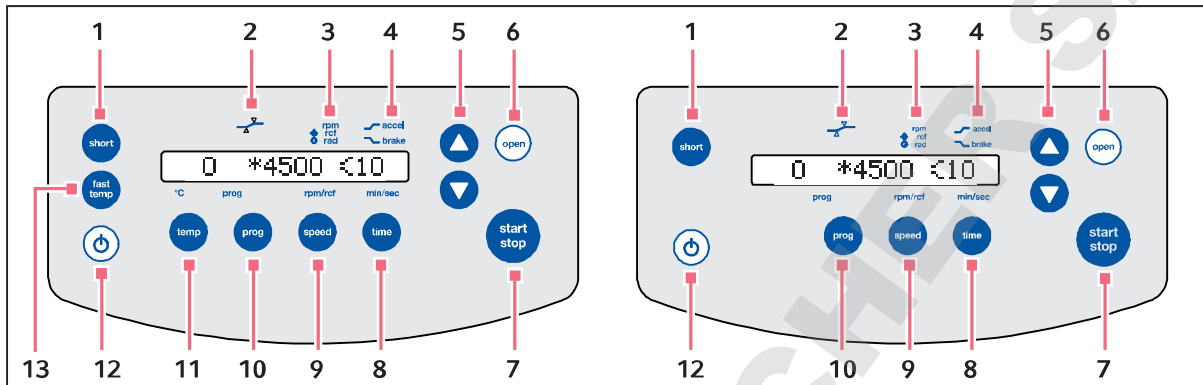

Fig. 5-1: Operating controls of the Centrifuge 5804 R/5810 R and the Centrifuge 5804/5810

- |  |  |
|--|--|
| <p><b>1 short key</b><br/>Short run centrifugation</p> <p><b>2 Status of At set rpm function</b><br/> : Start of time counting when reaching 95 % of the preset <i>g</i> force (rcf) or speed (rpm)<br/> : Start of time counting immediately.</p> <p><b>3 Indicate speed (rpm), <i>g</i> force (rcf) * and radius setting </b>.</p> <p><b>4 Symbol for acceleration  and braking </b></p> <p><b>5 Arrow keys</b><br/>Set parameters and values<br/>Keep the arrow key pressed: quick setting</p> <p><b>6 open key</b><br/>Release lid</p> <p><b>7 start/stop key</b><br/>Start or stop centrifugation</p> | <p><b>8 time key</b><br/>Select runtime setting<br/>Adjust the centrifugation time using the arrow keys</p> <p><b>9 speed key</b><br/>Select the speed of centrifugation and adjust it using the arrow keys</p> <p><b>10 prog key</b><br/>Press the <b>prog</b> key: Load program<br/>Keep the <b>prog</b> key pressed for 2 s: Save current parameters</p> <p><b>11 temp key</b><br/><b>Only 5804 R/5810 R:</b> Select the temperature and adjust it using the arrow keys</p> <p><b>12 Standby  key</b><br/>LED lights green: centrifuge is operational<br/>LED lights red: standby mode is active</p> <p><b>13 fast temp key</b><br/><b>Start Only 5804 R/5810 R:</b> temperature control run FastTemp</p> |
|--|--|

**Operation**

Centrifuge 5804/5804 R/5810/5810 R  
English (EN)

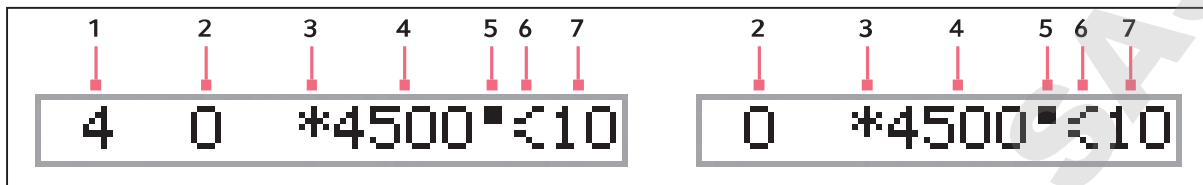

Fig. 5-2: Display of the Centrifuge 5804 R/5810 R and the Centrifuge 5804/5810

- |                                    |  |
|------------------------------------|--|
| 1 Only 5804 R/5810 R: temperature  | 5 Symbol flashes during centrifugation         |
| 2 Program number                   | 6 Symbol for acceleration ↗ and deceleration ↘ |
| 3 Symbol for <i>g</i> force (rcf)  | 7 Centrifugation time                          |
| 4 <i>g</i> force (rcf)/speed (rpm) |  |

**Display of actual value and set value**

- Rotor stop: display of set values
- Centrifugation: display of actual values

**Display set value during centrifugation:** press the **temp**, **time** or **speed** keys. The set value is displayed for 2.5 s.

## 5.2 Preparing for centrifugation

### 5.2.1 Switching on the centrifuge

1. Switch on the centrifuge using the mains power switch or the  standby key.
2. Open the closed centrifuge lid by pressing the **open** key.  
The parameter settings of the last run are displayed.

### 5.2.2 Inserting the rotor

#### Prerequisites

When attaching the rotor to or releasing it from the motor shaft, the temperature of the rotor and motor shaft must be within the range of 10 – 30°C.



**NOTICE! If handled incorrectly, the rotor may fall.**

- ▶ Always pick up the rotor F-35-48-17 with both hands.
- ▶ In order to hold the rotor safely, you may possibly have to remove 3 to 4 sleeves from the opposite outer row.



- ▶ **Swing-bucket rotors:** Remove the buckets before inserting and/or removing the rotor. Use both hands to pick up the rotor cross.

1. Fit the rotor vertically on the motor shaft.
2. Insert the supplied rotor key into the rotor nut.  
**Rotor cross A-4-81/S-4-104:** Use the special rotor key.
3. Turn the rotor key **clockwise** until the rotor nut is firmly tightened.

### 5.2.3 Automatic rotor detection

The centrifuge has automatic rotor detection. It detects a newly inserted rotor and displays its maximum permitted speed for approx. 2 s. g-force (rcf) and speed (rpm) are automatically limited to the maximum permitted value for the rotor.

In order to trigger the rotor detection,

- ▶ Press and hold the **start/stop** key with the centrifuge lid open and turn the rotor counterclockwise by hand.

The display shows the maximum permitted speed for the rotor. g-force (rcf) and speed (rpm) are automatically limited to the maximum permitted value for the rotor.

- ▶ Check the **At set rpm** setting.



Rotor detection can also be triggered by short spin centrifugation:

- ▶ Press the short key until the maximum permitted speed for the rotor appears in the display.



If a centrifugation is started right after a rotor change, the centrifuge has not conducted an automatic rotor detection. The speed set for the previous rotor may exceed the maximum permitted speed for the new rotor. In this case, the centrifuge stops after the automatic rotor detection and displays *SPEED*. The new maximum permitted speed appears in the display. Only select programs only after the automatic rotor detection.

You can then restart the centrifuging with these settings or adjust the speed as necessary.

- ▶ After each rotor change, check whether the new rotor is detected by the device.
- ▶ Check the set g-force (rcf) or speed (rpm) and adjust it if necessary.



## 5.2.4 Loading the rotor



### CAUTION! Risk of injury due to asymmetric loading of the rotor.

- ▶ Load rotors symmetrically with identical tubes or plates and buckets.
- ▶ Always load all positions of a swing-bucket rotor with buckets.
- ▶ Only load adapters with suitable tubes or plates.
- ▶ Always use tubes or plates of the same type (weight, material/density and volume).
- ▶ Check that loading is symmetrical by balancing the adapters and tubes or plates used with scales.



### CAUTION! Risk from damaged or overloaded tubes.

- ▶ When loading the rotor, observe the safety precautions on hazards resulting from overloaded or damaged tubes (see *Warnings for intended use on p. 12*).



The device automatically detects imbalances during operation and stops the run immediately with an error message and a signal tone.

- ▶ Check the load, balance the tubes and restart the run.

### 5.2.4.1 Fixed-angle rotors



#### Rotor lid

- Fixed-angle rotors may only be operated with the appropriate rotor lid in each case. This is clearly shown by the identical rotor name labeling on the rotor and on the rotor lid.
- To carry out an aerosol-tight centrifugation, an aerosol-tight rotor must be used in combination with the corresponding rotor lid or cap.

To load the rotor, proceed as follows:

1. Check the maximum load (adapter, tube and contents) per rotor bore.  
The information about this can be found on the rotor and in this operating manual (see *Rotors on p. 61*).
2. Load rotors and adapters only with the tubes intended for them.
3. Insert tubes opposite each other in pairs into the rotor bores. For symmetric loading, tubes that face each other must be the same type and have the same filling quantity.

**Operation**

Centrifuge 5804/5804 R/5810/5810 R  
English (EN)

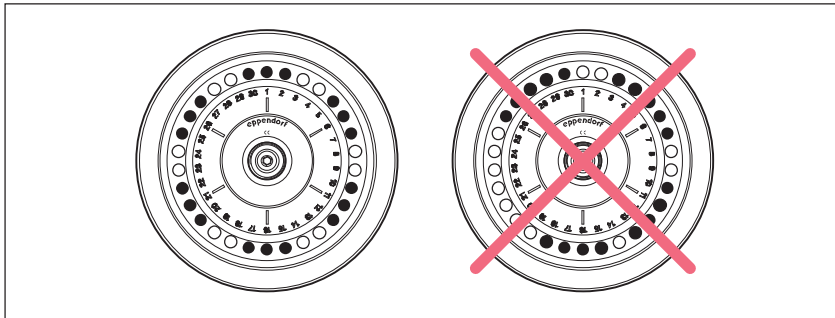

To keep the weight differences between the filled tubes low, we recommend taring with a balance. This will reduce wear on the drive and reduce operating noise.

4. Attach and tighten the rotor lid.

**5.2.4.2 Swing-bucket rotors****Prerequisites**

- A rotor, bucket and adapter combination approved by Eppendorf.
- The buckets are sorted according to the weight class. Opposite-facing buckets must have the same weight class, which is imprinted in the groove: e.g., 68 (the last 2 positions in grams). Please specify the corresponding weight class for reorders - including plate buckets.
- Matching and tested tubes and plates.
- Do not remove the middle guiding elements of the modular adapters of the rectangular buckets in order, e.g., to increase capacity through multi-level centrifugation.

**NOTICE! Damage to adapters due to incorrect stacking.**

- ▶ Stack the adapters in rectangular buckets in a closed row only from the bottom of the bucket. Do not leave any gaps between the modules.

**NOTICE! Filling the plates too high can cause overflowing.**

During the run the menisci in the tubes along the edges of the plates are at an angle. This is due to the centrifugal forces and cannot be avoided.

- ▶ Fill the plate wells to a maximum of 2/3 of the maximum filling volume.

To load the rotor, proceed as follows:

1. Check the bucket grooves for cleanliness and lightly grease them with pivot grease (order no. int.: 5810 350.050/North America: 022634330).  
Contaminated grooves and pegs impede the even swinging of the buckets.
2. Hang the buckets into the rotor.  
All rotor positions must be equipped with buckets.
3. Check to see if all buckets are completely hung and can freely swing out.

### Ensure that everything can swing freely

4. To check whether bottles, plates or tubes can swing freely, swing buckets manually.

### Check swinging direction

5. To check whether the buckets including their load swing with the floor in the direction of the rotor chamber wall, start turning the rotor cross anti-clockwise.
6. Check the maximum load per carrier (adapter, tube or plate and contents) and the loading height.  
The information about this can be found on the rotor and in this operating manual (see *Rotors on p. 61*).
7. Load the buckets symmetrically.

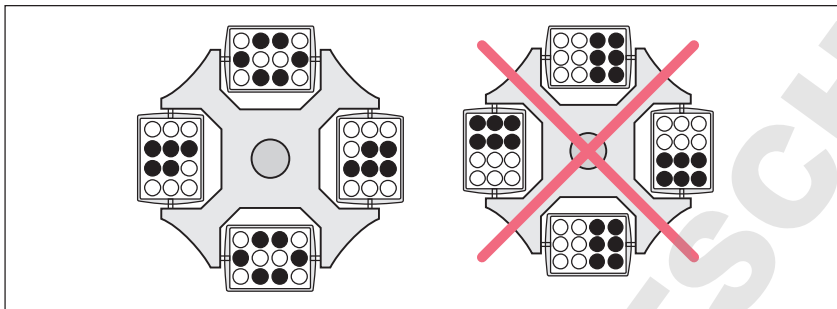

Fig. 5-3: Incomplete, but symmetric loading of the buckets. The pegs of each bucket must be evenly loaded.

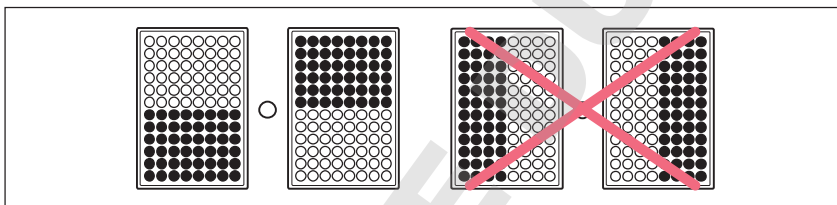

Fig. 5-4: Symmetrical loading of the plates.

The plate charging shown on the right side is incorrect because the bucket cannot correctly swing out. The same principle also applies to the loading of rotor A-4-81-MTP/Flex with 4 plates. The plates have a small amount of play in the buckets.

8. Check the loading of the bucket.

### 5.2.4.3 Rotor S-4x750: Equipping the adapter with vessels > 119 mm



**NOTICE! Broken glass due to incorrect loading.**

If the tubes in a bucket are too long, the swinging tubes will touch the rotor cross and may get damaged or destroyed.

- ▶ Load buckets such that they can swing out freely.
- ▶ If necessary, load only the inner bores.
- ▶ When using tubes with a length of > 100 mm: always perform a manual swing-out test.

If the adapter 16 × 75 mm – 100 mm (order number 5825 736.001) is equipped with vessels > 119 mm in length, e.g., BD 8 mL Vacutainer, there is a risk of glass breakage.

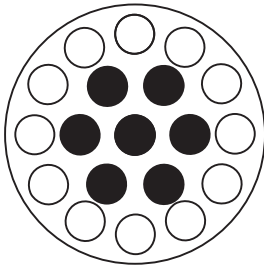

Fig. 5-5: Loading the adapter 16 × 75 - 100 mm with vessels >119 mm in length.

- ▶ Only load the inner bores.

### 5.2.4.4 Mixed loading with buckets and plate carriers

Mixed loading of swing-bucket rotors with buckets and plate carriers is possible if these are intended for the rotor. Buckets or plate carriers which are opposite each other must be buckets/plate carriers of the same type.

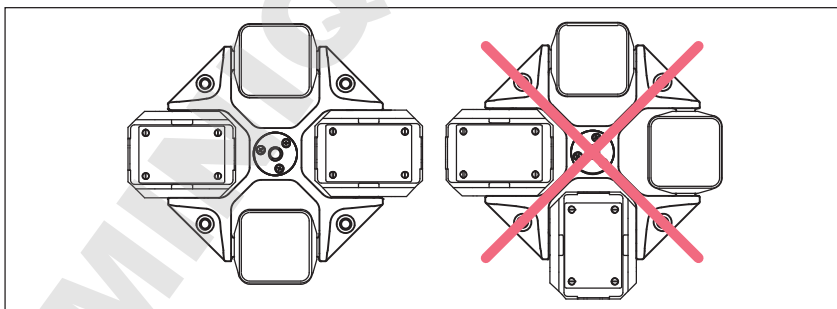

Fig. 5-6: Mixed loading of rotors

Rotor	Mixed loading
S-4-104	<ul style="list-style-type: none"><li>• 2 plate buckets (open bucket or plate bucket)</li><li>• 2 round buckets</li></ul>
A-4-81/A-4-81-MTP/Flex	<ul style="list-style-type: none"><li>• 2 plate buckets (MTP or DWP bucket)</li><li>• 2 buckets for conical tubes</li><li>• 2 rectangular buckets</li></ul>
A-4-44	<ul style="list-style-type: none"><li>• 2 rectangular buckets</li><li>• 2 buckets for conical tubes</li></ul>



**NOTICE! Rotor damage due to mixed loading.**

If you load the rotors A-4-62 and A-4-62-MTP with a mixed equipment, the rotors will be damaged during centrifugation.

- ▶ Load all positions of the rotors A-4-62 and A-4-62-MTP with the same buckets.
- ▶ Always load all 4 positions of the swing-bucket rotors.

- ▶ Check the loading of the bucket.

### 5.2.5 Closing the centrifuge lid



**WARNING! Risk of injury when opening or closing the centrifuge lid.**

There is a risk of crushing your fingers when opening or closing the centrifuge lid.

- ▶ When opening or closing the centrifuge lid, do not reach between the lid and device or into the latching mechanism of the lid.
- ▶ Always open the centrifuge lid completely to prevent it from falling.

1. Check the correct attachment of the rotor and rotor lid.
2. Push down the centrifuge lid until the lid latch engages and the lid is automatically closed.

The centrifuge will close automatically.

The **open** key lights up blue. The ■ symbol appears in the display.

**Operation**

Centrifuge 5804/5804 R/5810/5810 R  
English (EN)

**5.3 Cooling (only 5804 R/5810 R)****5.3.1 Temperature adjustment**

- ▶ Select the temperature setting using the **temp** key.
- ▶ Set the temperature using the arrow keys between -9°C and +40°C.

**5.3.2 Temperature display**

If the rotor is stopped: Target temperature  
During centrifugation: Actual temperature

**5.3.3 Temperature monitoring**

After the target temperature has been reached, the centrifuge reacts to temperature deviations during centrifugation as follows:

Deviation from set value	Action
± 3 °C	Temperatures on the display are flashing.
± 5 °C	Periodic warning tone. Centrifugation is stopped automatically.

**5.3.4 FastTemp**

This function can be used to start a temperature control run directly without samples with a rotor and temperature-specific speed in order to quickly adjust the rotor chamber, including the rotor, buckets and adapters, to the previously set nominal temperature.

## Prerequisites

- The centrifuge is switched on.
- The rotor and rotor lid are properly attached.
- The centrifuge lid is closed.
- Temperature and g-force (rcf)/speed (rpm) for the centrifugation are set (see *Centrifuging on p. 36*).

1. Press the **fast temp** key.

The display shows from left to right: actual temperature value, *FT*, g-force (rcf)/speed (rpm) and -- (time).

The temperature control run automatically ends when the set temperature is reached. A periodic signal tone sounds.

2. Press the **start/stop** key to terminate the temperature control run early.

After the set temperature has been reached and the temperature control run is complete, the centrifuge keeps the rotor chamber with the centrifuge lid closed at the set target temperature if the temperature is below the ambient temperature. However, independent of the target temperature, 4 °C must be met via this continuous cooling in order to prevent the rotor chamber from freezing.



The centrifuge stops the cycle automatically if the rotor or the buckets have reached the set temperature. Therefore, there may be a delay of approx. 30 min between the display of the set temperature and the automatic end of the temperature control run.



When using aerosol-tight buckets, always carry out a FastTemp run at low temperatures without a cap. There is a danger otherwise of the caps becoming fixed by suction due to a vacuum. Do not pull on the sealing clamps or hooks to loosen the cap. Adjust the temperature of the buckets to room temperature so that the caps can be removed easily.

### 5.3.5 Continuous cooling

If the rotor stops, the rotor chamber will be maintained at the target temperature if the following requirements have been met:

- The centrifuge is switched on.
- The centrifuge lid is closed.
- The target temperature is lower than the ambient temperature.
- The centrifuge is not in standby mode.

During continuous cooling the following applies:

- The set and actual temperature are displayed alternately.
- Irrespective of the set temperature, the temperature does not go below 4 °C to prevent the rotor chamber from freezing and from increased condensation in the device.
- The temperature adjustment is slower because the rotor does not rotate during this process.

To end continuous cooling, open the centrifuge lid or press the standby key.

If the centrifuge is not used for more than 8 hours, the continuous cooling is switched off automatically (ECO shut-off). The device then switches to standby mode. This protects against ice formation in the rotor chamber and increased condensation in the device. With **FastTemp** you can quickly reach the desired temperature again (see p. 34).

You can also change from automatically switching off continuous cooling after 8 hours (ECO shut-off) to unlimited continuous cooling.



#### **NOTICE! Ice formation and compressor overheating during continuous cooling.**

- ▶ Switch the centrifuge off regularly to eliminate any ice formation by thawing.
- ▶ Regularly remove condensation from the rotor chamber using a soft, absorbent cloth.
- ▶ Empty and clean the condensation water tray regularly.

1. When the centrifuge lid is opened, press the **temp** and **prog** keys simultaneously.  
*Standby 8h* appears in the display.
2. Press the **fast temp** key immediately.  
Endless operation for continuous cooling is activated. *Standby endless* appears in the display.
3. To change back to *Standby 8h*, repeat the process.

## 5.4 Centrifuging



### CAUTION! Risk from incorrectly loaded rotors and damaged/overloaded tubes!

- ▶ Before commencing centrifugation, follow the safety instructions relating to risks from asymmetrically loaded and/or overloaded rotors and from overloaded, damaged and/or open tubes (see *Warnings for intended use on p. 12*).



### WARNING! Risk of injury from improperly attached rotors, rotor lids and caps.

- ▶ Only centrifuge with a firmly tightened rotor and rotor lid as well as with inserted carriers, buckets and correctly closed caps.
- ▶ If unusual noises occur when the centrifuge starts, the rotor, the rotor lid or a cap may not be properly secured. Immediately press the **start/stop** key to stop centrifuging.

Each of the centrifuging variants described here must be preceded by the preparation described above (see *Preparing for centrifugation on p. 27*).

### 5.4.1 Centrifugation with time setting

Perform the following steps in the sequence described.

1. Speed (rpm) setting: press once. g-force (rcf) setting: press repeatedly until the symbol  additionally appears in the display.  
The displayed g-force (rcf)/speed (rpm) flashes and can be set with the arrow keys.  
For the g-force (rcf) setting also check the set radius (see *Rotors on p. 61*), (see *Setting the radius on p. 41*).
2. Use the arrow keys to set the g-force (rcf)/speed (rpm).  
The new set value appears in the display.
3. Select the runtime setting and set it with the arrow keys.
4. **Only 5804 R/5810 R:** Select the temperature setting and set it with the arrow keys.





5. Start centrifugation.

- ■ blinks in the display when the rotor is running.
- **Only 5804 R/5810 R:** The current temperature will be displayed.
- The current g-force (rcf)/speed (rpm) of the rotor is displayed.
- You can display all set values for 2.5 s by pressing a parameter key (**Temp, Speed, Time**).
- You can terminate centrifugation early by pressing the **start/stop** key.
- The centrifuge automatically stops after the set time has elapsed.
- The elapsed centrifugation will be shown in a blinking display during the braking process.



6. Open the centrifuge lid as soon as the key lights up.



During the run you can modify the total run time, the temperature (only Centrifuge 5804 R/ 5810 R) and the g-force (rcf)/speed (rpm) as well as the acceleration time and the braking time. The new parameters are adopted immediately. The time which has already elapsed is considered in the newly set total run time. Please note that the shortest new total run time that can be set is the elapsed time plus 2 minutes.

## 5.4.2 Centrifuging in continuous operation

Perform the following steps in the sequence described.

1. Set the g-force (rcf)/speed (rpm) and possibly the temperature as previously described (see p. 36).



2. Select the runtime setting.



3. Set continuous operation below 1 min or above 99 min.  
In the display ∞ indicates continuous run.



4. Start centrifugation.

- ■ blinks in the display when the rotor is running.
- If the centrifuge runs for more than 99 min, 99. appears in the display.
- **Only 5804 R/5810 R:** The current temperature will be displayed.
- The current g-force (rcf)/speed (rpm) of the rotor is displayed.



5. End centrifugation after the desired time.

- The elapsed centrifugation will be shown in a blinking display during the braking process.



6. Open the centrifuge lid as soon as the key lights up.



**Operation**

Centrifuge 5804/5804 R/5810/5810 R  
English (EN)





### 5.4.3 Short spin centrifugation

You can carry out a short spin centrifugation with the currently set or with the maximum g-force (rcf)/ speed (rpm) of the used rotor.

#### 5.4.3.1 Setting the speed option

-  ▶ Press and hold down the key with the centrifuge lid open.  
One of the following options appears in the display:  
*rpm max*: the rotor accelerates up to its maximum g-force (rcf)/speed (rpm) (see *Rotors on p. 61*).  
*200 - rpm*: the rotor only accelerates up to its set g-force (rcf)/speed (rpm).
-  ▶ Press and hold down the key for more than 3 s with the centrifuge lid open to switch between the *rpm max* and *200 - rpm* options.  
The selected option appears in the display for 2 s and is retained.

#### 5.4.3.2 Starting the short spin centrifugation

1. If *200 - rpm* is set, set the g-force (rcf)/ speed (rpm) for the short spin centrifugation (see p. 36).
2. **Only 5804 R/5810 R:** set temperature (see p. 36).
-  3. Keep the key pressed to start the short spin centrifugation.
  - *SH* appears in the display while the rotor is running.
  - The time is counted upwards in seconds.
-  4. Release to end the short spin centrifugation.
-  During the braking process, you can restart the centrifugation up to two times by pressing the **short** key again.
-  5. Open the centrifuge lid as soon as the key is illuminated.

#### 5.4.4 Removing the rotor

##### Prerequisites

When attaching the rotor to or releasing it from the motor shaft, the temperature of the rotor and motor shaft must be within the range of 10 – 30°C.



**NOTICE! If handled incorrectly, the rotor may fall.**

The swing-bucket rotor may fall if the buckets are used as handles.

- ▶ Remove the buckets before inserting and/or removing a swing-bucket rotor.
- ▶ Always use both hands to carry the rotor cross.



**NOTICE! If handled incorrectly, the rotor may fall.**

- ▶ Always pick up the rotor F-35-48-17 with both hands.
- ▶ In order to hold the rotor safely, you may possibly have to remove 3 to 4 sleeves from the opposite outer row.

1. Turn the rotor nut **counterclockwise** using the rotor key.
2. Remove the rotor by lifting it vertically.
3. **Only 5804 R/5810 R:** Switch off the centrifuge after use and empty the condensation water tray. Leave centrifuge lid fully opened and protect it against closing.

#### 5.4.5 Standby mode

- ▶ You can switch between standby mode and ready state at any time when centrifugation is not performed by pressing the standby key.

##### Standby mode

- The display expires.
- The standby key lights red.
- **Only 5804 R/5810 R:** The rotor chamber is not cooled (see *Continuous cooling on p. 35*).

##### Ready state

- The centrifugation parameters are displayed.
- The standby key lights up in green.
- **Only 5804 R/5810 R:** The rotor chamber is cooled when the centrifuge lid is closed (see *Continuous cooling on p. 35*).

**Operation**







Centrifuge 5804/5804 R/5810/5810 R  
English (EN)

DOMINIQUE DUTSCHER SAS

## 6 Operating controls and function









### 6.1 Setting the radius



When you control the rotational speed via the  $g$ -force (rcf, RCF), and not via the speed (rpm), the internal conversion of speed to  $g$ -force takes place by default with the largest radius of the used rotor. (see *Rotors on p. 61*). You can adapt this radius to an applied adapter:

-  1. Press several times until the  symbol also appears in the display.  
The current radius flashes.
-  /  2. Set the new radius.
-  /  3. Wait for 3 seconds (if the rotor is stopped: 10 seconds).  
The changed  $g$ -force appears.

### 6.2 Setting the acceleration and braking times

You can set the acceleration and braking time in the levels 0 to 9 (see Tab. on p. 60). Level 9 is preset (shortest acceleration and braking time).

-  1. Press twice until the  symbol for acceleration level (accel) appears in the display.
-  /  2. Select acceleration level 0 to 9.
-  3. Press once until the  symbol for braking level (brake) appears in the display.
-  /  4. Select braking level 0 to 9.  
Braking level (brake) 0 corresponds to free deceleration.

The device only shows the  and  symbols continually when levels 0 to 8 have been set.

### 6.3 Setting the start of run time (At set rpm)

The centrifuge can count down the set time either immediately from the start of centrifugation or only once 95% of the specified g-force (rcf)/speed (rpm) has been reached (At set rpm). The respective setting is indicated by the flashing triangle in the symbol above the display:



Preset time: the set time is counted down immediately after the start of centrifugation.



At set rpm: the set time is counted down once 95% of the specified g-force (rcf)/speed (rpm) has been reached.

Prerequisites

The centrifuge lid is open.



- ▶ Hold down this key for at least 4 s to switch between the two settings,

When pressing the key, both triangles of the symbol will flash in turn.

### 6.4 Saving the program

You can save the current centrifugation parameters and functions (*At set rpm*, acceleration and braking times and radius) under up to 35 program numbers.

Prerequisites

Rotor stop.

1. Check the parameters and functions to be saved.
2. Press key twice.  
 The first free program number appears with *P...* in the display.
3. Select the program number (*1...9,A...Z*).
4. Press and hold key for 2 seconds.  
*ok* appears in the display. The current centrifugation parameters and functions are saved under the selected program number.



When you want to overwrite a saved program, you have to delete it before saving the new parameters (see *Deleting the program on p. 43*).

## 6.5 Loading the program

### Prerequisites

- Rotor stop.



1. Press once.  
Program number flashes:
  - 0: centrifugation parameters and functions of the last run.
  - 1...9, A...Z: stored programs.



2. Select the program number.



3. Closed centrifuge lid: centrifugation starts with the loaded centrifugation parameters and functions.  
When the centrifuge lid is open, you can press the **start/stop** key to return to program 0 or exit the programming mode.



If you change the centrifugation parameters during a run with a stored program, the centrifuge changes to program 0. The stored program remains unchanged.  
You can also exit the stored program by loading program 0.

## 6.6 Deleting the program

### Prerequisites

- Rotor stop.
- The centrifuge lid is open.



1. Press once.  
The program number flashes.



2. Select the program number.



3. Within 10 seconds, keep key pressed for 2 seconds  
The following text appears in the display: *cleared*.  
The selected program is deleted. You can save new centrifugation parameters and functions under this program number.

## 6.7 Special functions

### 6.7.1 Display operating hours

#### Prerequisite

Rotor stop.



- ▶ Press both keys simultaneously.  
The previous total run time of the centrifuge (in hours) appears in the display.

### 6.7.2 Switching on/off the warning signal



- ▶ Press both keys simultaneously to change the setting.  
*Alarm on* or *Alarm off* appears in the display after 2 s.

### 6.7.3 Exiting the service functions



- ▶ Press both keys simultaneously to exit a service function called by mistake.



## 7 Maintenance

### 7.1 Maintenance



**WARNING! Risk of injury due to defective gas spring(s).**

A defective gas spring is an insufficient support for the centrifuge lid. There is a risk of crushing fingers or limbs.

- ▶ Make sure that the centrifuge lid can be opened completely and that it will remain in this position.
- ▶ Regularly check all gas springs for their proper function.
- ▶ Have defective gas springs replaced immediately.
- ▶ Have gas springs replaced by a service technician every 2 years.

We recommend that the centrifuge with the associated rotors be checked at the latest every 12 months by Technical Service during maintenance. Observe the relevant national regulations.

### 7.2 Preparing cleaning/disinfection

- ▶ Clean all accessible surfaces of the device and the accessories at least weekly and when contaminated.
- ▶ Clean the rotor regularly. This way the rotor is protected and the durability is prolonged.
- ▶ Furthermore, observe the notes on decontamination (see *Decontamination before shipment on p. 49*) when the device is sent to the authorized Technical Service for repairs.

The procedure described in the following chapter applies to the cleaning as well as to the disinfection or decontamination. The table below describes the steps required on top of this:

Cleaning	Disinfecting/decontamination
<ol style="list-style-type: none"> <li>1. Use a mild cleaning fluid to clean the accessible surfaces of the device and the accessories.</li> <li>2. Carry out the cleaning as described in the following chapter.</li> </ol>	<ol style="list-style-type: none"> <li>1. Choose the disinfection method which corresponds to the legal regulations and guidelines in place for your range of application. For example, use alcohol (ethanol, isopropanol) or alcohol-based disinfectants.</li> <li>2. Carry out the disinfection or decontamination as described in the following chapter.</li> <li>3. Then clean the device and the accessories.</li> </ol>



If you have any further questions regarding the cleaning and disinfection or decontamination or regarding the cleaning fluid to be used, contact the Eppendorf AG Application Support. The contact details are provided on the back of this manual.

## 7.3 Cleaning/disinfection

---



### **DANGER! Electric shock as a result of penetration of liquid.**

- ▶ Switch off the device and disconnect the mains/power plug before starting cleaning or disinfection work.
  - ▶ Do not allow any liquids to penetrate the inside of the housing.
  - ▶ Do not spray clean/spray disinfect the housing.
  - ▶ Only plug the device back in if it is completely dry, both inside and outside.
- 



### **NOTICE! Damage from the use of aggressive chemicals.**

- ▶ Do not use any aggressive chemicals on the device or its accessories, such as strong and weak bases, strong acids, acetone, formaldehyde, halogenated hydrocarbons or phenol.
  - ▶ If the device becomes contaminated with aggressive chemicals, clean it immediately using a mild cleaning agent.
- 



### **NOTICE! Corrosion due to aggressive cleaning agents and disinfectants.**

- ▶ Do not use corrosive cleaning agents, aggressive solvents or abrasive polishes.
  - ▶ Do not incubate the accessories in aggressive cleaning agents or disinfectants for a longer period of time.
- 



### **NOTICE! Damage from UV and other high-energy radiation.**

- ▶ Do not use UV, beta, gamma, or any other high-energy radiation for disinfecting.
  - ▶ Avoid storage in areas with strong UV radiation
- 



### **Autoclaving**

Except for the rotor crosses A-4-81, S-4-72 and S-4-104, all rotors, rotor lids, buckets, carriers, caps and adapters can be autoclaved (121 °C, 20 min).

After a maximum of 50 autoclaving cycles, the caps and, for QuickLock rotors, the seals must be replaced.

Do not use any stained, porous or otherwise defective seals. Also note the operating manual of the centrifuge and the supplement sheet on aerosol-tight centrifugation delivered together with the aerosol-tight rotors.

The aerosol-tight rotor FA-45-30-11 can be autoclaved at 142°C for 2 hours to destroy prions.

In this case note that the rotor lid must be replaced after each autoclaving.



#### **Aerosol tightness**

Check that the seals are intact before use.

Only QuickLock rotor lid: Replace the sealing ring in the lid groove when it becomes worn. Replace the rotor lids with screw cap when the sealing rings on the lid screw and in the lid groove become worn.

The sealing rings require regular care to protect the rotors.

Aerosol-tight rotors should never be stored with lids screwed on!

In order to prevent damage, lightly lubricate the lid thread of the aerosol-tight rotors with pivot grease (order no. Int.: 5810 350.050/North America: 022634330).



#### **Swing-bucket rotor**

- Before cleaning the rotor, remove old pivot grease from grooves and pivots.
- Make sure that the grooves and pivots are clean. Dirty grooves and pivots prevent carriers from swinging out evenly.
- After cleaning, lubricate the pivots of the rotor and the grooves of the buckets with pivot grease (order no. Int.: 5810 350.050/North America: 022634330) so that the carriers can move freely in a swinging manner.

### **7.3.1 Cleaning and disinfecting the device**

1. Open the lid. Switch off the device with the mains/power switch. Disconnect the power plug from the power supply.
2. Loosen the rotor nut by turning the rotor key **counterclockwise**.
3. Remove the rotor.
4. Clean and disinfect all accessible surfaces of the device, including the power cable, using a damp cloth and the recommended cleaning agents.
5. Thoroughly clean the rubber seal of the rotor chamber with water.
6. Rub the dry rubber seal with glycerine or talcum powder to prevent it from becoming brittle. Other components of the device, such as the lid latch, lid springs, motor shaft and rotor cone, must not be lubricated.
7. Clean the motor shaft with a soft, dry and lint-free cloth. Do not lubricate the motor shaft.
8. Check the motor shaft for damage.
9. Inspect the device for corrosion and damage.
10. Leave the centrifuge lid open when the device is not being used.
11. Only connect the device to the power supply if it is fully dry inside and out.

### 7.3.2 Cleaning and disinfecting the rotor



After every 200 runs, the centrifuge displays *clean rotor* three times to remind you about the regular rotor cleaning.

1. Inspect the rotor and accessories for damage and corrosion. Do not use any damaged rotors or accessories.
2. Clean and disinfect the rotors and accessories with the recommended cleaning agents.
3. Use a bottle brush to clean and disinfect the rotor bores.
4. Rinse the rotors and accessories thoroughly with distilled water. Rinse the rotor bores of fixed-angle rotors particularly thoroughly.



Do not immerse the rotor in liquid as liquid can get trapped inside the cavities.

5. Place rotors and accessories on a cloth to dry. Place fixed-angle rotors with the rotor bores facing downwards to allow the bores to also dry.
6. Clean the rotor cone with a soft, dry and lint-free cloth. Do not lubricate the rotor cone.
7. Inspect the rotor cone for damage.
8. Place the dry rotor onto the motor shaft.
9. Tighten the rotor nut firmly by turning it **clockwise** with the rotor key.
10. Load the fixed-angle rotor with the cleaned adapters or the swing-bucket rotor with the cleaned buckets and adapters, if necessary.
11. Leave the rotor lid open when the rotor is not being used.

### 7.4 Additional care instructions for refrigerated centrifuges

- ▶ Empty and clean the condensation water tray regularly and especially after liquid spillage in the rotor chamber. Pull out the condensation water tray at the front right under the device.
- ▶ Clean the condensation water drain on a regular basis, too, e.g., using a bottle brush.
- ▶ Regularly free the rotor chamber from ice formations by thawing, by either leaving the centrifuge lid open or by performing a short temperature control run at approx. 30 °C.
- ▶ To take pressure off the gas spring(s), leave the centrifuge lid open if the centrifuge is not used for a longer period.  
Residual moisture can escape.
- ▶ Wipe up the condensation water in the rotor chamber. Use a soft, absorbent cloth for this.
- ▶ No later than every 6 months, remove any dust deposits from the ventilation slits of the centrifuge using a brush or swab. First switch off the device and remove the power plug.

## 7.5 Breakage of glass

When using glass tubes there is a risk of glass breakage in the rotor chamber. The resulting glass splinters are swirled around in the rotor chamber during centrifugation and have a sandblasting effect on the rotor and accessories. Very small glass particles become lodged in the rubber parts (e.g., the motor sleeve, the rotor chamber seal, and the rubber mats of adapters).



### **NOTICE! Glass breakage in the rotor chamber**

Glass tubes in the rotor chamber may break if the  $g$ -force is too high. Broken glass can damage the rotor, accessories and samples.

- ▶ Please note the manufacturer's information on the recommended centrifugation parameters (load and speed).

### **Effects of glass breakage in the rotor chamber:**

- Fine black metal abrasion in the rotor chamber (in metal rotor chambers).
- The surfaces of the rotor chamber and accessories are scratched.
- The chemical resistance of the rotor chamber is reduced.
- Contamination of samples.
- Wear on rubber parts.

### **How to proceed in case of glass breakage**

1. Remove all splinters and glass powder from the rotor chamber and accessories.
2. Thoroughly clean the rotor and rotor chamber. Thoroughly clean the bores of the fixed-angle rotors, in particular.
3. If required, replace the rubber mats and adapters to prevent any further damage.
4. Regularly check the rotor bores for deposits and damage.

## 7.6 Decontamination before shipment

If you are shipping the device to the authorized Technical Service for repairs or to your authorized dealer for disposal please note the following:



### **WARNING! Risk to health from contaminated device**

1. Follow the instructions in the decontamination certificate. You can find it as a PDF file on our website ([www.eppendorf.com/decontamination](http://www.eppendorf.com/decontamination)).
2. Decontaminate all the parts you would like to dispatch.
3. Include the fully completed decontamination certificate in the packing.

DOMINIQUE DUTSCHER SAS

## 8 Troubleshooting

If you cannot remedy an error with the recommended measures, please contact your local Eppendorf partner. The contact addresses can be found on the Internet at [www.eppendorf.com](http://www.eppendorf.com).

### 8.1 Resetting the excess current switch

The 230 V and 120 V devices have built-in thermal excess-current switches which function as (all-pole) fuses. When the overload protection is actuated, these switch the power switch to OFF, but do not switch it on again automatically.

To switch on the excess current switch again, proceed as follows:

1. Switch off the centrifuge using the power switch.
2. Wait for at least 20 seconds and switch on the centrifuge again.

The excess current switch will be automatically reactivated and the centrifuge is ready for operation.

### 8.2 General errors

Problem	Cause	Solution
No display.	No mains/power connection.	▶ Check the mains/power connection.
Display shows <i>Interrupt</i> after the centrifuge has been switched on.	Mains/power outage.	<ul style="list-style-type: none"> <li>▶ Check the mains/power fuse of the device (see <i>Resetting the excess current switch on p. 51</i>).</li> <li>▶ Check the mains/power fuse of the laboratory.</li> <li>▶ Press the <b>open</b> key.</li> </ul>
Lid of the device cannot be opened.	Rotor is still running.	▶ Wait for rotor to stop.
	Mains/power outage.	<ol style="list-style-type: none"> <li>1. Check the mains/power fuse of the device (see <i>Resetting the excess current switch on p. 51</i>).</li> <li>2. Check the mains/power fuse of the laboratory.</li> <li>3. Activate the emergency lid release (see p. 54).</li> </ol>
<i>clean rotor</i>	200 runs.	▶ Clean the rotor and rotor chamber (see p. 45).
Centrifuge brakes during a short run centrifugation, although the <b>short</b> key is pressed.	The <b>short</b> key was released briefly more than twice (protective function for the drive).	▶ Press the <b>short</b> key continuously during a short run centrifugation.

### 8.3 Error messages

If one of the following error messages appears, proceed as follows:

1. Remove fault (see Solution).
2. Press the **open** key to clear the error message.
3. If necessary, repeat centrifugation.

Some errors can have various causes. The actual cause is described in the message in the device display.

Problem	Cause	Solution
<i>no rotor</i> Centrifuge does not start up.	No rotor.	▶ Insert the rotor.
<i>no rotor</i> Centrifuge does not start up.	Error in the drive or in the rotor detection.	▶ Switch the centrifuge off and back on again after > 20 s.
<i>Press Open</i>	Centrifuge lid could not be locked.	1. Press the <b>open</b> key. 2. Try again to close centrifuge lid.
<i>Close lid</i>	Centrifuge lid not closed properly.	▶ Close the centrifuge lid firmly.
<i>Lift lid</i> The centrifuge lid does not open.	The centrifuge lid cannot open automatically.	▶ Lift the centrifuge lid manually.
<i>IMBAL</i> The centrifuge shakes when it accelerates and switches off.	Rotor is asymmetrically loaded.	▶ Load the rotor symmetrically (see p. 27).
<i>ROTOR</i> The centrifuge shakes when it accelerates and switches off.	Rotor not sufficiently tightened.	1. Tighten the rotor nut (see p. 27). 2. Check the rotor cone and motor shaft for grooves and damage.
<i>ROTOR</i> The centrifuge shakes when it accelerates and switches off.	<ul style="list-style-type: none"> <li>• Centrifuge was pushed.</li> <li>• Table is not stable.</li> </ul>	▶ Position the centrifuge on a stable table (see p. 21).
<i>SPEED</i> Centrifuge switches off.	Nominal speed too high for rotor.	▶ Enter the appropriate nominal speed (see p. 61).
<i>change rotor</i>	The maximum service life of the rotor has been reached. The warning is displayed after 98,000, 99,000 and 99,600 runs (3 times after each run). After 100,000 runs, it is displayed after every run.	▶ Contact Technical Service.



<b>Problem</b>	<b>Cause</b>	<b>Solution</b>
Temperature display flashes. (only 5804 R/5810 R)	Temperature deviation from set value: $\pm 3$ °C.	<ul style="list-style-type: none"> <li>▶ Check the settings.</li> <li>▶ Wait until the set temperature has been reached.</li> <li>▶ Check unhindered air circulation through the air slots.</li> <li>▶ Thaw ice or switch off device and allow it to cool down.</li> </ul>
<i>Overtemp</i> (only 5804 R/5810 R) Centrifuge switches off and issues a warning tone.	Temperature deviation from set value in the rotor chamber: $\pm 5$ °C.	<ul style="list-style-type: none"> <li>▶ Check the settings.</li> <li>▶ Check unhindered air circulation through the air slots.</li> <li>▶ Thaw ice or switch off device and allow it to cool down.</li> </ul>
<i>Clear memory</i>	Program memory full.	▶ Delete some programs (see p. 43).
<i>Interrupt</i>	Mains/power failure during a run.	▶ Check the mains/power connection.
<i>Error 1</i>	Error in the rotational speed measurement system.	▶ If this error message appears again, test with a different rotor.
<i>Error 2</i>	Imbalance sensor faulty.	▶ Repeat the run.
<i>Error 3</i>	Error in the rotational speed measurement system.	▶ Insert rotor and tighten.
<i>Error 3</i>	Error in the rotational speed measurement system.	▶ Allow the centrifuge to stand for 12 min when switched on until the <b>open</b> key lights up.
<i>Error 4</i>	Lid latch sensor faulty.	▶ Switch the centrifuge off and back on again after > 20 s.
<i>Error 5</i>	Prohibited opening of lid or lid switch is defective during a run.	<ol style="list-style-type: none"> <li>1. Wait for rotor to stop.</li> <li>2. Open the centrifuge lid and close it again.</li> <li>3. Repeat the run.</li> </ol>
<i>Error 6 or overload</i>	Mains voltage too low.	▶ Check the mains/power supply voltage.
<i>Error 6 or overload</i>	<ul style="list-style-type: none"> <li>• Frequency converter overloaded.</li> <li>• Brake faulty.</li> </ul>	▶ Switch off centrifuge, allow to cool down for at least 5 min, and then switch on again.
<i>Error 8</i>	<ul style="list-style-type: none"> <li>• Drive fault.</li> <li>• Rotor loose.</li> <li>• Motor defective.</li> </ul>	<ol style="list-style-type: none"> <li>1. Wait for rotor to stop.</li> <li>2. Tighten the rotor.</li> <li>3. Repeat the run.</li> </ol>
<i>Error 9 to Error 25</i>	Electronics fault.	▶ Switch the centrifuge off and back on again after > 20 s.

## 8.4 Emergency release

If the centrifuge lid cannot be opened, you can activate the emergency release manually.



**WARNING! Risk of injury from rotating rotor.**

If the emergency release of the lid is operated, the rotor may continue rotating for several minutes.

- ▶ Wait for the rotor to stop before activating the emergency release.
  - ▶ To check, look through the monitoring glass in the centrifuge lid.
- 

You need the standard rotor key supplied with the centrifuge.

1. Disconnect the power plug.
2. Remove the plastic cover for the emergency release. This is located in the center on the front side of the device.
3. Insert the rotor key into the hexagonal opening behind until some resistance can be felt.
4. While keeping the rotor key pressed, turn it in a counterclockwise direction.  
This will release the centrifuge lid.
5. Open the centrifuge lid.
6. Remove the rotor key and put the plastic covers back on.

## 9 Transport, storage and disposal

### 9.1 Transport



**CAUTION! Risk of injury when lifting and carrying heavy loads.**

The device is heavy. Lifting and carrying the device can lead to back injuries.

- ▶ Only lift and transport the device with a sufficient number of helpers.
- ▶ Use a transport aid for transporting the device.

- ▶ Remove the rotor from the centrifuge before transport.
- ▶ Use the original packing for transport.

	Air temperature	Relative humidity	Atmospheric pressure
General transport	-25 °C – 60 °C	10 % – 75 %	30 kPa – 106 kPa
Air freight	-20 °C – 55 °C	10 % – 75 %	30 kPa – 106 kPa

### 9.2 Storage

	Air temperature	Relative humidity	Atmospheric pressure
In transport packing	-25 °C – 55 °C	10 % – 75 %	70 kPa – 106 kPa
Without transport packing	-5 °C – 45 °C	10 % – 75 %	70 kPa – 106 kPa

### 9.3 Disposal

In case the product is to be disposed of, the relevant legal regulations are to be observed.

#### **Information on the disposal of electrical and electronic devices in the European Community:**

Within the European Community, the disposal of electrical devices is regulated by national regulations based on EU Directive 2012/19/EU pertaining to waste electrical and electronic equipment (WEEE).

According to these regulations, any devices supplied after August 13, 2005, in the business-to-business sphere, to which this product is assigned, may no longer be disposed of in municipal or domestic waste. To document this, they have been marked with the following identification:



Because disposal regulations may differ from one country to another within the EU, please contact your supplier if necessary.

## 10 Technical data

### 10.1 Power supply

Power connection	230 V, 50 – 60 Hz 120 V, 60 Hz	
Current consumption	5804/5810 (230 V) 5804/5810 (120 V) 5804 R/5810 R (230 V) 5804 R/5810 R (120 V), 20 A 5804 R/5810 R (120 V), 15 A	6 A 11 A 9 A/10 A 16 A 12 A
Power consumption	5804/5810 (230 V) 5804/5810 (120 V) 5804 R/5810 R (230 V) 5804 R/5810 R (120 V), 20 A 5804 R/5810 R (120 V), 15 A	max. 900 W max. 950 W max. 1650 W max. 1650 W max. 1300 W
EMC: Interference emission (radio interference)	EN 61326-1 Class A	
EMC: Noise immunity	EN 61326	
Overvoltage category	II	
Fuses	5804/5810 (230 V) 5804/5810 (120 V) 5804 R/5810 R (230 V) 5804 R/5810 R (120 V), 20 A 5804 R/5810 R (120 V), 15 A	Excess current switch 12 A Excess current switch 12 A Excess current switch 12 A Excess current switch 18 A Excess current switch 15 A

### 10.2 Ambient conditions

Environment	For indoor use only	
Ambient temperature	5804	2 °C – 35 °C
	5810	2 °C – 40 °C
	5804 R, 5810 R	10 °C – 35 °C
Max. relative humidity	75 %, non-condensing humidity	
Atmospheric pressure	Designed for use up to an altitude of 2000 m above sea level.	
Degree of pollution	2	

**Technical data**

Centrifuge 5804/5804 R/5810/5810 R  
English (EN)

**10.3 Weight/dimensions**

Dimensions (W × D × H)	5804	466 × 550 × 337 mm (18.4 × 21.7 × 13.3 in) Depth of footprint: 496 mm (19.5 in)		
	5804 R	634 × 550 × 342 mm (25.0 × 21.7 × 13.5 in) Depth of footprint: 496 mm (19.5 in)		
	5810	535 × 608 × 345 mm (21.1 × 23.9 × 13.6 in) Depth of footprint: 536 mm (21.1 in)		
	5810 R	700 × 608 × 345 mm (27.6 × 23.9 × 13.6 in) Depth of footprint: 536 mm (21.1 in)		
Weight without rotor	5804	55 kg (121 in)		
	5804 R	80 kg (176 in)		
	5810	68 kg (150 in)		
	5810 R	99 kg (218 in)		
		Rotor		
		A-4-81 (4 × 500 mL)	A-4-44 (4 × 100 mL)	F-34-6-38 (6 × 85 mL)
Noise level	5804	–	< 67 dB(A)	< 51 dB(A)
	5804 R	–	< 56 dB(A)	< 58 dB(A)
	5810	< 65 dB(A)	< 65 dB(A)	< 53 dB(A)
	5810 R	< 56 dB(A)	< 56 dB(A)	< 59 dB(A)

The noise level was measured according to DIN EN ISO 3745 frontally in a sound measuring room with accuracy class 1 at a distance of 1 m from the device and at lab bench height.

## 10.4 Application parameters

Run time	1 – 99 min, adjustable in 1 min increments. infinite (∞)	
Temperature (only 5804 R/5810 R)	-9 °C – 40 °C	
Relative centrifugal force (RCF or rcf)	10 – 20913 × g adjustable up to 3000 × g in 10 × g increments, thereafter in 100 × g increments.	
Rotational speed	200 to 14000 rpm, adjustable up to 5000 rpm in 10 rpm, afterwards in 100 rpm increments.	
Max. load	5804/5804 R 5810/5810 R	4 × 250 mL 4 × 750 mL
Max. kinetic energy	5804/5810 5804 R 5810 R	19000 Nm (11000 rpm) 19000 Nm (11000 rpm) 23000 Nm (12000 rpm)
Inspection obligation in Germany	Yes	
Permitted density of the centrifugate (at max. g-force/rpm and max. load)	1.2 g/mL	
Standardized interface (optional)	RS 232 C	

### Influence of speed on the temperature

Rotational speed	Temperature
11000 rpm	Rotor FA-45-6-30: ≤ 4 °C Rotor F-34-6-38: ≤ 4 °C
Maximum speed	Rotor FA-45-6-30: ≤ 10 °C Rotor F-34-6-38: ≤ 9 °C

### Acceleration and deceleration times (according to DIN 58970)

Tab. 10-1: Approximate acceleration times of the different rotors for the levels 0 to 9 (in seconds) for 230 V devices

5804/ 5804 R	5810/ 5810 R	Rotor	0	1	2	3	4	5	6	7	8	9
-	•	A-4-81	227	198	173	149	132	111	97	85	60	35
-	•	A-4-81- MTP/Flex	223	195	170	147	129	109	95	83	59	33
-	•	A-4-62	222	195	170	148	129	110	96	85	59	27
•	•	A-4-44	373	299	257	215	190	142	106	75	45	20
-	•	A-2-DWP-AT	256	223	191	167	147	126	111	98	72	45
•	•	A-2-DWP	203	176	133	117	100	78	61	45	36	18
•	•	FA-45-6-30	468	378	285	203	179	156	136	103	78	47
•	•	F-34-6-38	467	376	282	199	176	153	132	99	74	36

**Technical data**

Centrifuge 5804/5804 R/5810/5810 R  
English (EN)

5804/ 5804 R	5810/ 5810 R	Rotor	0	1	2	3	4	5	6	7	8	9
•	•	F-45-30-11	282	143	96	73	59	50	44	37	33	19
•	•	F-45-48-PCR	244	123	83	63	51	43	38	32	28	14
•	•	T-60-11	284	145	99	77	63	55	49	43	39	28
-	•	S-4-104 (round bucket)	217	189	166	144	126	108	84	58	43	35
-	•	S-4-104 (plate bucket)	217	189	165	142	125	107	82	55	41	33
•	•	S-4-72	304	247	209	175	154	115	56	29	18	14
•	•	F-35-48-17	704	330	277	233	206	152	72	38	23	17

Tab. 10-2: Approximate deceleration times of the different rotors for the levels 0 to 9 (in seconds) for 230 V devices

5804/ 5804 R	5810/ 5810 R	Rotor	0	1	2	3	4	5	6	7	8	9
-	•	A-4-81	466	203	178	154	137	118	95	86	57	31
-	•	A-4-81- MTP/Flex	513	201	176	154	135	115	94	85	57	30
-	•	A-4-62	477	199	175	151	133	114	95	86	57	26
•	•	A-4-44	282	288	230	201	178	138	90	69	47	21
-	•	A-2-DWP-AT	611	227	197	172	153	130	108	97	66	34
•	•	A-2-DWP	274	182	140	122	105	83	57	45	34	14
•	•	FA-45-6-30	1139	392	296	216	190	167	131	98	80	53
•	•	F-34-6-38	735	385	290	210	184	161	130	97	80	48
•	•	F-45-30-11	317	148	77	54	42	36	27	23	20	18
•	•	F-45-48-PCR	171	128	69	47	36	31	23	20	17	15
•	•	T-60-11	638	295	153	107	85	69	50	43	40	35
-	•	S-4-104 (round bucket)	690	196	173	152	133	114	70	49	38	32
-	•	S-4-104 (plate bucket)	621	196	170	149	131	114	69	48	37	32
•	•	S-4-72	337	242	196	172	152	119	55	32	21	17
•	•	F-35-48-17	310	287	248	214	189	143	73	41	27	16

These values are to be considered as guidelines. Level 9 means "strongest braking", level 0 means "free deceleration". Considerable fluctuations can occur depending upon the condition of the device and the load. The deceleration times for the 230 and 120 V devices are almost identical.



## 10.5 Rotors





Eppendorf centrifuges may only be operated with rotors that are intended for use with the corresponding centrifuge.





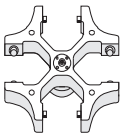

- Only use rotors which bear the name of the centrifuge (e.g. 5804 R).

The Centrifuge 5804/5804 R/5810/5810 R can be operated with the following rotors. Before using sample tubes, please note the recommended manufacturer's specifications with regard to the resistance to centrifugation (max. *g*-force).

### 10.5.1 Rotor A-4-81 (only 5810/5810 R)

















#### 10.5.1.1 Rotor A-4-81 with 500 mL rectangular bucket



			Max. <i>g</i> -force: 3,220 × <i>g</i>
<b>Rotor A-4-81</b>	<b>Rectangular bucket 500 mL</b>	<b>Aerosol-tight cap</b>	Max. speed: 4,000 rpm
Swing-bucket rotor with 4 × 500 mL rectangular buckets			Max. load per bucket (adapter, tube and contents): 780 <i>g</i>

Vessel	Vessel Capacity Vessels per adapter/rotor	Adapters Order no. (international)	Adapter bottom shape Tube diameter Max. tube length with/without aerosol-tight bucket cap	Max. <i>g</i> -force Max. speed Centrifugation radius
	Vessel 1.5/2 mL 20/80	 5810 745.004	flat Ø 11 mm 43 mm/43 mm	2,950 × <i>g</i> 4,000 rpm 16.5 cm
	Blood collection tube 1.2 to 5 mL 20/80	 5810 746.000	flat Ø 11 mm 108 mm/108 mm	3,000 × <i>g</i> 4,000 rpm 16.8 cm
	Vessel 2.6 to 5 mL 25/100	 5810 720.001	flat Ø 13 mm 107 mm/108 mm	3,000 × <i>g</i> 4,000 rpm 16.8 cm

## Technical data



Centrifuge 5804/5804 R/5810/5810 R  
English (EN)

Vessel	Vessel Capacity Vessels per adapter/rotor	Adapters  Order no. (international)	Adapter bottom shape Tube diameter Max. tube length with/ without aerosol-tight bucket cap	Max. g-force Max. speed Centrifugation radius
	Vessel 2.6 to 7 mL 18/72	 5810 747.007	flat Ø 13 mm 108 mm/108 mm	3,000 × g 4,000 rpm 16.8 cm
	Blood collection tube 3 to 15 mL 16/64	 5810 748.003	flat Ø 16 mm 108 mm/108 mm	3,000 × g 4,000 rpm 16.8 cm
	Vessel 7 to 17 mL 16/64	 5810 721.008	flat Ø 17.5 mm 118 mm/118 mm	3,000 × g 4,000 rpm 16.8 cm
	Conical tube 15 mL 12/48	 5810 722.004	conical Ø 17.5 mm 119 mm/121 mm	3,100 × g 4,000 rpm 17.3 cm
	Conical tube 50 mL 5/20	 5810 723.000	conical Ø 31 mm 116 mm/122 mm	3,100 × g 4,000 rpm 17.3 cm
	Centriprep 50 mL 5/20	 5810 739.004	flat Ø 31 mm -/121 mm	3,100 × g 4,000 rpm 17.3 cm
	Conical tube, skirted 50 mL 5/20	 5810 739.004  5804 737.008	flat Ø 31 mm -/119 mm	3,100 × g 4,000 rpm 17.3 cm
	Bottles 180 to 250 mL 1/4	 5825 722.000	flat Ø 62 mm -/133 mm	3,100 × g 4,000 rpm 17.3 cm

Vessel	Vessel Capacity Vessels per adapter/rotor	Adapters Order no. (international)	Adapter bottom shape Tube diameter Max. tube length with/without aerosol-tight bucket cap	Max. g-force Max. speed Centrifugation radius
	Wide-neck bottle 400 mL 1/4	 5810 728.002	flat Ø 81 mm -/133 mm	3,220 × g 4,000 rpm 18.0 cm
	Wide-neck bottle, rectangular 500 mL -/4	-	flat 83 mm 134 mm/134 mm	3,220 × g 4,000 rpm 18.0 cm

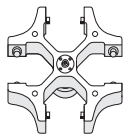
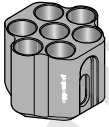
### 10.5.1.2 Rotor A-4-81 with conical tubes

		Max. g-force:	3,220 × g
<b>Rotor A-4-81</b>	<b>Bucket for 7 × 50 mL conical tubes</b>	Max. speed:	4,000 rpm
Swing-bucket rotor with 4 buckets for conical tubes		Max. load per bucket (adapter, tube and contents):	7 × 75 g





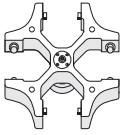
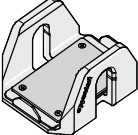

Vessel	Vessel Capacity Vessels per adapter/rotor	Adapters Order no. (international)	Bottom shape Tube diameter Max. tube length	Max. g-force Max. speed Centrifugation radius
	Conical tube 15 mL 7/28	 5820 718.005	conical Ø 17.5 mm 120 mm	3,184 × g 4,000 rpm 17.8 cm
	Conical tube 50 mL 7/28	-	conical Ø 30 mm 117 mm	3,220 × g 4,000 rpm 18.0 cm

## Technical data

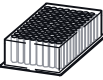
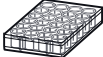
Centrifuge 5804/5804 R/5810/5810 R  
English (EN)

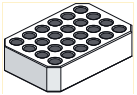
## 10.5.1.3 Rotor A-4-81 with MTP/Flex bucket

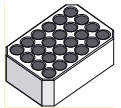
		Max. g-force: $2,900 \times g$
<b>Rotor A-4-81</b> Swing-bucket rotor with 4 MTP/Flex carriers	<b>MTP/Flex buckets</b>	Max. speed: 4,000 rpm Max. load per bucket (adapter, plate and contents): 380 g

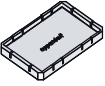
Vessel	Plate Capacity Plates, rack or glass slides per adapter/rotor	Adapters  Order no. (international)	Bottom shape		Max. g-force Max. speed Centrifugation radius
			Tube diameter	Max. loading height	
	Micro test plate 96/384 wells 4/16	-	flat - 60 mm		$2,900 \times g$ 4,000 rpm 16.3 cm
	Deepwell plate 96 wells 1/4	-	flat - 60 mm		$2,900 \times g$ 4,000 rpm 16.3 cm
	Cell culture plate  2/8	-	flat - 60 mm		$2,900 \times g$ 4,000 rpm 16.3 cm
	Kit  1/4	-	flat - 60 mm		$2,900 \times g$ 4,000 rpm 16.3 cm
	Tube in IsoRack 24 x 0.5 mL 1/4	 5825 708.008	flat Ø 6 mm 60 mm		$2,700 \times g$ 4,000 rpm 15.0 cm
	Tube in IsoRack 24 x 1.5/2 mL 1/4	 5825 709.004	flat Ø 11 mm 60 mm		$2,600 \times g$ 4,000 rpm 14.6 cm
	384-well PCR plate  1/4	 5825 713.001	flat - 60 mm		$2,700 \times g$ 4,000 rpm 15.8 cm

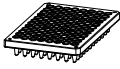
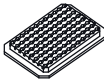
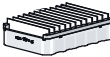
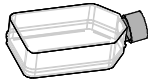
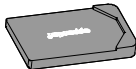

Vessel	Plate Capacity Plates, rack or glass slides per adapter/rotor	Adapters  Order no. (international)	Bottom shape Tube diameter Max. loading height	Max. g-force Max. speed Centrifugation radius
	96-well PCR plate  1/4	 5825 711.009	flat - 60 mm	2,600 × g 4,000 rpm 16.1 cm
Slides	CombiSlide 12 slides 12/48	 5825 706.005	flat - 60 mm	1,000 × g 2,372 rpm 15.9 cm
	Cell culture bottle with/without filter  75 cm <sup>2</sup> : Sarstedt 83.1811.002/ 83.1811 25 cm <sup>2</sup> : Sarstedt 83.1810.002/ 83.1810 Greiner Bio-One 690175/690160 TPP 90026/90025 IWAKI 3102-025  1/4	 5825 719.000	flat -  60 mm	1,000 × g  2,501 rpm  14.3 cm







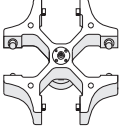





## Technical data

















Centrifuge 5804/5804 R/5810/5810 R  
English (EN)

## 10.5.2 Rotor A-4-62 and A-4-62-MTP (only 5810/5810 R)

## 10.5.2.1 Rotor A-4-62 with 250 mL rectangular bucket



			Max. <i>g</i> -force: 3,220 × <i>g</i>
<b>Rotor A-4-62</b>	<b>Rectangular bucket 250 mL</b>	<b>Aerosol-tight cap</b>	Max. speed: 4,000 rpm
Swing-bucket rotor with 4 × 250 mL rectangular buckets			Max. load per bucket (adapter, tube and contents): 620 g

Vessel	Vessel Capacity Vessels per adapter/rotor	Adapters Order no. (international)	Adapter bottom shape Tube diameter Max. tube length with/without aerosol-tight bucket cap	Max. <i>g</i> -force Max. speed Centrifugation radius
	Vessel 1.5/2 mL 16/64	 5810 751.004	flat Ø 11 mm 43 mm/43 mm	3,000 × <i>g</i> 4,000 rpm 17.1 cm
	Vessels 1.2 to 5 mL 25/100	 5810 750.008	flat Ø 11 mm 115 mm/123 mm	3,050 × <i>g</i> 4,000 rpm 17.3 cm
	Vessels 2.6 to 7 mL 15/60	 5810 752.000	flat Ø 13 mm 118 mm/121 mm	3,050 × <i>g</i> 4,000 rpm 17.3 cm
	Vessels 3 to 15 mL 12/48	 5810 753.007	flat Ø 16 mm 116 mm/121 mm	3,050 × <i>g</i> 4,000 rpm 17.3 cm
	Vessels 7 to 17 mL 12/48	 5810 754.003	flat Ø 17.5 mm 114 mm/118 mm	3,050 × <i>g</i> 4,000 rpm 17.3 cm
	Conical tube 15 mL 9/36	 5810 755.000	conical Ø 17.5 mm 121 mm/127 mm	3,150 × <i>g</i> 4,000 rpm 17.8 cm

Vessel	Vessel Capacity Vessels per adapter/rotor	Adapters Order no. (international)	Adapter bottom shape Tube diameter Max. tube length with/ without aerosol-tight bucket cap	Max. <i>g</i> -force Max. speed Centrifugation radius
	Vessel 7 to 18 mL 8/32	 5810 756.006	flat Ø 20 mm 119 mm/126 mm	3,050 × <i>g</i> 4,000 rpm 17.3 cm
	Vessel 18 to 30 mL 4/16	 5810 757.002	flat Ø 26 mm 116 mm/119 mm	3,050 × <i>g</i> 4,000 rpm 17.3 cm
	Conical tube 50 mL 3/12	 5810 758.009	conical Ø 31 mm 116 mm/122 mm	3,150 × <i>g</i> 4,000 rpm 17.8 cm
	Conical tube 50 mL 4/16	 5810 763.002	conical Ø 31 mm -/122 mm	3,050 × <i>g</i> 4,000 rpm 17.3 cm
	Vessel 30 to 50 mL 4/16	 5810 759.005	flat Ø 31 mm -/119 mm	3,050 × <i>g</i> 4,000 rpm 17.3 cm
	Conical tube, skirted 50 mL 4/16	 5810 759.005  5804 737.008	flat Ø 31 mm -/119 mm	3,050 × <i>g</i> 4,000 rpm 17.3 cm
	Vessel 50 to 75 mL 2/8	 5810 760.003	flat Ø 35 mm 118/122 mm	3,050 × <i>g</i> 4,000 rpm 17.3 cm
	Vessel 80 to 120 mL 1/4	 5810 761.000	flat Ø 45 mm 125/138 mm	3,050 × <i>g</i> 4,000 rpm 17.3 cm

**Technical data**

Centrifuge 5804/5804 R/5810/5810 R  
English (EN)

Vessel	Vessel Capacity Vessels per adapter/rotor	Adapters  Order no. (international)	Adapter bottom shape Tube diameter Max. tube length with/ without aerosol-tight bucket cap	Max. <i>g</i> -force Max. speed Centrifugation radius
	Bottles 180 to 250 mL 1/4	 5810 770.009	flat Ø 62 mm 127/136 mm	3,220 × <i>g</i> 4,000 rpm 18.0 cm

DOMINIQUE DUTSCHER



### 10.5.2.2 Rotor A-4-62 with MTP bucket



		Max. g-force: $2,750 \times g$
<b>Rotor A-4-62</b>	<b>MTP buckets</b>	Max. speed: 4,000 rpm
Swing-bucket rotor with 4 MTP buckets		Max. load per bucket (adapter, plate and contents) 380 g







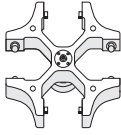
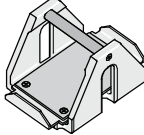
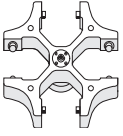
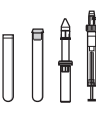





Plate	Plate Capacity Plates or glass slides per adapter/rotor	Adapters Order no. (international)	Bottom shape Max. loading height	Max. g-force Max. speed Centrifugation radius
	Micro test plate 96/384 wells 4/16		flat 53 mm	$2,750 \times g$ 4,000 rpm 15.4 cm
	Deepwell plate 96/384 wells 1/4		flat 53 mm	$2,750 \times g$ 4,000 rpm 15.4 cm
	Cell culture plate 2/8		flat 53 mm	$2,750 \times g$ 4,000 rpm 15.4 cm
	384-well PCR plate 1/4	 5825 713.001	flat 53 mm	$2,700 \times g$ 4,000 rpm 14.9 cm
	96-well PCR plate 1/4	 5825 711.009	flat 53 mm	$2,600 \times g$ 4,000 rpm 15.2 cm
Slides	CombiSlide 12 slides 12/48	 5825 706.005	flat 53 mm	$1,000 \times g$ 2,442 rpm 15.0 cm















## Technical data

Centrifuge 5804/5804 R/5810/5810 R  
English (EN)

## 10.5.3 Rotor A-4-44

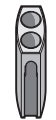





			Max. g-force: $4,400 \times g$
<b>Rotor A-4-44</b>	<b>Rectangular bucket 100 mL</b>	<b>Aerosol-tight cap</b>	Max. speed: 5,000 rpm
Swing-bucket rotor with 4 × 100 mL rectangular buckets			Max. load per bucket (adapter, tube and contents): 310 g

Vessel	Vessel Capacity Vessels per adapter/rotor	Adapters Order no. (international)	Adapter bottom shape Tube diameter Max. tube length with/without aerosol-tight bucket cap	Max. g-force Max. speed Centrifugation radius
	Vessel 1.5/2 mL 12/48	 5804 751.000	flat Ø 11 mm 43 mm/43 mm	$4,100 \times g$ 5,000 rpm 14.8 cm
	Vessels 1.2 to 5 mL 14/56	 5804 750.004	flat Ø 11 mm 102 mm/105 mm	$4,200 \times g$ 5,000 rpm 15.0 cm
	Vessels 2.6 to 7 mL 9/36	 5804 752.007	flat Ø 13 mm 106 mm/108 mm	$4,200 \times g$ 5,000 rpm 15.0 cm
	Vessels 3 to 15 mL 7/28	 5804 753.003	flat Ø 16 mm 106 mm/108 mm	$4,200 \times g$ 5,000 rpm 15.0 cm
	Vessels 7 to 17 mL 6/24	 5804 754.000	flat Ø 17.5 mm 106 mm/110 mm	$4,200 \times g$ 5,000 rpm 15.0 cm
	Conical tube 15 mL 4/16	 5804 755.006	conical Ø 17.5 mm -/121 mm	$4,300 \times g$ 5,000 rpm 15.5 cm

Vessel	Vessel Capacity Vessels per adapter/rotor	Adapters Order no. (international)	Adapter bottom shape Tube diameter Max. tube length with/without aerosol-tight bucket cap	Max. g-force Max. speed Centrifugation radius
	Conical tube 15 mL 2/8	 5804 717.007	conical Ø 17.5 mm 121 mm/121 mm	4,400 × g 5,000 rpm 15.7 cm
	Vessel 7 to 18 mL 4/16	 5804 756.002	flat Ø 20 mm 104 mm/107 mm	4,200 × g 5,000 rpm 15.0 cm
	Vessel 18 to 30 mL 2/8	 5804 757.009	flat Ø 26 mm 100 mm/110 mm	4,200 × g 5,000 rpm 15.0 cm
	Conical tube 50 mL 1/4	 5804 758.005	conical Ø 31 mm -/122 mm	4,300 × g 5,000 rpm 15.5 cm
	Conical tube 50 mL 1/4	 5804 718.003	conical Ø 31 mm 119 mm/122 mm	4,400 × g 5,000 rpm 15.7 cm
	Conical tube 50 mL -/8	 5804 706.005  Max. load 144 g (insert, tubes and contents)	flat with conical insert - -/120 mm	4,500 × g 5,000 rpm 16.1 cm
	Vessel 30 to 50 mL 1/4	 5804 759.001	flat Ø 31 mm 108 mm/122 mm	4,200 × g 5,000 rpm 15.0 cm

## Technical data

Centrifuge 5804/5804 R/5810/5810 R  
English (EN)

Vessel	Vessel Capacity Vessels per adapter/rotor	Adapters Order no. (international)	Adapter bottom shape Tube diameter Max. tube length with/ without aerosol-tight bucket cap	Max. g-force Max. speed Centrifugation radius
	Conical tube, skirted 50 mL 1/4	 5804 759.001  5804 737.008	flat Ø 31 mm 108 mm/122 mm	4,200 × <i>g</i> 5,000 rpm 15.0 cm
	Vessel 50 to 75 mL 1/4	 5804 760.000	flat Ø 35 mm 108 mm/119 mm	4,200 × <i>g</i> 5,000 rpm 15.0 cm
	Vessel 80 to 100 mL 1/4	 5804 761.006	flat Ø 45 mm 100 mm/114 mm	4,200 × <i>g</i> 5,000 rpm 15.0 cm

### 10.5.4 Rotor A-2-DWP-AT (only 5810/5810 R)









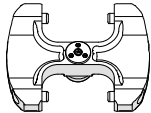
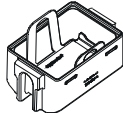
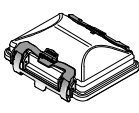

			Max. <i>g</i> force:	3486 × <i>g</i>
<b>Rotor A-2-DWP-AT</b>	<b>Bucket</b>	<b>Aerosol-tight cap</b>	Max. speed:	4500 rpm
Swing-bucket rotor with 2 aerosol-tight buckets (always use with a plate carrier)			Max. load per bucket (adapter, plate and contents):	500 g

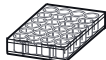
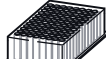
Plate	Plate Capacity Plate/ slide per adapter/rotor	Adapter Order no. (international)	Adapter bottom shape Max. loading height	Max. <i>g</i> force Max. speed Centrifugation radius
	Microplate 96/384 wells 4/16	-	60 mm	3486 × <i>g</i> 4500 rpm 154 mm
	Cell-culture plate 2/8	-	60 mm	3486 × <i>g</i> 4500 rpm 154 mm
	Deepwell plate 96 mL 1/4	-	Flat 67 mm	3486 × <i>g</i> 4500 rpm 154 mm
	Kit 1/4	-	60 mm	3486 × <i>g</i> 4500 rpm 154 mm
	IsoRack 24 × 0.5 mL micro test tubes 1/4		Open Ø 6 mm 60 mm	2500 × <i>g</i> 3900 rpm 147 mm
	IsoRack 24 × 1.5/2.0 mL micro test tubes 1/4		Open Ø 11 mm 60 mm	2432 × <i>g</i> 3900 rpm 143 mm
	PCR plate 384 wells 1/4	 5825 713.001	60 mm	3373 × <i>g</i> 4500 rpm 149 mm

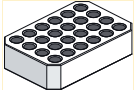
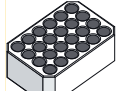
**Technical data**

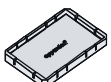
Centrifuge 5804/5804 R/5810/5810 R  
English (EN)

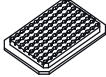
Plate	Plate Capacity Plate/ slide per adapter/rotor	Adapter Order no. (international)	Adapter bottom shape Max. loading height	Max. <i>g</i> force Max. speed Centrifugation radius
	PCR plate 96 wells 1/4	 5825 711.009	60 mm	3486 × <i>g</i> 4500 rpm 154 mm
Slide	CombiSlide 8 slides 8/16	 5825 706.005	Flat 60 mm	100 × <i>g</i> 772 rpm 150 mm

DOMINIQUE DUTSCHER

### 10.5.5 A-2-DWP rotor

 Check the load if using two fully loaded DWP plates.









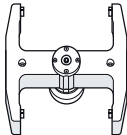
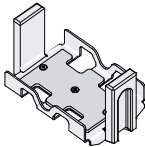
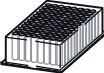
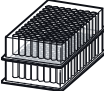

		Max. g-force:	2,250 × g
<b>A-2-DWP rotor</b>	<b>Deepwell plate bucket</b>	Max. speed:	3,700 rpm
Swing-bucket rotor with 2 Deepwell plate buckets		Max. load per bucket (adapter, plate and contents):	380 g

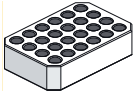
Plate	Plate Capacity Plates/slides per adapter/rotor	Adapters Order no. (international)	Adapter bottom shape Max. loading height	Max. g-force Max. speed Centrifugation radius
	Micro test plate 96/384 wells 4/8	SBS adapter* 5825 718.003	flat 89 mm	2,250 × g 3,700 rpm 14.7 cm
	Cell culture plate 4/8	SBS adapter* 5825 718.003	flat 89 mm	2,250 × g 3,700 rpm 14.7 cm
	Deepwell plate 96 wells 2/4	SBS adapter* 5825 718.003	flat 89 mm	2,250 × g 3,700 rpm 14.7 cm
	Kit 1/2	SBS adapter* 5825 718.003	flat 89 mm	2,250 × g 3,700 rpm 14.7 cm
	Tube in IsoRack 24 x 0.5 mL 1/2	 5825 708.008	flat Ø 6 mm 89 mm	2,050 × g 3,700 rpm 13.8 cm
	Tube in IsoRack 24 x 1.5/2 mL 1/2	 5825 709.004	flat Ø 11 mm 89 mm	1,990 × g 3,700 rpm 13.3 cm
	384-well PCR plate 1/2	 5825 713.001	flat 89 mm	2,170 × g 3,700 rpm 14.2 cm

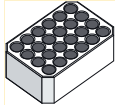
**Technical data**

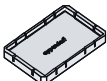
Centrifuge 5804/5804 R/5810/5810 R  
English (EN)

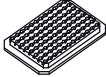







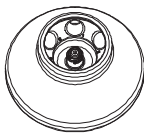

Plate	Plate Capacity Plates/slides per adapter/rotor	Adapters Order no. (international)	Adapter bottom shape Max. loading height	Max. g-force Max. speed Centrifugation radius
	96-well PCR plate  1/2	  5825 711.009	flat  89 mm	2,220 × g 3,700 rpm 14.5 cm
Slides	CombiSlide 8 slides 8/16	  5825 706.005	flat  60 mm	100 × g 791 rpm 14.3 cm

\*) Optional. Secures the plate against slipping.













### 10.5.6 Rotor FA-45-6-30

	Max. g-force: $16,639 \times g$ (5810 R: $20,133 \times g$ )
	Max. speed: 11,000 rpm (5810 R: 12,100 rpm)
<b>Rotor FA-45-6-30</b> Fixed-angle rotor for 6 conical tubes	Max. load (adapter, tube and contents): $6 \times 75 g$

Vessel	Vessel  Capacity  Vessels per adapter/rotor	Adapters  Order no. (international)	Adapter bottom shape  Tube diameter  Max. tube length with rotor lid	Max. g-force at 11,000 rpm (5804/5804 R/5810)  Max. g-force at 12,100 rpm (5810 R)  Centrifugation radius
	Conical tube 15 mL 1/6	 5820 717.009	conical Ø 17 mm 125 mm	$16,233 \times g$ $19,642 \times g$ 12.0 cm
	Conical tube 50 mL 1/6	-	conical Ø 30 mm 127 mm	$16,639 \times g$ $20,133 \times g$ 12.3 cm
	Oak Ridge 16 mL 1/6	 5820 720.000	Round Ø 18.1 mm 107 mm	$16,233 \times g$ $19,642 \times g$ 12.0 cm
	Oak Ridge 30 mL 1/6	 5820 721.006	Round Ø 25.7 mm 104 mm	$14,204 \times g$ $17,187 \times g$ 10.5 cm
	Oak Ridge 35 mL 1/6	 5820 722.002	conical Ø 28.7 mm 113 mm	$15,151 \times g$ $18,333 \times g$ 11.2 cm
	Vessel 5 mL 1/6	 5820 730.005	conical Ø 17 mm -	$16,369 \times g$ $19,806 \times g$ 12.1 cm

## Technical data

Centrifuge 5804/5804 R/5810/5810 R  
English (EN)









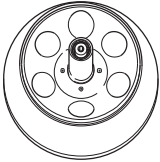

Vessel	Vessel  Capacity  Vessels per adapter/rotor	Adapters  Order no. (international)	Adapter bottom shape  Tube diameter  Max. tube length with rotor lid	Max. g-force at 11,000 rpm (5804/5804 R/ 5810)  Max. g-force at 12,100 rpm (5810 R)  Centrifugation radius
	Vessel 2,6 to 5 mL 1/6	  5820 726.008	Round Ø 13,5 mm -	16,233 x g 19,246 x g 12.0 cm
	Vessel 4 to 8 mL 1/6	  5820 725.001	Round Ø 13,5 mm 119 mm	16,233 x g 19,246 x g 12.0 cm
	Vessel 5.5 mL – 10 mL 1/6	  5820 728.000	Round Ø 16 mm -	16,233 x g 19,246 x g 12.0 cm
	Vessel 7.5 to 12 mL 1/6	  5820 727.004	Round Ø 16.4 mm 119 mm	16,233 x g 19,246 x g 12.0 cm
	Vessel 9 mL 1/6	  5820 729.007	Round Ø 16.4 mm 112 mm	16,233 x g 19,246 x g 12.0 cm



- ▶ Do not use Corning® 50 mL PET Centrifuge Tubes in the rotor FA-45-6-30. These tubes may remain stuck in the bore holes after centrifugation.











### 10.5.7 Rotor F-34-6-38

	Max. g-force: 15,557 × g (5810 R: 18,514 × g)
	Max. speed: 11 000 rpm (5810 R: 12 000 rpm)
<b>Rotor F-34-6-38</b> Fixed-angle rotor for 6 × 85 mL tubes	Max. load (adapter, tube and contents): 6 × 125 g

Vessel	Vessel  Capacity  Vessels per adapter/rotor	Adapter  Order no. (international)	Adapter bottom shape  Tube diameter  Max. tube length with rotor lid	Max. g-force at 11 000 rpm (5804/5804 R/5810)  Max. g-force at 12 000 rpm (5810 R)  Centrifugation radius
	Micro test tube 1.5/2 mL 4/24	 5804 770.005	Round Ø 11 mm 43 mm	15 300 × g 18 200 × g 11.3 cm
	Micro test tube 5 mL 1/6	 5804 777.000	Conical Ø 17 mm -	14 150 × g 16 842 × g 10.45 cm
	Blood collection tube 2 mL to 5 mL 3/18	 5804 738.004	Round Ø 13 mm 80 mm	14 339 × g 17 065 × g 10.6 cm
	Blood collection tube 4 mL to 7 mL 3/18	 5804 739.000	Round Ø 13 mm 107 mm	15 442 × g 18 353 × g 11.4 cm
	Vessel 7 mL to 15 mL 2/12	 5804 771.001	Round Ø 16 mm 112 mm	15 150 × g 18 000 × g 11.2 cm









## Technical data

Centrifuge 5804/5804 R/5810/5810 R  
English (EN)

Vessel	Vessel  Capacity  Vessels per adapter/rotor	Adapter  Order no. (international)	Adapter bottom shape  Tube diameter  Max. tube length with rotor lid	Max. g-force at 11000 rpm (5804/5804 R/ 5810)  Max. g-force at 12000 rpm (5810 R)  Centrifugation radius
	Conical tube 15 mL 1/6	 5804 776.003	Conical Ø 17.5 mm 123 mm	14450 × g 17200 × g 10.7 cm
	Vessel 15 mL to 18 mL 1/6	 5804 772.008	Round Ø 18 mm 123 mm	14750 × g 17550 × g 10.9 cm
	Vessel 20 mL to 30 mL 1/6	 5804 773.004	Round Ø 26 mm 123 mm	14900 × g 17700 × g 11.0 cm
	Vessel 50 mL 1/6	 5804 774.000	Round Ø 29 mm 123 mm	15157 × g 18014 × g 11.2 cm
	Conical tube 50 mL 1/6	 5804 775.007	Conical Ø 29.5 mm 121 mm	14600 × g 17400 × g 10.8 cm
	Vessel 85 mL -/6	-	- Ø 38 mm 121 mm	15550 × g 18500 × g 11.5 cm

### 10.5.8 Rotor FA-45-30-11 and F-45-30-11

	Max. g-force:	20,817 × g
<b>Rotor FA-45-30-11</b> Aerosol-tight fixed-angle rotor for 30 tubes	Max. speed:	14,000 rpm
<b>Rotor F-45-30-11</b> Fixed-angle rotor for 30 tubes	Max. load (adapter, tube and contents):	30 × 3.5 g



Vessel	Vessel Capacity Vessels per adapter/rotor	Adapters Order no. (international)	Adapter bottom shape Tube diameter	Max. g-force Max. speed Centrifugation radius
	Vessel 1.5/2 mL -/30	-	- Ø 11 mm	20,817 × g 14,000 rpm 9.5 cm
	PCR tube 0.2 mL 1/30	 5425 715.005	conical Ø 6 mm	16,200 × g 14,000 rpm 7.4 cm
	Vessel 0.4 mL 1/30	 5425 717.008	conical Ø 6 mm	20,817 × g 14,000 rpm 9.5 cm
	Vessel 0.5 mL 1/30	 5425 716.001	- Ø 8 mm	18,400 × g 14,000 rpm 8.4 cm
	Microtainers 0.6 mL 1/30	 5425 716.001	- Ø 8 mm	20,817 × g 14,000 rpm 9.5 cm

## Technical data

Centrifuge 5804/5804 R/5810/5810 R  
English (EN)



## 10.5.9 Rotor F-45-48-PCR

	Max. g-force:	15,294 × g
	Max. speed:	12,000 rpm
<b>Rotor F-45-48-PCR</b> Fixed-angle rotor for tube strips or 0.2 mL PCR tubes	Max. load (tube and contents):	6 × 3.5 g



Vessel	Vessel Capacity Vessels per adapter/rotor	Adapters	Tube diameter	Max. g-force Max. speed Centrifugation radius
	8-tube/5-tube tube strips 8/5 × 0,2 mL -/6 × 8 and/or -/ 6 × 5	-	Ø 6 mm	15,294 × g 12,000 rpm 9.5 cm
	Vessel 0.2 mL -/48	-	Ø 6 mm	15,294 × g 12,000 rpm 9.5 cm







## 10.5.10 Rotor T-60-11

	<b>Rotor T-60-11</b> Drum rotor for tubes	Max. g-force:	14,000 × g
		Max. speed:	16.435 rpm
		Max. load (tube and contents):	6 × 70 g

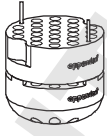
Vessel	Vessel Capacity Vessels per adapter/rotor	Adapters	Tube diameter	Max. g-force Max. speed Centrifugation radius
	Vessel 1.5/2 mL 10/60	-	Ø 11 mm	16,435 × g 14,000 rpm 7.5 cm
	Vessel 0.4 mL 20/120	-	Ø 6 mm	16,435 × g 14,000 rpm 7.5 cm



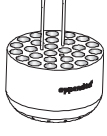

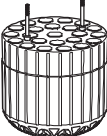



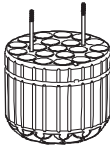

### 10.5.11 Rotor S-4-104 (only 5810/5810 R)

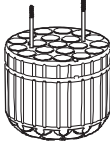
			Max. <i>g</i> force:	3214 × <i>g</i>
<b>Rotor S-4-104</b>	<b>Round bucket 750 mL</b>	<b>Aerosol-tight cap</b>	Max. speed:	3900 rpm
Swing-bucket rotor with 4 × 750 mL round buckets			Max. load per bucket (adapter, tube and contents):	1000 <i>g</i>



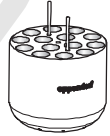

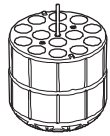

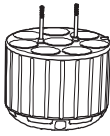

Vessel	Vessel Capacity Vessels per adapter/rotor	Adapter Order no. (international)	Adapter bottom shape Tube diameter Max. tube length with/ without aerosol-tight bucket cap	Max. <i>g</i> force Max. speed Centrifugation radius
	Micro test tube 1.5/2 mL 50/200	 5825 740.009	Open Ø 11 mm 39 mm	3197 × <i>g</i> 3900 rpm 18.8 cm
	Micro test tube 5 mL 14/56	 5825 734.009 (without upper part)	Conical Ø 17 mm 60 mm	3197 × <i>g</i> 3900 rpm 18.8 cm
	Dish-bottomed vessel Ø 12 mm × 75 mm 27/108	 5825 747.003	Round Ø 12 mm 108 mm/115 mm	3112 × <i>g</i> 3900 rpm 18.3 cm
	Vessel 4 mL to 8 mL 23/92	 5825 738.004	Round Ø 13 mm × 100 mm 108 mm/115 mm	3044 × <i>g</i> 3900 rpm 17.9 cm

## Technical data

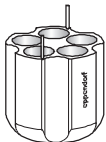
Centrifuge 5804/5804 R/5810/5810 R  
English (EN)

Vessel	Vessel Capacity Vessels per adapter/rotor	Adapter Order no. (international)	Adapter bottom shape Tube diameter Max. tube length with/ without aerosol-tight bucket cap	Max. <i>g</i> force Max. speed Centrifugation radius
	Vessel 7.5 mL to 12 mL 20/80	 5825 736.001	Round Ø 16 mm × 98 mm 114 mm/119 mm	3061 × <i>g</i> 3900 rpm 18 cm
	Vessel 8 mL to 16 mL 7/28 (Load inner bores only (Fig. 5-5 on p. 32))	 5825 736.001	Round Ø 16 mm (Do not use the aerosol-tight cap.)/ 125 mm	3061 × <i>g</i> 3900 rpm 18 cm
	Vessel 9 mL 20/80	 5825 743.008	Round Ø 17.5 mm × 100 mm 106 mm/111 mm	3044 × <i>g</i> 3900 rpm 17.9 cm
	Dish-bottomed vessel 14 mL 14/56	 5825 748.000	Round Ø 17.5 mm 112 mm/117 mm	3146 × <i>g</i> 3900 rpm 18.5 cm
	Conical tube 15 mL 14/56	 5825 734.009	Conical Ø 17 mm × 104 mm 120 mm/125 mm	3197 × <i>g</i> 3900 rpm 18.8 cm
	Universal vessel 30 mL  8/32	 5825 755.006	Flat Ø 25 mm  106 mm/111 mm	3900 × <i>g</i> 3900 rpm  17.4 cm

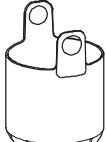

Vessel	Vessel Capacity Vessels per adapter/rotor	Adapter Order no. (international)	Adapter bottom shape Tube diameter Max. tube length with/ without aerosol-tight bucket cap	Max. <i>g</i> force Max. speed Centrifugation radius
	Conical tube 50 mL 7/28	 5825 733.002	Conical Ø 29 mm × 109 mm 116 mm/122 mm	3180 × <i>g</i> 3900 rpm 18.7 cm
	Conical tube, skirted 50 mL 5/20	 5825 732.006	Conical Ø 29 mm × 104 mm 116 mm/120 mm	3027 × <i>g</i> 3900 rpm 17.8 cm
	Centrifuge bottle 175 mL - 250 mL 1/4	 5825 741.005	Flat Ø 62 mm × 129 mm 125 mm/145 mm	3112 × <i>g</i> 3900 rpm 18.3 cm
	Wide-neck bottle 750 mL 1/4	 5825 744.004	Flat Ø 102 mm × 132 mm (Do not use the aerosol-tight cap.)/ 140 mm	3146 × <i>g</i> 3900 rpm 18.5 cm
	Corning centrifuge bottle 500 mL 1/4	 5825 745.000	Conical Ø 96 mm (Do not use the aerosol-tight cap.)/ 147 mm	3146 × <i>g</i> 3900 rpm 18.7 cm



**NOTICE! Buckets swinging out in the wrong direction.**

If the wrong adapters are used for 500 mL corning vessels, it might happen that the buckets of the swing-bucket rotor swing out in the wrong direction. This can lead to sample loss or damage of the centrifuge.

- Therefore, only use the Eppendorf adapters for 500 mL corning vessels intended for this purpose.



Do not use an aerosol-tight bucket cap with Corning 50 mL conical tubes.

## Technical data

Centrifuge 5804/5804 R/5810/5810 R  
English (EN)



			Max. g-force: 2568 × g
<b>Rotor S-4-104</b>	<b>Plate bucket</b>	<b>Aerosol-tight cap</b>	Max. speed: 3900 rpm
Swing-bucket rotor with 4 × plate buckets (always use with a plate carrier and a bottom element)			Max. load per bucket (plate carrier, bottom element, plate and contents): 530 g

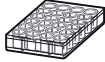
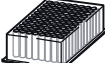

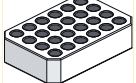

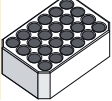

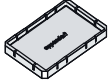

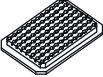

Plate	Plate Capacity Plates/slides per adapter/rotor	Adapter Order no. (international)	Adapter bottom shape Max. loading height	Max. g force Max. speed Centrifugation radius
	Microplate 96/384 wells 4/16	–	Flat – 47 mm/60 mm	2568 × g 3900 rpm 15.1 cm
	Cell-culture plate 2/8	–	Flat – 47 mm/60 mm	2568 × g 3900 rpm 15.1 cm
	Deepwell plate 96 wells 1/4	–	Flat – 47 mm/60 mm	2568 × g 3900 rpm 15.1 cm
	Kit 1/4	–	Flat – 47 mm/60 mm	2568 × g 3900 rpm 15.1 cm
	IsoRack 24 × 0.5 mL micro test tubes 1/4	 5825 708.008	Open Ø 6 mm 47 mm/60 mm	2449 × g 3900 rpm 14.4 cm
	IsoRack 24 × 1.5/2 mL micro test tubes 1/4	 5825 709.004	Open Ø 11 mm 47 mm/60 mm	2381 × g 3900 rpm 14.0 cm
	PCR plate 384 wells 1/4	 5825 713.001	Flat 47 mm/60 mm	2415 × g 3900 rpm 14.2 cm

Plate	Plate Capacity Plates/slides per adapter/rotor	Adapter Order no. (international)	Adapter bottom shape Max. loading height	Max. g force Max. speed Centrifugation radius
	PCR plate 96 wells 1/2	 5825 711.009	Conical 47 mm/60 mm	2449 × g 3900 rpm 14.4 cm
Slide	CombiSlide 12 slides 12/48	 5825 706.005	Flat 47 mm/60 mm	1000 × g 2467 rpm 14.7 cm

DOMINIQUE DUTSCHER

## Technical data

Centrifuge 5804/5804 R/5810/5810 R  
English (EN)



		Max. g-force:	2568 × g
<b>Rotor S-4-104</b>	<b>Plate bucket</b> (always use with a plate carrier)	Max. speed:	3900 rpm
Swing-bucket rotor with 4 × plate buckets		Max. load per bucket (adapter, plate and contents):	450 g

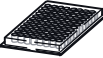
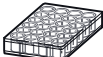
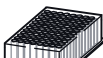
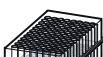

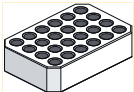

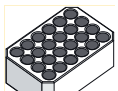

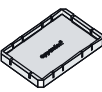

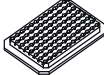

Plate	Plate Capacity Plates/slides per adapter/rotor	Adapter Order no. (international)	Adapter bottom shape Max. loading height	Max. g force Max. speed Centrifugation radius
	Microplate 96/384 wells 4/16	–	Flat – 47 mm/60 mm	2568 × g 3900 rpm 15.1 cm
	Cell-culture plate 2/8	–	Flat – 47 mm/60 mm	2568 × g 3900 rpm 15.1 cm
	Deepwell plate 96 wells 1/4	–	Flat – 47 mm/60 mm	2568 × g 3900 rpm 15.1 cm
	Kit 1/4	–	Flat – 47 mm/60 mm	2568 × g 3900 rpm 15.1 cm
	IsoRack 24 × 0.5 mL micro test tubes 1/4	 5825 708.008	Open Ø 6 mm 47 mm/60 mm	2449 × g 3900 rpm 14.4 cm
	IsoRack 24 × 1.5/2 mL micro test tubes 1/4	 5825 709.004	Open Ø 11 mm 47 mm/60 mm	2381 × g 3900 rpm 14.0 cm
	PCR plate 384 wells 1/4	 5825 713.001	Flat 47 mm/60 mm	2415 × g 3900 rpm 14.2 cm



Plate	Plate Capacity Plates/slides per adapter/rotor	Adapter Order no. (international)	Adapter bottom shape Max. loading height	Max. g force Max. speed Centrifugation radius
	PCR plate 96 wells 1/2	 5825 711.009	Conical 47 mm/60 mm	2449 × g 3900 rpm 14.4 cm
Slide	CombiSlide 12 slides 12/48	 5825 706.005	Flat 47 mm/60 mm	1000 × g 2467 rpm 14.7 cm















DOMINIQUE DUTSCHER





## Technical data

Centrifuge 5804/5804 R/5810/5810 R  
English (EN)

## 10.5.12 Rotor S-4-72

		Max. g-force:	3234 × g
<b>Rotor S-4-72</b>	<b>Round bucket 250 mL</b>	Max. speed:	4200 rpm
Swing-bucket rotor with 4 × 250 mL round buckets		Max. load per bucket (adapter, tube and contents):	450 g

Vessel	Vessel Capacity Vessels per adapter/rotor	Adapter Order no. (international)	Adapter bottom shape Tube diameter Max. tube length	Max. g-force Max. speed Centrifugation radius
	Micro test tube 1.5/2 mL 26/104	 5804 794.001	Open Ø 11 mm 43 mm	3136 × g 4200 rpm 15.9 cm
	Micro test tube 5 mL 8/32	 5804 793.005	Conical Ø 17 mm × 60 mm	3215 × g 4200 rpm 16.3 cm
	Vessel 4 mL to 8 mL 14/56	 5804 789.008	Round Ø 13 mm × 104 mm 115 mm	3136 × g 4200 rpm 15.9 cm
	Vessel 7.5 mL to 12 mL 13/52	 5804 791.002	Round Ø 16 mm × 98 mm 112 mm	3096 × g 4200 rpm 15.7 cm
	Vessel 9 mL 12/48	 5804 792.009	Round Ø 17.5 mm × 100 mm 113 mm	3116 × g 4200 rpm 15.8 cm
	Conical tube 15 mL 8/32	 5804 783.000	Conical Ø 17 mm × 104 mm 120 mm	3234 × g 4200 rpm 16.4 cm
	Conical tube 50 mL 4/16	 5804 784.006	Conical Ø 29 mm × 109 mm 120 mm	3234 × g 4200 rpm 16.4 cm

Vessel	Vessel Capacity Vessels per adapter/rotor	Adapter Order no. (international)	Adapter bottom shape Tube diameter Max. tube length	Max. g-force Max. speed Centrifugation radius
	Conical tube, skirted 50 mL 2/8	 5804 785.002	Conical Ø 29 mm x 104 mm 120 mm	2602 × g 3900 rpm 15.3 cm
 	Centrifuge bottle 175 mL: BD 352076 250 mL: Nalgene 3120-0250/ 3122-0250 1/4	 5804 787.005	Round Ø 62 mm 130 mm	3155 × g 4200 rpm 16 cm



Only centrifuge conical tubes with the manufacturer's adapter.





DOMINIQUE DUTSCHER S.A.S.

**Technical data**

Centrifuge 5804/5804 R/5810/5810 R  
English (EN)

**10.5.13 Rotor F-35-48-17**









	Max. g-force:	5,005 x <i>g</i>
<b>Rotor F-35-48-17</b> Fixed-angle rotor with 48 steel cores	Max. speed:	5.500 rpm
	Max. load (sleeve, adapter, tube and contents):	48 x 56 g

Vessel	Vessel Capacity Vessels per adapter/rotor	Adapters Order no. (international)	Adapter bottom shape Tube diameter Max. tube length	Max. g-force Max. speed Centrifugation radius
	Vessel 7,5 to 12 mL 1/48		flat Ø 16 mm 127 mm	5,005 x <i>g</i> 5.500 rpm 14.8 cm
	Conical tube 15 mL 1/36		conical Ø 17 mm 127 mm	5,005 x <i>g</i> 5.500 rpm 14.8 cm



### 10.5.14 Rotor FA-45-48-11

	Max. g-force: Outer ring 19,083 x g Inner ring 16,816 x g
<b>Rotor FA-45-48-11</b> Aerosol-tight fixed-angle rotor for 48 tubes	Max. speed: 13,000 rpm Max. load (adapter, tube and contents): 48 x 3.75 g





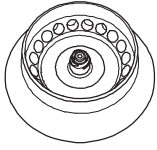

Tube	Tube  Capacity Tubes per adapter/ rotor	Adapter  Order no. (international)	Adapter bottom shape  Tube diameter	Max. g-force Outer ring Inner ring Max. speed Centrifugation radius Outer ring Inner ring
	Reaction tube  1.5 to 2 mL -/48		round  Ø 11 mm	19,083 x g 16,816 x g 13,000 rpm 10.1 cm 8.9 cm
	PCR tube  0.2 mL 1/48	 5425 715.005	conical  Ø 6 mm	15,115 x g 12,848 x g 13,000 rpm 8 cm 6.8 cm
	Reaction tube  0.4 mL 1/48	 5425 717.008	conical  Ø 6 mm	19,083 x g 16,816 x g 13,000 rpm 10.1 cm 8.9 cm
	Reaction tube  0.5 mL 1/48	 5425 716.001	-  Ø 8 mm	17,005 x g 14,737 x g 13,000 rpm 9 cm 7.8 cm
	Reaction tube  0.6 mL 1/48	 5425 716.001	-  Ø 8 mm	19,083 x g 16,816 x g 13,000 rpm 10.1 cm 8.9 cm

## Technical data

Centrifuge 5804/5804 R/5810/5810 R  
English (EN)

## 10.5.15 Rotor FA-45-20-17

	Max. g-force: $20,913 \times g$
<b>Rotor FA-45-20-17</b> Aerosol-tight fixed-angle rotor for 20 tubes	Max. speed: 13,100 rpm
	Max. load (adapter, tube and contents): $20 \times 9.5 \text{ g}$

Tube	Tube Capacity Tubes per adapter/ rotor	Adapter Order no. (international)	Adapter bottom shape Tube diameter	Max. g-force Max. speed Centrifugation radius
	Reaction tube 1.5 mL/2.0 mL 1/20	 5820 768.002	open Ø 11 mm	$18,227 \times g$ 13,100 rpm 9.5 cm
	Reaction tube 5 mL -/20	–	conical Ø 17 mm	$20,913 \times g$ 13,100 rpm 10.9 cm
	HPLC vessels 1/20	 5820 770.007	open Ø 11 mm	$17,076 \times g$ 13,100 rpm 8.9 cm
	Cryo tube 1.0 mL/2.0 mL 1/12	 5820 769.009	flat Ø 13 mm	$18,802 \times g$ 13,100 rpm 9.8 cm

## 11 Ordering information

### 11.1 Centrifuge 5804/5804 R

Please refer to our catalog.

Order no. (International)	Order no. (North America)	Description
5804 000.013 5804 000.137	022622552 022622501	<b>Centrifuge 5804</b> without rotor 230 V/50 – 60 Hz 120 V, 50 Hz – 60 Hz
5805 000.017 5805 000.130 5805 000.530	022623559 022623508 022625080	<b>Centrifuge 5804 R</b> refrigerated, without rotor 230 V/50 – 60 Hz 120 V/50 – 60 Hz, 15 A 120 V/50 – 60 Hz, 20 A

### 11.2 Centrifuge 5810/5810 R

Order no. (International)	Order no. (North America)	Description
5810 000.017 5810 000.130	022625055 022625004	<b>Centrifuge 5810</b> without rotor 230 V/50 – 60 Hz 120 V/50 – 60 Hz, with US-plug
5811 000.010 5811 000.134 5811 000.533	022625551 022625501 022625101	<b>Centrifuge 5810 R</b> refrigerated, without rotor 230 V/50 – 60 Hz 120 V/50 – 60 Hz, 15 A, with US-plug 120 V/50 – 60 Hz, 20 A, with US-plug

**Ordering information**

Centrifuge 5804/5804 R/5810/5810 R  
English (EN)

**11.3 Rotors****11.3.1 Rotor A-4-81 (only 5810/5810 R)****11.3.1.1 Rotor A-4-81, 500 mL bucket**

Order no. (International)	Order no. (North America)	Description
5810 718.007 5810 743.001	022638602 022638611	<b>Rotor A-4-81</b> for 500 mL rectangular buckets or MTP/Flex-buckets incl. 4 × 500 mL rectangular buckets without buckets
5810 730.007	022638629	<b>Rectangular bucket 500 mL</b> Set of 4
5810 724.007	022638661	<b>Aerosol-tight cap</b> for 500 mL rectangular buckets, 2 pieces
5810 733.006	022638670	<b>Replacement cap sealing for aerosol-tight caps</b> for 500 mL rectangular buckets, 4 pieces
5810 745.004 5810 746.000	022638704 022638707	<b>Adapter</b> for 500 mL rectangular buckets for 20 sample tubes (1.5/2.0 mL, max. Ø 11 mm), set of 2 for 20 blood collection tubes (1.2 – 5 mL, max. Ø 11 mm), set of 2
5810 720.001 5825 717.007 5810 748.003	022638700 022638718 022638721	for 24 tubes (2.6 – 7 mL, max. Ø 13 mm), set of 2 for 18 tubes (5 mL, Monovette, max. Ø 13 mm), set of 2 for 16 blood collection tubes (3 – 15 mL, max. Ø 16 mm), set of 2
5810 721.008 5810 722.004 5810 723.000 5810 739.004	022638726 022638742 022638769 022638904	for 16 tubes (7 – 17 mL, max. Ø 17.5 mm), set of 2 for 12 conical tubes (15 mL, max. Ø 17.5 mm), set of 2 for 5 conical tubes (50 mL, max. Ø 31 mm), set of 2 for 5 Centriprep Centrifugal Filter Units (max. Ø 31 mm), set of 2
5825 722.000 5810 728.002	022638921 022638785	for 1 bottle (180 – 250 mL, max. Ø 62 mm), set of 2 for 1 bottle (400 mL, max. Ø 81 mm), set of 2
5804 737.008	022654373	<b>Adapter</b> for 50 mL skirted conical tubes, set of 8
5810 734.002	022638688	<b>Rubber mat</b> for adapters for 500 mL rectangular buckets 4 pieces
5810 735.009	022638696	<b>Replacement clamp</b> for adapters for 500 mL rectangular buckets 2 pieces
5810 729.009 5820 707.003	022638653 022638657	<b>Wide-neck bottle</b> for Rotor A-4-81 400 mL, set of 2 500 mL, rectangular, set of 2
5810 718.309	022664174	<b>Rotor key</b> for Rotor A-4-81, S-4-104

### 11.3.1.2 Rotor A-4-81, MTP/Flex buckets

Order no. (International)	Order no. (North America)	Description
5810 725.003	022638807	<b>Rotor A-4-81-MTP/Flex</b> Swing-bucket rotor, incl. 4 MTP/Flex buckets
5810 741.009 5810 742.005	022638840 022638866	<b>MTP/Flex buckets for Rotor A-4-81 or A-4-81-MTP/Flex</b> for use with IsoRack and cell culture flask adapters as well as MTP and DWP 4 pieces 2 pieces
5825 708.008 5825 709.004	022638980 022638998	<b>IsoRack adapter</b> for 24 × 0.5 mL tubes in the IsoRack, 2 pcs. for 24 × 1.5/2.0 mL tubes in the IsoRack, 2 pcs.
5825 721.004	022510070	<b>IsoRack starter set for Flex buckets</b> 2 × IsoRack Adapter, 2 × IsoRacks with lid, 2 × IsoPack 0 °C for 0.5 mL and 1.5/2.0 mL tubes
5825 711.009 5825 713.001	022638947 022638955	<b>Adapter</b> used in A-4-81-MTP/Flex, A-4-62-MTP, A-2-DWP-AT and A-2-DWP for 96-well PCR plates, set of 2 for 384-well PCR plates, set of 2
5825 706.005	022638963	<b>Adapter</b> used in A-4-81-MTP/Flex, A-4-62-MTP and A-2-DWP CombiSlide Adapter, set of 2
5825 719.000	5825719000	<b>Adapter</b> used in A-4-81-MTP/Flex and A-4-62-MTP for 1 cell culture bottle, set of 2

### 11.3.1.3 Rotor A-4-81, buckets for conical tubes

Order no. (International)	Order no. (North America)	Description
5825 730.003	022638614	<b>Bucket for A-4-81</b> for 7 50 mL conical tubes, set of 4
5820 718.005	5820718005	<b>Adapter</b> used in FA-45-6-30 for 15 mL conical tubes, set of 7

**Ordering information**

Centrifuge 5804/5804 R/5810/5810 R  
English (EN)

**11.3.2 Rotor A-4-62 and A-4-62-MTP (only 5810/5810 R)****11.3.2.1 Rotor A-4-62**

<b>Order no. (International)</b>	<b>Order no. (North America)</b>	<b>Description</b>
5810 709.008	022638009	<b>Rotor A-4-62</b> incl. 4 × 250 mL rectangular buckets
5810 716.004	022638084	<b>Rectangular bucket 250 mL</b> Set of 4
5810 710.006	022638033	<b>Aerosol-tight cap</b> for 250 mL rectangular buckets, set of 2
5810 713.005	022638017	<b>Spare sealing for aerosol-tight caps</b> for 250 mL rectangular buckets Set of 4
5810 751.004 5810 750.008 5810 752.000 5810 753.007 5810 754.003 5810 756.006 5810 757.002 5810 759.005 5810 760.003 5810 761.000 5810 770.009 5810 755.000 5810 758.009 5810 763.002	022638220 022638203 022638246 022638262 022638301 022638327 022638360 022638386 022638408 022638424 022638441 022638289 022638343 022638351	<b>Adapter</b> for 250 mL rectangular buckets for 16 sample tubes (1.5/2.0 mL, max. Ø 11 mm), set of 2 for 25 tubes (1.2 – 5 mL, max. Ø 11 mm), set of 2 for 15 tubes (2.6 – 7 mL, max. Ø 13 mm), set of 2 for 12 tubes (3 – 15 mL, max. Ø 16 mm), set of 2 for 12 tubes (7 – 17 mL, max. Ø 17.5 mm), set of 2 for 8 tubes (7 – 18 mL, max. Ø 20 mm), set of 2 for 4 tubes (18 – 30 mL, max. Ø 26 mm), set of 2 for 4 tubes (30 – 50 mL, max. Ø 31 mm), set of 2 for 2 tubes (50 – 75 mL, max. Ø 35 mm), set of 2 for 1 tube (80 – 120 mL, max. Ø 45 mm), set of 2 for 1 bottle (180 – 250 mL, max. Ø 62 mm), set of 2 for 9 conical tubes (15 mL, max. Ø 17.5 mm), set of 2 for 3 conical tubes (50 mL, max. Ø 31 mm), set of 2 for 4 conical tubes (50 mL), operation w/o aerosol-tight cap, set of 2
5804 737.008	022654373	<b>Adapter</b> for 50 mL skirted conical tubes, set of 8
5810 782.007	022638483	<b>Rubber mat</b> for adapters for 250 mL rectangular buckets Set of 4
5810 781.000	022662431	<b>Replacement clamp</b> for adapters for 250 mL rectangular buckets Set of 2
5810 783.003	022638459	<b>Rubber mat</b> for adapter 5810 770.009/022638441 Set of 4

### 11.3.2.2 Rotor A-4-62-MTP

Order no. (International)	Order no. (North America)	Description
5810 711.002	022638041	<b>Rotor A-4-62-MTP</b> incl. 4 MTP buckets
5810 702.003	022638068	<b>MTP bucket for A-4-62</b> for 4 MTP or 1 DWP Set of 4
5825 711.009 5825 713.001	022638947 022638955	<b>Adapter</b> used in A-4-81-MTP/Flex, A-4-62-MTP, A-2-DWP-AT and A-2-DWP for 96-well PCR plates, set of 2 for 384-well PCR plates, set of 2
5825 706.005	022638963	<b>Adapter</b> used in A-4-81-MTP/Flex, A-4-62-MTP and A-2-DWP CombiSlide Adapter, set of 2

### 11.3.3 Rotor A-4-44

Order no. (International)	Order no. (North America)	Description
5804 709.004	022637401	<b>Rotor A-4-44</b> incl. 4 x 100 mL rectangular buckets
5804 741.005	022637436	<b>Rectangular bucket 100 mL</b> 4 pieces
5804 712.005	022637428	<b>Aerosol-tight cap</b> for 100 mL rectangular buckets, set of 2
5804 713.001	022637444	<b>4 Replacement gasket for aerosoltight caps</b> for 100 mL rectangular buckets, set of 4
5804 751.000 5804 750.004 5804 752.007 5804 753.003 5804 754.000 5804 756.002 5804 757.009 5804 759.001 5804 760.000 5804 761.006 5804 755.006 5804 717.007 5804 758.005 5804 718.003	022637525 022637509 022637541 022637568 022637584 022637622 022637649 022637681 022637703 022637720 022637606 022637614 022637665 022637673	<b>Adapter for 100 mL rectangular bucket</b> for 12 sample tubes (1.5/2.0 mL, max. Ø 11 mm), set of 2 for 14 tubes (1.2 – 5 mL, max. Ø 11 mm), set of 2 for 9 tubes (2.6 – 7 mL, max. Ø 13 mm), set of 2 for 7 tubes (3 – 15 mL, max. Ø 16 mm), set of 2 for 6 tubes (7 – 17 mL, max. Ø 17.5 mm), set of 2 for 4 tubes (7 – 18 mL, max. Ø 20 mm), set of 2 for 2 tubes (18 – 30 mL, max. Ø 26 mm), set of 2 for 1 tube (30 – 50 mL, max. Ø 31 mm), set of 2 for 1 tube (50 – 75 mL, max. Ø 35 mm), set of 2 for 1 tube (80 – 100 mL, max. Ø 45 mm), set of 2 for 4 conical tubes (15 mL, max. Ø 17.5 mm), set of 2 for 2 conical tubes (15 mL, max. Ø 17.5 mm), set of 2 for 1 conical tube (50 mL, max. Ø 31 mm), set of 2 for 1 conical tube (50 mL, max. Ø 31 mm), set of 2
5804 737.008	022654373	<b>Adapter</b> for 50 mL skirted conical tubes, set of 8

**Ordering information**

Centrifuge 5804/5804 R/5810/5810 R  
English (EN)

Order no. (International)	Order no. (North America)	Description
5804 782.003	022662503	<b>Rubber mat</b> for adapters of Rotor A-4-44 Set of 4
5804 781.007	022662511	<b>Replacement clamp</b> for adapters of rotor A-4-44 Set of 2
5804 706.005	022637452	<b>Buckets</b> for A-4-44 for 2 Falcon tubes (50 mL, max. Ø 31 mm), set of 4
5804 728.009	022637479	<b>Adapter</b> Form inserts for buckets with conical tubes for 1 conical tube (50 mL, max. Ø 31 mm), set of 8

**11.3.4 Rotor A-2-DWP-AT (only 5810/5810 R)**

Order no. (International)	Order no. (North America)	Description
5820 710.004	5820710004	<b>Rotor A-2-DWP-AT</b> incl. 2 buckets, 2 aerosol-tight caps and 2 plate holders
5820 711.000	5820711000	<b>Bucket for rotor A-2-DWP-AT</b> 2 pieces
5820 713.003	5820713003	<b>Aerosol-tight cap</b> 2 pieces
5820 705.000	5820705000	<b>Spare seal for aerosoltight cap</b> 2 pieces
5820 756.004	5820756004	<b>Plate carrier</b> Rotors A-2-DWP-AT, S-4-104, S-4x750 2 pieces
5825 711.009	022638947	<b>Adapter</b> used in A-4-81-MTP/Flex, A-4-62-MTP, A-2-DWP-AT and A-2-DWP for 96-well PCR plates, set of 2 for 384-well PCR plates, set of 2
5825 713.001	022638955	

Aerosol tightness tested and certified by the Centre of Emergency Preparedness and Response, Health Protection Agency, Porton Down (UK).



### 11.3.5 Rotor A-2-DWP

Order no. (International)	Order no. (North America)	Description
5804 740.009	022638564	<b>Rotor A-2-DWP</b> Deepwell plates rotor, incl. 2 buckets
5804 743.008	022638556	<b>Plate bucket</b> used in A-2-DWP 2 pieces
5825 718.003	5825718003	<b>SBS adapter</b> for plates with rims in the SBS format Set of 2
5825 708.008 5825 709.004	022638980 022638998	<b>IsoRack adapter</b> for 24 × 0.5 mL tubes in the IsoRack, 2 pcs. for 24 × 1.5/2.0 mL tubes in the IsoRack, 2 pcs.
5825 711.009 5825 713.001	022638947 022638955	<b>Adapter</b> used in A-4-81-MTP/Flex, A-4-62-MTP, A-2-DWP-AT and A-2-DWP for 96-well PCR plates, set of 2 for 384-well PCR plates, set of 2
5825 706.005	022638963	<b>Adapter</b> used in A-4-81-MTP/Flex, A-4-62-MTP and A-2-DWP CombiSlide Adapter, set of 2

DOMINIQUE DUCHÊTEAU SAS

**Ordering information**

Centrifuge 5804/5804 R/5810/5810 R  
English (EN)

**11.3.6 Rotor FA-45-6-30**

Order no. (International)	Order no. (North America)	Description
5820 715.006	5820715006	<b>Rotor FA-45-6-30</b> aerosol-tight*, aluminum, 45° angle, 6 places, for 15/ 50 mL conical tubes, incl. rotor lid (aluminum)
5820 716.002	5820716002	<b>Rotor lid for FA-45-6-30</b> aerosol-tight, aluminum
5418 709.008	022652109	<b>Seal for rotor lid</b> FA-45-18-11 (5418/5418 R), FA-45-6-30 (5804/5804 R/5810/ 5810 R), FA-6x50 (5920 R) 5 pieces
5820 717.009	5820717009	<b>Adapter</b> used in rotor FA-45-6-30 for 1 conical tubes 15 mL (max. Ø 17 mm), set of 2 pieces for 1 Oak Ridge 16 mL (max. Ø 18 mm), set of 2 pieces for 1 Oak Ridge 30 mL (max. Ø 26 mm), set of 2 pieces for 1 Oak Ridge 35 mL (max. Ø 30 mm), set of 2 pieces for 1 tube 5 mL (max. Ø 17 mm), set of 2 pieces for 1 round-bottom and blood collection tube (13 mm × 75 mm), set of 2 pieces for 1 round-bottom and blood collection tube (13 mm × 100 mm), set of 2 pieces for 1 Oak Ridge 10 mL, round-bottom and blood collection tube (13 mm × 75 mm), set of 2 pieces for 1 round-bottom and blood collection tube (16 mm × 100 mm), set of 2 pieces for 1 round-bottom and blood collection tube (17,5 mm × 100 mm), set of 2 pieces
5820 720.000	5820720000	
5820 721.006	5820721006	
5820 722.002	5820722002	
5820 730.005	5820730005	
5820 726.008	5820726008	
5820 725.001	5820725001	
5820 728.000	5820728000	
5820 727.004	5820727004	
5820 729.007	5820729007	

Aerosol tightness tested and certified by the Centre of Emergency Preparedness and Response, Health Protection Agency, Porton Down (UK).

### 11.3.7 Rotor F-34-6-38

Order no. (International)	Order no. (North America)	Description
5804 727.002	022637207	<b>Rotor F-34-6-38</b> 34° angle, 6 places for 85 mL tubes, incl. rotor lid
5804 727.509	022662961	<b>Rotor lid F-34-6-38, F-6x85</b> aluminum
5804 770.005	022637215	<b>Adapter</b> used in F-34-6-38
5804 777.000	5804777000	
5804 738.004	022637279	
5804 739.000	022637282	
5804 771.001	022637223	
5804 776.003	022637274	
5804 772.008	022637231	
5804 773.004	022637240	
5804 774.000	022637258	
5804 775.007	022637266	

for 4 sample tubes 1.5/2.0 mL (max. Ø 11 mm), set of 2  
 for 1 tube 5 mL (max. Ø 17 mm), set of 2 pieces  
 for 3 round-bottom and blood collection tubes (13 × 75 mm), set of 2 pieces  
 for 3 round-bottom and blood collection tubes (13 × 100 mm), set of 2 pieces  
 for 2 tubes (7 bis 15 mL, max. Ø 16 mm), set of 2  
 for 1 conical tube (15 mL, max. Ø 17 mm), set of 2  
 for 1 tube (15 bis 18 mL, max. Ø 18 mm), set of 2  
 for 1 tube (20 bis 30 mL, max. Ø 26 mm), set of 2  
 for 1 tube (50 mL, max. Ø 29 mm), set of 2  
 for 1 conical tube (50 mL, max. Ø 29.5 mm), set of 2

**Ordering information**

Centrifuge 5804/5804 R/5810/5810 R  
English (EN)

**11.3.8 Rotor FA-45-30-11 and rotor F-45-30-11**

Order no. (International)	Order no. (North America)	Description
5804 726.006	022637100	<b>Rotor FA-45-30-11</b> aerosol-tight*, 45° angle, 30 places for 1.5/2.0 mL tubes, incl. rotor lid (aluminum)
5804 736.001	022637126	<b>Rotor lid for FA-45-30-11</b> aerosol-tight, aluminum
5804 715.004	022637002	<b>Rotor F-45-30-11</b> 45° angle, 30 places for 1.5/2.0 mL tubes, incl. rotor lid (aluminum)
5804 715.403	022662970	<b>Rotor lid for F-45-30-11</b> not aerosol-tight, aluminum
5425 715.005 5425 717.008 5425 716.001	022636260 022636243 022636227	<b>Adapter</b> used in FA-45-30-11 and F-45-30-11 for 1 PCR tube (0.2 mL, max. Ø 6 mm), set of 6 for 1 micro test tube (0.4 mL, max. Ø 6 mm), set of 6 for 1 sample tube (0.5 mL, max. Ø 6 mm) or 1 Microtainer (0.6 mL, max. Ø 8 mm), set of 6

**11.3.9 Rotor F-45-48-PCR**

Order no. (International)	Order no. (North America)	Description
5804 735.005	022638581	<b>Rotor F-45-48-PCR</b> 45° angle, for 6 × 8-tube strips, 6 × 5-tube strips or 48 × 0.2 mL PCR tubes

**11.3.10 Rotor T-60-11**

Order no. (International)	Order no. (North America)	Description
5804 730.003	022638505	<b>Rotor T 60-11</b> for 60 × 1.5/2.0 mL tubes incl. rotor lid, and 6 adapters for 1.5/2 mL sample tubes
5804 731.000 5804 732.006	022638521 022638548	<b>Adapter</b> used in T-60-11 for 10 sample tubes (1,5/2,0 mL, max. Ø 11 mm), set of 6 for 20 sample tubes (0.4 mL, max. Ø 6 mm), set of 6

### 11.3.11 Rotor S-4-104

Order no. (International)	Order no. (North America)	Description
5820 740.000	5820740000	<b>Rotor S-4-104</b> 4 × 750 mL incl. 4 round buckets 750 mL for Centrifuges 5810/5810 R
5820 754.001	5820754001	<b>Rotor S-4-104</b> incl. 4 plate buckets (aerosol-tight capable) inkl. plate carrier
5820 755.008	5820755008	<b>Rotor S-4-104</b> without buckets
5825 740.009 5825 739.000 5825 738.004 5825 736.001 5825 743.008 5825 734.009 5825 733.002 5825 732.006 5825 741.005 5825 745.000 5825 744.004	5825740009 5825739000 5825738004 5825736001 5825743008 5825734009 5825733002 5825732006 5825741005 5825745000 5825744004	<b>Adapter</b> used in rotor S-4-104 for 50 tubes 1,5 mL/2,0 mL (max. Ø 11 mm), set of 2 pieces for 14 tubes 5 mL (max. Ø 17 mL), set of 2 pieces for 23 round-bottom tubes and blood collection tubes (13 mm × 75 - 100 mm), set of 2 pieces for 20 round-bottom tubes and blood collection tubes (16 mm × 75 - 100 mm), set of 2 pieces for 20 round-bottom tubes and blood collection tubes (17,5 mm × 100 mm), set of 2 pieces for 14 conical tubes 15 mL (max. Ø 17 mm), set of 2 pieces for 7 conical tubes 50 mL (max. Ø 30 mm), set of 2 pieces for 5 skirted conical tubes (max. Ø 30 mm), set of 2 pieces für 1 tube 175 - 250 mL (max. Ø 62 mm), set of 2 pieces for 1 Corning 500 mL Centrifuge Tube (max. Ø 96 mL), set of 2 pieces for 1 wide-neck bottle 750 mL (max. Ø 102 mL), set of 2 pieces
5820 708.000	5820708000	<b>Wide-neck bottle</b> for rotor S-4-104 750 mL, set of 2
5820 742.003 5820 741.007	5820742003 5820741007	<b>Bucket 750 mL</b> for rotor S-4-104 Set of 2 Set of 4
5820 744.006 5820 743.000	5820744006 5820743000	<b>Plate bucket (aerosol-tight capable)</b> for rotor S-4-104, incl. base plate and plate carrier Set of 2 Set of 4
5820 746.009 5820 745.002	5820746009 5820745002	<b>Plate bucket</b> for rotor S-4-104 Set of 2 Set of 4
5820 758.007 5820 757.000	5820758007 5820757000	<b>Plate bucket (open)</b> for rotor S-4-104 set of 2 set of 4

**Ordering information**

Centrifuge 5804/5804 R/5810/5810 R  
English (EN)

Order no. (International)	Order no. (North America)	Description
5820 748.001	5820748001	<b>Aerosol-tight cap</b> Rotors S-4-104, S-4x750, Plate Bucket 2 pieces
5820 756.004	5820756004	<b>Plate carrier</b> Rotors A-2-DWP-AT, S-4-104, S-4x750 2 pieces
5820 751.002	5820751002	<b>Base element for plate buckets</b> for rotor S-4-104 Set of 2 pieces
5820 780.002	5820780002	<b>Sealings for aerosol-tight caps</b> Rotors S-4-104, S-4x750, S-4x1000, Plate/Tube Bucket 4 pieces
5820 747.005	5820747005	<b>Aerosol-tight cap</b> Rotors S-4-104, S-4x750, S-4x1000, round bucket 750 mL/ 1000 mL 2 pieces
5820 749.008	5820749008	<b>Sealings for aerosol-tight caps</b> Rotors S-4-104, S-4x750, S-4x1000, round bucket 750 mL/ 1000 mL 4 pieces
5810 718.309	022664174	<b>Rotor key</b> for Rotor A-4-81, S-4-104

### 11.3.12 Rotor S-4-72

Order no. (International)	Order no. (North America)	Description
5804 746.007	5804746007	<b>Rotor S-4-72</b> 4 × 250 mL incl. 4 round buckets 250 mL for Centrifuges 5804/5804 R/ 5810/5810 R
5804 794.001 5804 793.005 5804 789.008 5804 791.002 5804 792.009 5804 783.000 5804 784.006 5804 785.002 5804 787.005	5804794001 5804793005 5804789008 5804791002 5804792009 5804783000 5804784006 5804785002 5804787005	<b>Adapter</b> used in rotor S-4-72 for 26 tubes 1,5/2,0 mL (max. Ø 11 mm), set of 2 pieces for 8 tubes 5 mL (max. Ø 17 mm), set of 2 pieces for 14 round-bottom und blood collection tubes (13 mm × 75 - 100 mm), set of 2 pieces for 13 round-bottom und blood collection tubes (16 mm × 75 - 100 mm), set of 2 pieces for 12 round-bottom und blood collection tubes (17,5 mm × 100 mm), set of 2 pieces for 8 conical tubes 15 mL (max. Ø 17 mm), set of 2 pieces for 4 conical tubes 50 mL (max. Ø 30 mm), set of 2 pieces for 2 conical tubes 15 mL, 50 mL (max. Ø 17 mm, Ø 30 mm), set of 2 pieces for 1 tube 175 - 250 mL (max. Ø 62 mm), set of 2 pieces
5804 747.003	5804747003	<b>Buckets 250 mL</b> for Rotor S-4-72 4 pieces

### 11.3.13 Rotor F-35-48-17

Order no. (International)	Order no. (North America)	Description
5820 771.003	5820771003	<b>Rotor F-35-48-17</b> incl. 24 steel sleeves and adapter for 24 × 15 mL tubes for Centrifuges 5804/5804 R/5810/ 5810 R
5820 772.000	5820772000	<b>Rotor F-35-48-17</b> incl. 48 steel sleeves and adapter for 48 × 15 mL tubes for Centrifuges 5804/5804 R/5810/ 5810 R
5820 774.002	5820774002	<b>Steel sleeves incl. adapter</b> for Rotor F-35-48-17 for 36 conical tubes 15 mL and 48 round-bottom and blood collection tube (max. Ø 16 mm × 100 mm), set of 24 pieces

**Ordering information**

Centrifuge 5804/5804 R/5810/5810 R  
English (EN)

**11.3.14 Rotor FA-45-48-11**

Order no. (International)	Order no. (North America)	Description
5820 760.001	5820760001	<b>Rotor FA-45-48-11</b> aerosol-tight, for 48 × 1.5/2 mL tubes, incl. aerosol-tight rotor lid for Centrifuges 5804/5804 R/5810/5810 R
5820 761.008	5820761008	<b>Rotor lid, aerosol-tight</b> for rotor FA-45-48-11 1 pieces
5820 767.006	5820767006	<b>Seal for rotor lid</b> FA-45-24-11-Kit (5427 R/530/5430 R), FA-45-48-11 (5427 R/5430/5430 R, 5804/5804 R/5810/5810 R), FA-30x2 (5920R), FA-48x2 (5920R) 5 pieces

**11.3.15 Rotor FA-45-20-17**

Order no. (International)	Order no. (North America)	Description
5820 765.003	5820765003	<b>Rotor FA-45-20-17</b> aerosol-tight, for 20 × 5 mL tubes, incl. aerosol-tight rotor lid for Centrifuges 5804/5804 R/5810/5810 R
5820 766.000	5820766000	<b>Rotor lid, aerosol-tight</b> for rotor FA-45-20-17 1 pieces
5409 718.002	5409718002	<b>Seal for rotor lid</b> FA-45-20-17 (5804/5804 R/5810/5810R), FA-20x5 (5920R) 5 pieces
5820 768.002 5820 769.009	5820768002 5820769009	<b>Adapter</b> used in rotor FA-45-12-17 (5427 R), FA-45-16-17 (5430/5430 R), FA-45-20-17 (5804/5804 R/5810/5810 R) for 1 tube 1,5 mL/2,0 mL (max. Ø 11 mm), set of 10 pieces for 1 Cryo tube, set of 4 pieces
5820 770.007	5820770007	<b>Adapter</b> used in Rotor FA-45-12-17 (5427 R), FA-45-16-17 (5430/5430 R), FA-45-20-17 (5804/5804 R/5810/5810 R) for 1 HPLC vial, set of 10 pieces



## 11.4 Accessories

Order no. (International)	Order no. (North America)	Description
5804 720.008	022639021	<b>Rotor stand</b> suitable for all rotors of Centrifuge 5804/5804 R/5810/5810 R
5810 350.050	022634330	<b>Pivot grease</b> Tube 20 mL
5810 350.018 5810 718.309	022664166 022664174	<b>Rotor key</b> Standard for Rotor A-4-81, S-4-104
5811 001.068	022662678	<b>Tray for condensation water</b>

### 11.4.1 Mains/power cord for Centrifuge 5804 and Centrifuge 5810

Order no. (International)	Order no. (North America)	Description
0113 200.111 0013 594.490 0013 613.952 0013 592.454 0113 200.863 0013 613.973	– – – – 022664999 –	<b>Mains/power cord</b> 230 V/50 Hz, Europe 230 V/50 Hz, GB/HK 230 V/50 Hz, CN 230 V/50 Hz, AUS 120 V/60 Hz, USA 230 V/50 Hz, ARG
5804 652.002	–	<b>Mains/power cable</b> 202 V, Japan

### 11.4.2 Mains/power cord for Centrifuge 5804 R and Centrifuge 5810 R

Order no. (International)	Order no. (North America)	Description
5821 850.110	–	<b>Mains cable</b> 230 V
0113 204.680 0013 613.953 0113 204.699 0113 200.863 0113 205.105	– – – 022664999 –	<b>Mains/power cord</b> 230 V/50 Hz, GB/HK 230 V/50 Hz, CN 230 V/50 Hz, AUS 120 V/60 Hz, USA 230 V/50 Hz, ARG
5821 609.005	–	<b>Mains/power cable</b> 202 V, Japan

**Ordering information**

Centrifuge 5804/5804 R/5810/5810 R  
English (EN)

DOMINIQUE DUTSCHER SAS

## Sommaire

<b>1</b>	<b>Notes d'application</b> .....	<b>113</b>
1.1	Utilisation de ce manuel .....	113
<b>2</b>	<b>Consignes générales de sécurité</b> .....	<b>114</b>
2.1	Utilisation appropriée .....	114
2.2	Exigences s'appliquant à l'utilisateur .....	114
2.3	Limites d'utilisation.....	114
2.3.1	Explication de la directive ATEX (2014/34/UE) .....	114
2.3.2	Durée d'utilisation maximale des accessoires .....	115
2.4	Remarques sur la responsabilité du fabricant .....	117
2.5	Dangers résultant d'une utilisation appropriée .....	117
2.5.1	Dommages physiques ou matériels .....	117
2.5.2	Manipulation incorrecte de la centrifugeuse .....	120
2.5.3	Manipulation incorrecte des rotors.....	120
2.5.4	Contrainte extrême des tubes de centrifugation.....	122
2.5.5	Centrifugation anti-aérosols .....	123
2.6	Consignes de sécurité sur l'appareil.....	124
<b>3</b>	<b>Désignation</b> .....	<b>125</b>
3.1	Aperçu des produits .....	125
<b>4</b>	<b>Installation</b> .....	<b>126</b>
4.1	Sélectionner un emplacement.....	126
4.2	Préparer l'installation .....	126
4.3	Installation de l'appareil .....	127
<b>5</b>	<b>Utilisation</b> .....	<b>129</b>
5.1	Commandes.....	129
5.2	Préparation à la centrifugation .....	130
5.2.1	Mise en marche de la centrifugeuse.....	130
5.2.2	Mise en place du rotor .....	130
5.2.3	Reconnaissance automatique du rotor .....	131
5.2.4	Rotor chargé .....	131
5.2.5	Fermeture du couvercle de la centrifugeuse.....	135
5.3	Refroidissement (seulement 5804 R/5810 R) .....	136
5.3.1	Réglage de la température .....	136
5.3.2	Affichage de la température .....	136
5.3.3	Contrôle de la température .....	136
5.3.4	FastTemp .....	136
5.3.5	Réfrigération continue .....	137
5.4	Centrifugation .....	138
5.4.1	Centrifugation avec réglage du temps .....	138
5.4.2	Autres possibilités de centrifugations : fonctionnement continu et Short Spin .....	138
5.4.3	Retirer le rotor.....	139
5.4.4	Mode standby .....	139

<b>6</b>	<b>Description détaillée et fonction des éléments de commande</b>	<b>140</b>
6.1	Réglage du rayon	140
6.2	Réglage des rampes d'accélération et de freinage	140
6.3	Réglage mode de décompte du temps (At set rpm)	140
6.4	Enregistrer un programme	141
6.5	Charger un programme	141
6.6	Supprimer un programme	142
6.7	Fonctions spéciales	142
6.7.1	Affichage des heures d'utilisation	142
6.7.2	Activation/désactivation du signal d'avertissement	142
6.7.3	Quitter la fonction Service	142
<b>7</b>	<b>Entretien</b>	<b>143</b>
7.1	Maintenance	143
7.2	Préparation du nettoyage / de la désinfection	143
7.3	Nettoyage / désinfection	144
7.3.1	Nettoyage / désinfection de l'appareil	145
7.3.2	Nettoyage et désinfection du rotor	146
7.4	Consignes d'entretien supplémentaires pour les centrifugeuses refroidies	146
7.5	Bris de verre	147
7.6	Décontamination avant l'expédition	147
<b>8</b>	<b>Résolution des problèmes</b>	<b>148</b>
8.1	Remise à zéro du disjoncteur	148
8.2	Pannes générales	148
8.3	Messages d'erreur	149
8.4	Déverrouillage de secours	151
<b>9</b>	<b>Transport, stockage et mise au rebut</b>	<b>152</b>
9.1	Transport	152
9.2	Stockage	152
9.3	Mise au rebut	153

## 1 Notes d'application

### 1.1 Utilisation de ce manuel

- ▶ Lisez intégralement le présent manuel d'utilisation avant de procéder à la première mise en service de l'appareil. Observez également les notices d'utilisation des accessoires.
- ▶ Vous trouverez également une description détaillée de l'appareil dans la version anglaise et française de cette notice.

Vous trouverez également une vue d'ensemble des rotors, des caractéristiques techniques et de la nomenclature de commande dans la version anglaise et française.

- ▶ Ce manuel d'utilisation fait partie du produit. Conservez-le bien accessible.
- ▶ Lorsque vous remettez l'appareil à un tiers, pensez toujours à joindre le manuel d'utilisation.
- ▶ La version actuelle du manuel d'utilisation est disponible dans d'autres langues sur notre site Internet [www.eppendorf.com/manuals](http://www.eppendorf.com/manuals).

## 2 Consignes générales de sécurité

### 2.1 Utilisation appropriée

La Centrifuge 5804/5804 R/5810/5810 R sert à séparer des mélanges de substances liquides de densités différentes, en particulier pour le traitement et l'analyse d'échantillons du corps humain d'une application de diagnostic in-vitro, afin de permettre une utilisation du diagnostic in-vitro conforme à l'usage prévu. Cette centrifugeuse et ses composants est un diagnostic in-vitro au sens de la directive 98/79/CE du Parlement Européen et du Conseil du 27 octobre 1998.

Les centrifugeuses Eppendorf sont exclusivement destinées à être utilisées en intérieur et par du personnel spécialisé et formé.

### 2.2 Exigences s'appliquant à l'utilisateur

L'appareil et les accessoires ne doivent être utilisés que par un personnel spécialisé formé.

Avant l'utilisation, lisez soigneusement le manuel d'utilisation et la notice d'utilisation des accessoires et familiarisez-vous avec le mode de fonctionnement de l'appareil.

### 2.3 Limites d'utilisation

#### 2.3.1 Explication de la directive ATEX (2014/34/UE)



**DANGER ! Risque d'explosion.**

- ▶ Ne pas utiliser l'appareil dans des pièces où l'on travaille avec des substances explosibles.
- ▶ Ne pas utiliser cet appareil pour modifier des substances explosives ou à forte réaction.
- ▶ Ne pas utiliser cet appareil pour modifier des substances qui pourraient engendrer une atmosphère explosive.

La Centrifuge 5804/5804 R/5810/5810 R ne convient pas à une utilisation dans les atmosphères à haut risque d'explosion en raison de sa construction et des conditions ambiantes présentes à l'intérieur de l'appareil.

C'est pourquoi, l'appareil ne doit être utilisé que dans un environnement sécurisé, p. e. dans l'environnement ouvert d'un laboratoire aéré ou d'une hotte d'évacuation. Il est interdit d'utiliser des substances pouvant potentiellement créer une atmosphère explosive. La prise de décision finale au regard des risques liés à l'utilisation de telles substances revient à l'utilisateur.

### 2.3.2 Durée d'utilisation maximale des accessoires

---



**AVERTISSEMENT ! Risque de blessures suite à des dommages chimiques ou mécaniques des accessoires.**

Même des rayures ou fissures légères peuvent gravement endommager l'appareil.

- ▶ Protégez toutes les pièces mécaniques des accessoires des éventuelles détériorations mécaniques.
- ▶ Avant chaque utilisation, vérifiez que les accessoires ne sont pas endommagés. Remplacez tout accessoire endommagé.
- ▶ N'utilisez pas de rotors, de couvercles de rotor, de nacelles, de flacons ou de couvercles présentant des traces de corrosion ou des dommages mécaniques (par ex. des déformations).
- ▶ N'utilisez pas d'accessoires dont la durée maximale d'utilisation est dépassée.
- ▶ Lors de la mise en place de la nacelle et des rotors, veillez à ne pas rayer les surfaces.



**ATTENTION ! Risque de blessure par couvercles de rotor ou capuchons chimiquement endommagés.**

Les couvercles de rotor ou capuchons transparents en PC, PP ou PEI peuvent perdre de leur rigidité sous l'action de solvants organiques (p. ex phénol, chloroforme).

- ▶ Lorsque des couvercles de rotor ou capuchons sont entrés en contact avec des solvants organiques, nettoyez-les immédiatement.
  - ▶ Contrôlez régulièrement l'absence de dommages et de fissures sur les couvercles de rotor ou les capuchons.
  - ▶ Remplacez immédiatement les couvercles de rotor ou les capuchons présentant des fissures ou des colorations laiteuses.
-

Les rotors suivants, avec leurs béciers, nacelles et couvercles ont, à partir de la première mise en service, une durée d'utilisation limitée au nombre d'années ou au nombre de cycles indiqués dans le tableau (en fonction de ce qui se produit en premier).

<b>Rotor</b>	<b>Durée d'utilisation maximale à partir de la mise en service</b>	
A-2-DWP-AT	100 000 cycles	7 ans
A-2-DWP	34 000 cycles	7 ans
A-4-44	34 000 cycles	7 ans
A-4-62	40 000 cycles	7 ans
A-4-81	100 000 cycles	7 ans
F-34-6-38	75 000 cycles	7 ans
FA-45-6-30	100 000 cycles	7 ans
FA-45-48-11	100 000 cycles	7 ans
FA-45-20-17	100 000 cycles	7 ans
F-35-48-17	100 000 cycles	7 ans
S-4-72	100 000 cycles	7 ans
S-4-104	100 000 cycles	7 ans
T-60-11	n. a.	7 ans

<b>Accessoires</b>	<b>Durée d'utilisation maximale à partir de la mise en service</b>	
Couvercle de rotor, anti-aérosols, sans joints interchangeables	50 cycles d'autoclavage	–
Couvercle de rotor QuickLock		3 ans
Joints des couvercles de rotor QuickLock	50 cycles d'autoclavage	–
Couvercles de rotor et capuchons en polycarbonate (PC), polypropylène (PP) ou polyéthérimide (PEI)	50 cycles d'autoclavage	3 ans
Adaptateur	–	1 an

Pour tous les autres rotors et couvercles de rotor de cette centrifugeuse, il n'y a pas de limitation de la durée d'utilisation tant que les conditions préalables suivantes sont remplies :

- utilisation conforme à l'usage,
- entretien recommandé,
- parfait état.

La date de fabrication est gravée sur les rotors et les béciers sous la forme 03/15 ou 03/2015 (= mars 2015). La date de fabrication est gravée à l'intérieur du couvercle de rotor en plastique sous forme de cadran horaire ⌚.

Afin de garantir l'étanchéité aux aérosols, il faut :

- Remplacer le couvercle de rotor et les capuchons anti-aérosols au bout de 50 cycles d'autoclavage.
- Remplacer le joint des couvercles de rotor QuickLock au bout de 50 cycles d'autoclavage.



## 2.4 Remarques sur la responsabilité du fabricant

Dans les cas suivants, la garantie de protection de l'appareil peut être affectée. L'exploitant est responsable des dommages matériels et des blessures engendrés :

- L'appareil n'est pas utilisé conformément au manuel d'utilisation.
- L'appareil est utilisé de manière non conforme.
- L'appareil est utilisé avec des accessoires ou des consommables non recommandés par Eppendorf.
- La maintenance ou les réparations sont effectuées par des personnes non autorisées par Eppendorf.
- L'utilisateur effectue des modifications non autorisées sur l'appareil.

## 2.5 Dangers résultant d'une utilisation appropriée

### 2.5.1 Dommages physiques ou matériels



#### **AVERTISSEMENT ! Électrocution à cause de dommages à l'appareil ou au câble secteur.**

- ▶ Enclenchez l'appareil seulement si l'appareil et le câble secteur ne sont pas endommagés.
- ▶ Mettez en marche seulement des appareils qui ont été installés ou réparés de manière appropriée.
- ▶ En cas de danger, mettez l'appareil hors tension. Débranchez la fiche secteur de l'appareil ou de la prise de courant. Utilisez le dispositif de sectionnement prévu (par ex. interrupteur d'arrêt d'urgence au sein du laboratoire).



#### **AVERTISSEMENT ! Tensions électriques mortelles à l'intérieur de l'appareil.**

Si vous touchez des pièces sous haute tension, vous risquez l'électrocution. L'électrocution entraîne des lésions cardiaques et paralyse la respiration.

- ▶ Assurez-vous que le boîtier est fermé et n'est pas endommagé.
- ▶ Ne retirez pas l'appareil.
- ▶ Veillez à ce qu'aucun liquide ne pénètre dans l'appareil.

L'appareil ne doit être ouvert que par le personnel de maintenance autorisé.



#### **AVERTISSEMENT ! Danger à cause d'une tension d'alimentation inappropriée.**

- ▶ Branchez l'appareil seulement à des sources de courant qui correspondent aux exigences électriques indiquées sur la plaque d'identification.
- ▶ Utilisez seulement des prises de courant avec terre et des câbles secteur appropriés.



**AVERTISSEMENT ! Dangers pour la santé à cause de liquides infectieux et de germes pathogènes.**

- ▶ Lors de l'utilisation de liquides infectieux et de germes pathogènes, observez les directives nationales, le niveau de sécurité biologique de votre laboratoire ainsi que les fiches de données de sécurité et les modes d'emploi des fabricants.
- ▶ Lors de la centrifugation de ces substances, utilisez des systèmes de fermeture anti-aérosols.
- ▶ Utilisez plus d'un seul joint biologique anti-aérosols si vous travaillez avec des germes pathogènes d'un groupe de risque élevé.
- ▶ Portez votre équipement de protection individuelle.
- ▶ Consultez les réglementations sur la manipulation des germes ou des substances biologiques du groupe de risques II ou plus, indiquées dans le "Laboratory Biosafety Manual" (source : World Health Organisation, Laboratory Biosafety Manual, dans la version en vigueur).



**AVERTISSEMENT ! Risque de blessure lors de l'ouverture ou de la fermeture du couvercle de la centrifugeuse.**

Il est possible de se pincer les doigts lors de l'ouverture ou de la fermeture du couvercle de la centrifugeuse.

- ▶ Ne mettez les doigts ni entre le couvercle et l'appareil ni dans le mécanisme de verrouillage du couvercle de la centrifugeuse lors de l'ouverture ou de la fermeture de ce dernier.
- ▶ Ouvrez toujours entièrement le couvercle de la centrifugeuse afin qu'il ne puisse pas se refermer.



**AVERTISSEMENT ! Risque de blessure lors de l'utilisation de ressort(s) pneumatiques défectueux.**

Un ressort pneumatique défectueux ne supporte pas suffisamment le couvercle de la centrifugeuse. Les doigts ou les membres du corps peuvent être écrasés.

- ▶ Vérifiez que le couvercle de la centrifugeuse peut être entièrement ouvert et demeure dans cette position.
- ▶ Contrôlez régulièrement si les ressorts pneumatiques fonctionnent proprement.
- ▶ Faites remplacer immédiatement tout ressort pneumatique défectueux.
- ▶ Faites remplacer les ressorts pneumatiques tous les 2 ans par un technicien du service.



**AVERTISSEMENT ! Risque de blessures suite à des dommages chimiques ou mécaniques des accessoires.**

Même des rayures ou fissures légères peuvent gravement endommager l'appareil.

- ▶ Protégez toutes les pièces mécaniques des accessoires des éventuelles détériorations mécaniques.
- ▶ Avant chaque utilisation, vérifiez que les accessoires ne sont pas endommagés. Remplacez tout accessoire endommagé.
- ▶ N'utilisez pas de rotors, de couvercles de rotor, de nacelles, de flacons ou de couvercles présentant des traces de corrosion ou des dommages mécaniques (par ex. des déformations).
- ▶ N'utilisez pas d'accessoires dont la durée maximale d'utilisation est dépassée.
- ▶ Lors de la mise en place de la nacelle et des rotors, veillez à ne pas rayer les surfaces.



**ATTENTION ! Défauts de sécurité à cause de pièces de rechange et d'accessoires incorrects.**

Des accessoires et des pièces de rechange qui n'ont pas été recommandés par Eppendorf portent atteinte à la sécurité, au fonctionnement et à la fidélité de l'appareil. Eppendorf décline toute garantie et responsabilité des dommages causés par des pièces de rechange et des accessoires non recommandés ou par une utilisation inappropriée.

- ▶ Utilisez seulement des accessoires recommandés par Eppendorf et des pièces de rechange d'origine.



**AVIS ! Dommages de l'appareil causés par des liquides agressifs déversés.**

1. Déclenchez l'appareil.
2. Débranchez la prise électrique de l'appareil.
3. Procédez à un nettoyage soigneux de l'appareil et des accessoires selon les instructions de nettoyage et de désinfection indiquées dans le manuel d'utilisation.
4. Si vous désirez utiliser une autre méthode de nettoyage et de désinfection, veuillez-vous assurer auprès d'Eppendorf AG que la méthode ne constitue aucun risque pour l'appareil.



**AVIS ! Dommages aux composants électroniques dus à la formation de condensation.**

Après avoir transporté l'appareil d'un environnement froid dans un environnement plus chaud, il se peut que du condensat se forme dans l'appareil.

- ▶ Après avoir déposé l'appareil, attendre au moins pendant 4 h. Brancher l'appareil au secteur seulement après.



**AVIS ! Amortissement des béciers dans la mauvaise direction.**

Lorsque de mauvais adaptateurs sont utilisés pour les cuves Corning 500 mL, les béciers du rotor libre peuvent s'amortir dans la mauvaise direction. Le mauvais amortissement des béciers peut conduire à une perte des échantillons ou un endommagement de la centrifugeuse.

- ▶ Utilisez uniquement l'adaptateur Eppendorf prévu pour les cuves Corning 500 ml.

## 2.5.2 Manipulation incorrecte de la centrifugeuse



### **AVIS ! Dommages dus à un heurt ou à un mouvement de l'appareil en marche.**

Un rotor qui frappe contre la paroi de la cuve risque de causer des dommages importants sur l'appareil et le rotor.

- ▶ Ne déplacez pas et ne heurtez pas l'appareil pendant son fonctionnement.

## 2.5.3 Manipulation incorrecte des rotors



### **AVERTISSEMENT ! Risque de blessures dû à des rotors et des couvercles de rotor non fixés correctement.**

- ▶ Ne centrifugez qu'avec un rotor et un couvercle de rotor bien fixés.
- ▶ Le rotor ou son couvercle ne sont éventuellement pas bien fixés quand des bruits inhabituels apparaissent au lancement de la centrifugeuse. Terminez immédiatement la centrifugation en actionnant la touche **start/stop**.



### **ATTENTION ! Risque de blessure en cas de chargement asymétrique du rotor.**

- ▶ Remplissez les rotors de manière symétrique, en utilisant les mêmes types de tubes, de plaques et de nacelles.
- ▶ Les emplacements d'un moteur libre seront toujours tous occupés par les nacelles.
- ▶ Ne chargez les adaptateurs qu'avec les tubes et les plaques adéquats.
- ▶ Utilisez toujours des tubes et des plaques de même type (poids, matériau/densité et volume).
- ▶ Vérifiez que le chargement est symétrique en effectuant un tarage des adaptateurs, tubes ou plaques utilisés à l'aide d'une balance.



### **ATTENTION ! Risque d'accident dû à une surcharge du rotor.**

La centrifugeuse est conçue pour la centrifugation de produits dont la densité max. est de 1,2 g/mL à vitesse de rotation max., avec un volume de remplissage max. ou un chargement max.

- ▶ Ne dépassez pas le chargement maximum du rotor.



**ATTENTION ! Risque de blessure par couvercles de rotor ou capuchons chimiquement endommagés.**

Les couvercles de rotor ou capuchons transparents en PC, PP ou PEI peuvent perdre de leur rigidité sous l'action de solvants organiques (p. ex phénol, chloroforme).

- ▶ Lorsque des couvercles de rotor ou capuchons sont entrés en contact avec des solvants organiques, nettoyez-les immédiatement.
- ▶ Contrôlez régulièrement l'absence de dommages et de fissures sur les couvercles de rotor ou les capuchons.
- ▶ Remplacez immédiatement les couvercles de rotor ou les capuchons présentant des fissures ou des colorations laiteuses.



**AVIS ! Risque d'endommagement des rotors par des produits chimiques agressifs.**

Les rotors sont des composants de haute qualité qui résistent à des contraintes extrêmes. Cette stabilité peut être compromise par des produits chimiques agressifs.

- ▶ Évitez d'utiliser des produits chimiques agressifs, parmi lesquels entre autres les alcalins forts et faibles, les acides forts, les solutions contenant des ions de mercure, cuivre et autres métaux lourds, les hydrocarbures halogénés, les solutions salines concentrées et le phénol.
- ▶ En cas de pollution par des produits chimiques agressifs, nettoyez immédiatement le rotor avec un détergent neutre. Cela concerne en particulier les alésages.
- ▶ Pour les rotors marqués "coated", des différences de couleur peuvent apparaître en raison du processus de fabrication. Cela n'a aucune influence sur la durabilité ou la résistance aux produits chimiques.



**AVIS ! Le rotor peut tomber lorsqu'il n'est pas manipulé correctement.**

Le rotor libre risque de tomber si les nacelles sont utilisées comme poignées.

- ▶ Retirez les nacelles avant de mettre en place / retirer le rotor.
- ▶ Portez toujours le rotor en croisillon avec les deux mains.



**AVIS ! Le rotor peut tomber lorsqu'il n'est pas manipulé correctement.**

- ▶ Saisissez toujours le rotor F-35-48-17 des deux mains.
- ▶ Pour tenir le rotor de manière sûre, retirez 3 ou 4 douilles face-à-face de la rangée extérieure.

## 2.5.4 Contrainte extrême des tubes de centrifugation



### **ATTENTION ! Risque d'accident dû à des tubes surchargés.**

- ▶ Tenez compte des valeurs limite spécifiées par le fabricant quant à la charge admissible des tubes.
- ▶ N'utilisez que des tubes autorisés par le fabricant pour les nombres  $g$  (rcf) désirés.



### **AVIS ! Risque dû à des tubes endommagés.**

Les tubes endommagés ne doivent pas être utilisés. Il peut s'en suivre des dommages supplémentaires sur l'appareil et ses accessoires, ainsi que des pertes d'échantillons.

- ▶ Effectuez un contrôle visuel de tous les tubes pour détecter tout dommage avant l'utilisation.



### **AVIS ! Dommage matériel causé par un couvercle de tube ouvert.**

Les couvercles de tubes ouverts pendant la centrifugation peuvent se casser et endommager le rotor ainsi que la centrifugeuse.

- ▶ Fermez soigneusement tous les couvercles des tubes avant de procéder à la centrifugation.



### **AVIS ! Risque d'endommagement des tubes en plastique par des solvants organiques.**

L'utilisation de solvants organiques (tels que phénol, chloroforme) réduit la solidité des tubes en plastique, si bien que ces derniers peuvent être endommagés.

- ▶ Tenez compte des indications du fabricant sur la stabilité chimique des tubes.



### **AVIS ! Les récipients de réaction se réchauffent.**

Dans les centrifugeuses non réfrigérées, la température de la cuve de rotor peut monter à plus de 40 °C selon le temps de cycle, le facteur  $g$  (rcf) / vitesse de rotation et la température ambiante.

- ▶ Observez la baisse de résistance des récipients de réaction qui en résulte.
- ▶ Tenez compte de la résistance aux chocs thermiques des échantillons.

## 2.5.5 Centrifugation anti-aérosols



### **AVERTISSEMENT ! Risque pour la santé lié à une étanchéité aux aérosols limitée lorsque le couvercle et le rotor sont mal combinés.**

La centrifugation anti-aérosols est garantie uniquement si les rotors et couvercles de rotor prévus à cet effet sont utilisés. Pour les rotors angulaires anti-aérosols, la désignation commence toujours par **FA**. Les rotors et les couvercles de rotor anti-aérosols de cette centrifugeuse sont repérables par une bague rouge supplémentaire sur le rotor et par une vis rouge sur le couvercle du rotor.

Les rotors libres anti-aérosols portent la désignation **AT** (aerosol-tight).

- ▶ Pour la centrifugation anti-aérosols, utilisez toujours simultanément des rotors et couvercles de rotor désignés comme anti-aérosols dans la centrifugeuse prévue. L'indication de la centrifugeuse dans laquelle les rotors et couvercles de rotor anti-aérosols peuvent être utilisés figure sur le rotor et pour ceux produits après octobre 2003 sur la face supérieure du couvercle de rotor.
- ▶ Utilisez des couvercles de rotor anti-aérosols uniquement en association avec les rotors mentionnés sur le couvercle de rotor.
- ▶ Utilisez les flacons anti-aérosols uniquement en association avec les couvercles correspondants.







### **AVERTISSEMENT ! Risque pour la santé lié à une étanchéité aux aérosols limitée en cas de mauvaise utilisation.**

L'autoclavage, les sollicitations mécaniques et les contaminations dues aux produits chimiques ou autres solutions agressives peuvent altérer l'étanchéité aux aérosols des rotors et de leur couvercle.

- ▶ Contrôlez après chaque utilisation l'intégrité des joints des couvercles de rotor ou capuchons anti-aérosols.
- ▶ N'utilisez que des couvercles de rotor ou capuchons anti-aérosols dont les joints sont propres et en parfait état.
- ▶ Après chaque autoclavage effectué dans les règles de l'art (121 °C, 20 min.), graissez légèrement les chevilles se trouvant dans la vis du couvercle de rotor avec de la graisse pour tourillons. (N° de commande Int. 5810 350.050, Amérique du Nord 022634330).
- ▶ Remplacez le couvercle de rotor et les capuchons anti-aérosols tous les 50 cycles d'autoclavage.
- ▶ Sur les couvercles de rotor QuickLock, le joint doit être remplacé tous les 50 cycles d'autoclavage.
- ▶ Ne stockez **jamais** les rotors et les béciers anti-aérosols fermés.

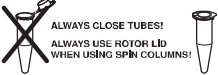
## 2.6 Consignes de sécurité sur l'appareil

Représentation	Signification	Emplacement
	<b>Zone dangereuse</b> <ul style="list-style-type: none"> <li>▶ respecter le manuel d'utilisation.</li> </ul>	Côté droit de l'appareil
	<b>ATTENTION</b> <ul style="list-style-type: none"> <li>▶ Serrer toujours le rotor avec la clé de rotor fourni.</li> </ul>	Partie supérieure de l'appareil sous le couvercle de la centrifugeuse.
	<b>ATTENTION</b> <ul style="list-style-type: none"> <li>▶ Fermer toutes les cuves.</li> <li>▶ Utiliser le couvercle de rotor.</li> </ul>	Partie supérieure de l'appareil sous le couvercle de la centrifugeuse.
	Avertissement contre les risques biologiques lors du maniement de liquides infectieux ou de germes pathogènes.	Rotors/couvercle de rotor anti-aérosols, béciers/capuchons anti-aérosols.



### 3 Désignation

#### 3.1 Aperçu des produits

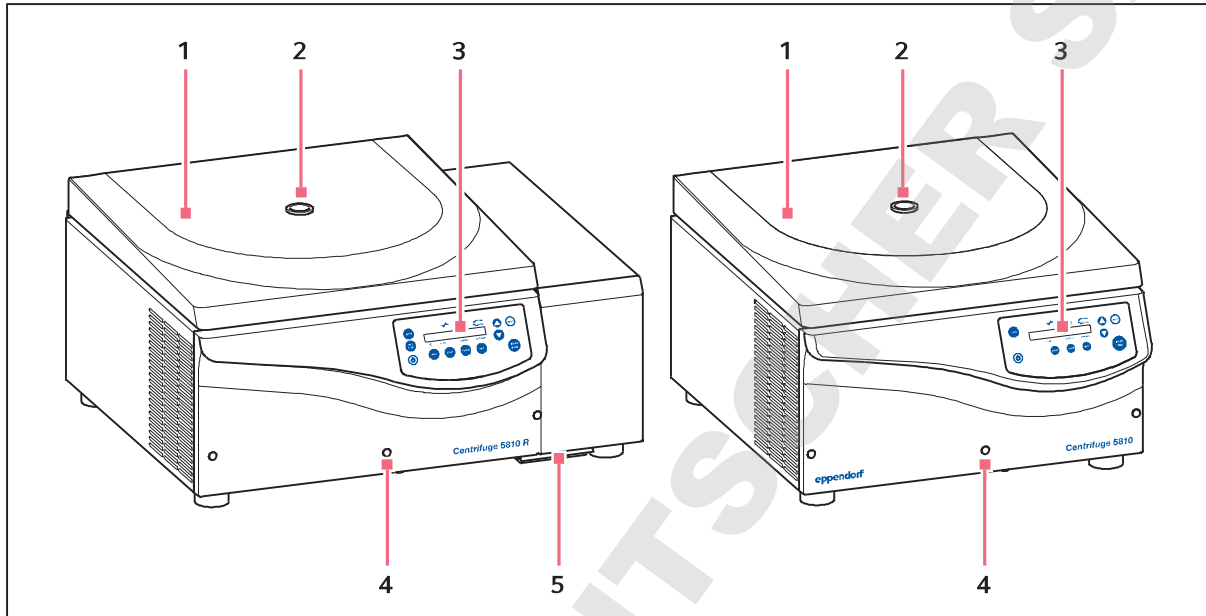

Fig. 3-1: Centrifuge 5810 R et Centrifuge 5810. Les Centrifuge 5804 R et Centrifuge 5804 sont de type similaire.

- |   |  |
|---|--|
| <b>1 Couvercle de la centrifugeuse</b>  | <b>4 Déverrouillage d'urgence</b><br>(voir <i>Déverrouillage de secours</i> à la page 151) |
| <b>2 Fenêtre de contrôle</b><br>Contrôle visuel de l'arrêt du rotor ou contrôle de la vitesse de rotation à l'aide d'un stroboscope | <b>5 Coupelle d'eau de condensation (uniquement Centrifuge 5804 R/5810 R)</b>              |
| <b>3 Commandes et écran</b><br>(voir <i>Commandes</i> à la page 129)  |  |

## 4 Installation

### 4.1 Sélectionner un emplacement



**AVIS ! En cas de défaut, risque de dommages aux objets situés à proximité immédiate de l'appareil.**

- ▶ Selon les recommandations de la norme EN 61010-2-020, laissez un espace de sécurité de **30 cm** autour de l'appareil pendant le fonctionnement.
- ▶ Retirez tous les matériaux et objets se trouvant dans cette zone.



**AVIS ! Dommages à cause de surchauffe.**

- ▶ Ne pas installer l'appareil près de sources de chaleur (p. ex. chauffages, étuves).
- ▶ Ne pas exposer l'appareil directement au soleil.
- ▶ Garantir une circulation d'air libre. Ne pas encombrer l'espace autour des grilles d'aération à une distance minimale de 30 cm.



**AVIS ! Perturbations radioélectriques.**

Cet appareil est un produit de la classe A selon EN 55011. Dans des zones d'habitation, il se peut que la réception des radiocommunications soit perturbée.

- ▶ Prenez des mesures protectrices appropriées.

Choisissez l'emplacement de l'appareil selon les critères suivants :

- branchement sur le secteur comme indiqué sur la plaque d'identification
- Table sans résonance à surface de travail horizontale plane
- L'emplacement est bien ventilé.
- L'emplacement est protégé du rayonnement solaire direct.

### 4.2 Préparer l'installation



**ATTENTION ! Risque de blessures par suite de soulever et porter des charges lourdes**

L'appareil est lourd. Soulever et porter l'appareil peut entraîner des maux de dos.

- ▶ Pour transporter et soulever l'appareil, garantir un nombre suffisant d'assistants.
- ▶ Pour le transport, utiliser un support de transport.

Procédez aux étapes suivantes en respectant l'ordre indiqué :

1. Ouvrez le carton d'emballage.
2. Ôtez le carton de couverture.
3. Retirez les accessoires.
4. Soulevez l'appareil par le bas, à proximité des pieds en caoutchouc et déposez-la directement sur une paillasse appropriée.

### 4.3 Installation de l'appareil



**AVERTISSEMENT ! Danger à cause d'une tension d'alimentation inappropriée.**

- ▶ Branchez l'appareil seulement à des sources de courant qui correspondent aux exigences électriques indiquées sur la plaque d'identification.
- ▶ Utilisez seulement des prises de courant avec terre et des câbles secteur appropriés.



**AVIS ! Centrifuge 5804 R/5810 R: Risque d'endommagement du compresseur en cas de procédure de transport inappropriée.**

- ▶ Mettez la centrifugeuse sous tension seulement 4 heures après l'avoir mise en place.

1. Laisser l'appareil se réchauffer pendant au moins 3 heures (5804/5810) ou 4 heures (5804 R/5810 R) à température ambiante, afin d'éviter tout endommagement des composants électroniques par la condensation et endommagement du compresseur (seulement 5804 R/5810 R).
2. Vérifier que la tension et la fréquence du courant concordent avec celles indiquées sur la plaque signalétique de l'appareil.  
Centrifuge 5804 R/5810 R avec tension du courant 120 V : observer les remarques sur l'alimentation électrique à la fin de ce chapitre.
3. Brancher la centrifugeuse sur le secteur et la mettre en marche à l'aide de l'interrupteur général se trouvant sur le côté droit de l'appareil.
  - La touche **open** est allumée.
  - L'écran est allumé.
4. Ouvrir le couvercle de la centrifugeuse avec la touche **open**.
5. Vérifier que la livraison est complète en se référant aux données concernant les pièces incluses dans la livraison.
6. Vérifier qu'aucune pièce de l'appareil n'a été endommagée lors du transport. En cas de dommage, veuillez-vous adresser à votre distributeur.
7. **Uniquement 5804 R/5810 R** : Pousser la coupelle d'eau de condensation se trouvant sur l'avant de l'appareil dans le support prévu à cet effet

**Installation**

Centrifuge 5804/5804 R/5810/5810 R  
Français (FR)

Tab. 4-1: Centrifuge 5804 R/5810 R avec tension du courant 120 V en deux versions

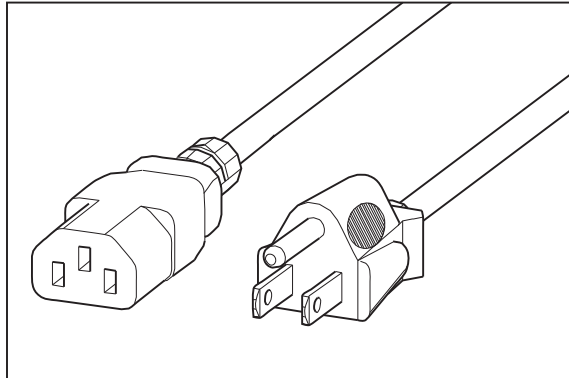
**Cordon d'alimentation CEI 15 A**

- Cordon d'alimentation CEI conventionnel.
- Raccord à la prise de courant avec terre standard (120 V/15 A).
- Puissance frigorifique standard :
  - températures minimales accessibles augmentées à vitesse de centrifugation maximale.
  - Lent refroidissement à la température de consigne.

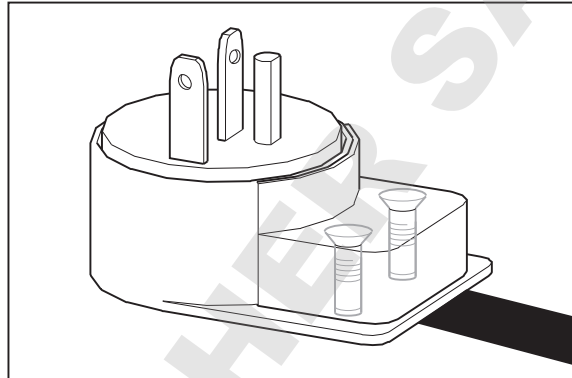
**Version 20 A**

- Câble secteur monté de manière fixe sur l'appareil.
- Nécessité d'un branchement spécial sur le secteur (120 V/20 A).
- Puissance frigorifique augmentée.
  - Possibilité de températures plus basses à vitesse de centrifugation maximale.
  - Refroidissement plus rapide à la température de consigne.

DOMINIQUE DUTREUIL SAS

## 5 Utilisation

### 5.1 Commandes

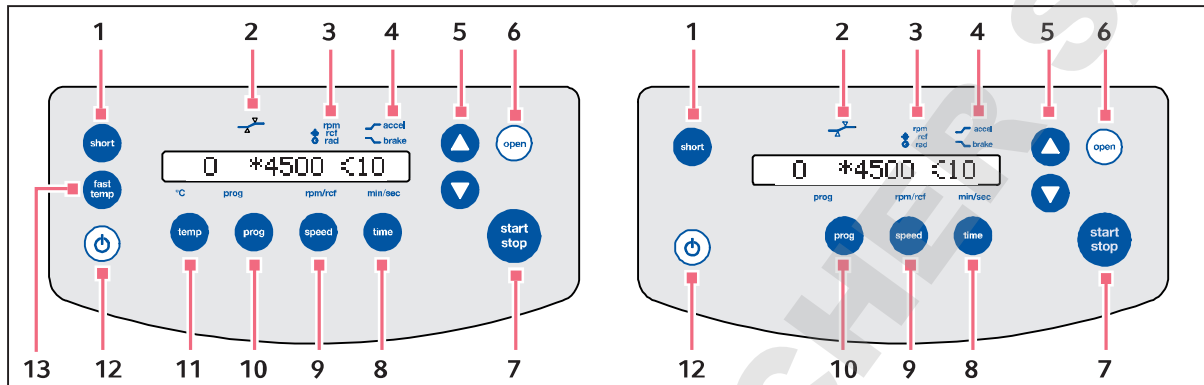

Fig. 5-1: Commandes Centrifuge 5804 R/5810 R et Centrifuge 5804/5810

- 1 Touche short**  
Centrifugation de courte durée
- 2 Statut de la fonction At set rpm**  
↗: la minuterie commence à 95 % du nombre de  $g$  (rcf) ou de la vitesse (rpm) prescrite.  
↘: la minuterie commence immédiatement.
- 3 Désignation de la vitesse de rotation (tr/min), nombre de  $g$  (rcf) \* et réglage du rayon Ⓞ.**
- 4 Symbole de départ ↗ et freinage ↘**
- 5 Touches fléchées**  
Réglage des paramètres et valeurs  
Touche fléchée maintenue appuyée : réglage rapide
- 6 Touche open**  
Déverrouillage du couvercle
- 7 Touche start/stop**  
Démarrage et arrêt de la centrifugation
- 8 Touche time**  
Sélection du réglage du temps de fonctionnement  
Réglage de la durée de la centrifugation avec les touches fléchées
- 9 Touche speed**  
Sélection de la vitesse de centrifugation et réglage avec les touches fléchées
- 10 Touche prog**  
Pression sur la touche **prog** : chargement de programme  
Touche **prog** maintenue appuyée pendant 2 s : enregistrement des paramètres actuels
- 11 Touche temp**  
**Uniquement 5804 R/5810 R** : Sélection de la température et réglage avec les touches fléchées
- 12 Touche Standby Ⓞ**  
La LED est allumée en vert : la centrifugeuse est opérationnelle  
La LED est allumée en rouge : le mode veille est actif
- 13 Touche fast temp**  
**Uniquement 5804 R/5810 R** : Démarrage de la thermostatisation FastTemp

**Utilisation**

Centrifuge 5804/5804 R/5810/5810 R  
Français (FR)

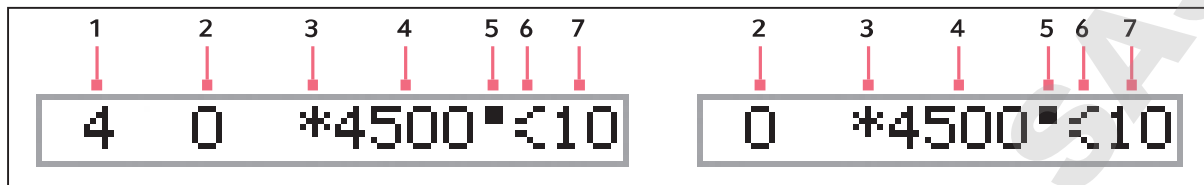

Fig. 5-2: Écran Centrifuge 5804 R/5810 R et Centrifuge 5804/5810

- |   |   |
|---|---|
| 1 Uniquement 5804 R/5810 R : Température        | 5 Le symbole clignote pendant la centrifugation |
| 2 Numéro de programme                           | 6 Symbole de départ ↗ et freinage ↘             |
| 3 Symbole du nombre de $g$ (rcf)                | 7 Durée de la centrifugation                    |
| 4 Nombre de $g$ (rcf)/vitesse de rotation (rpm) |   |

#### Indication de la valeur réelle et de la valeur de consigne

- Arrêt du rotor : affichage des valeurs de consigne
- Centrifugation : affichage des valeurs réelles

**Affichage de la valeur de consigne pendant la centrifugation** : appuyer sur les touches **temp**, **time** ou **speed**. La valeur de consigne s'affiche pendant 2,5 s.

## 5.2 Préparation à la centrifugation

### 5.2.1 Mise en marche de la centrifugeuse

1. Enclenchez la centrifugeuse avec l'interrupteur général ou la touche standby ☉.
2. Ouvrez le couvercle de la centrifugeuse fermé en appuyant sur la touche **open**.  
Le paramétrage du dernier run est affiché.

### 5.2.2 Mise en place du rotor

#### Prérequis

Lors de la fixation et du débloquage du rotor sur l'arbre du moteur, la température du rotor et de l'arbre du moteur doit se situer entre 10 et 30 °C.



**AVIS ! Le rotor peut tomber lorsqu'il n'est pas manipulé correctement.**

- ▶ Saisissez toujours le rotor F-35-48-17 des deux mains.
- ▶ Pour tenir le rotor de manière sûre, retirez 3 ou 4 douilles face-à-face de la rangée extérieure .



- ▶ **Rotors libres:** Retirez les nacelles avant de retirer le rotor. Saisissez toujours le croisillon du rotor des deux mains.

1. Placez le rotor à la perpendiculaire sur l'arbre du moteur.
2. Enfoncez la clé du rotor dans l'écrou de ce dernier.

**Rotor en croisillon A-4-81/S-4-104:** utiliser une clé du rotor spécifique.

3. Faites tourner la clé **dans le sens des aiguilles d'une montre** jusqu'à ce que l'écrou soit bien fixé.

### 5.2.3 Reconnaissance automatique du rotor

Pour déclencher la reconnaissance du rotor,

- ▶ Maintenir enfoncée la touche **start/stop** avec le couvercle de la centrifugeuse ouvert et tourner le rotor à la main en sens inverse horaire.  
L'affichage indique la vitesse de rotation maximale du rotor. le facteur g (rcf) et la vitesse de rotation (tr / min) sont automatiquement limités à la valeur maximale autorisée pour le rotor.
- ▶ Contrôler le réglage **At set rpm**.

### 5.2.4 Rotor chargé



**ATTENTION ! Risque de blessure en cas de chargement asymétrique du rotor.**

- ▶ Remplissez les rotors de manière symétrique, en utilisant les mêmes types de tubes, de plaques et de nacelles.
- ▶ Les emplacements d'un rotor libre seront toujours tous occupés par les nacelles.
- ▶ Ne chargez les adaptateurs qu'avec les tubes et les plaques adéquats.
- ▶ Utilisez toujours des tubes et des plaques de même type (poids, matériau/densité et volume).
- ▶ Vérifiez que le chargement est symétrique en effectuant un tarage des adaptateurs, tubes ou plaques utilisés à l'aide d'une balance.



Pendant le fonctionnement, l'appareil identifie automatiquement les balourds et termine immédiatement le run avec un message d'erreur et un signal avertisseur.

- ▶ Contrôlez la charge, tarez les tubes et relancez le run.

### 5.2.4.1 Rotors angulaires



#### Couvercle de rotor

- Les rotors angulaires ne doivent être utilisés qu'avec le couvercle adapté. Pour utiliser les couvercles de rotor appropriés, il faut vérifier si les marquages du nom du rotor sur le rotor et sur son couvercle sont identiques.
- Pour effectuer une centrifugation anti-aérosols, utilisez un rotor anti-aérosols en liaison avec le couvercle du rotor correspondant.

Pour charger le rotor, procédez de la manière suivante :

1. Contrôlez le chargement maximal (adaptateur, tube et contenu) pour chaque alésage de rotor. Vous trouverez les informations à ce sujet sur le rotor et dans ce manuel d'utilisation .
2. Ne chargez les rotors et les adaptateurs qu'avec les tubes prévus à cet effet.
3. Placez les tubes par paires face à face dans les alésages du rotor. Pour que le chargement soit symétrique, les tubes qui se font face doivent être de même type et contenir la même quantité de substance.

Afin de limiter les différences de poids entre les microtubes d'échantillonnage remplis, il est conseillé de tarer avec une balance. Cela permet de protéger l'entraînement et de réduire les bruits de fonctionnement.

4. Posez le couvercle de rotor et fixez-le.

### 5.2.4.2 Rotors libres

Prérequis

- Une association de rotor, nacelle et adaptateur agréée par Eppendorf.
- Les nacelles sont classées d'après leur poids. Les nacelles placées les unes en face des autres doivent appartenir à la même catégorie. La classe de poids est gravée dans la rainure, par. ex. 68 (en grammes). Lors des commandes - même des nacelles pour plaques - veuillez toujours indiquer la catégorie du poids.
- Tubes et plaques adaptés et agréés.
- Ne retirez pas les éléments de guidage intermédiaires des adaptateurs modulaires prévus pour les béciers carrés, afin d'augmenter par ex. la capacité en procédant à une centrifugation étagée.



#### **AVIS ! Tout empilage incorrect risque d'endommager les adaptateurs**

- ▶ Placez les adaptateurs dans les flacons carrés uniquement dans une rangée fermée, de bas en haut. Ne laissez pas d'espace entre les modules.



#### **AVIS ! Ne pas trop remplir les plaques pour éviter les débordements.**

Durant la centrifugation, les ménisques des tubes placés au bord des plaques sont inclinés. Ceci est dû à la force centrifuge qui est inévitable.

- ▶ Remplissez les puits des plaques au 2/3 max. de leur capacité max.



Pour charger le rotor, procédez de la manière suivante :

1. Contrôlez si les rainures des nacelles sont propres et graissez-les légèrement avec de la graisse à pivots (code &nbsp;: 5810 350.050 / Amérique du Nord : 022634330).  
Les rainures et tourillons encrassés empêchent un balancement homogène de la nacelle.
2. Accrocher la nacelle dans le rotor.  
Les positions du rotor doivent toutes être occupées.
3. Vérifiez que les nacelles sont toutes bien suspendues et qu'elles peuvent se balancer librement.

**Assurer un bon amortissement**

4. Afin de vérifier que les flacons, plaques ou tubes s'amortissent sans obstacle et que les béciers ou les nacelles s'amortissent manuellement.

**Vérifier la direction d'amortissement.**

5. Afin de vérifier que les béciers / nacelles, chargement compris, s'amortissent en direction de la paroi de la cuve de rotor, tourner le rotor en croisillon en sens inverse des aiguilles d'une montre.
6. Contrôlez la charge maximum admissible par nacelle (adaptateur, tube ou plaque avec contenu) et la hauteur de la charge.  
Vous trouverez les informations à ce sujet sur le rotor et dans ce manuel d'utilisation.
7. Chargez le rotor symétriquement.

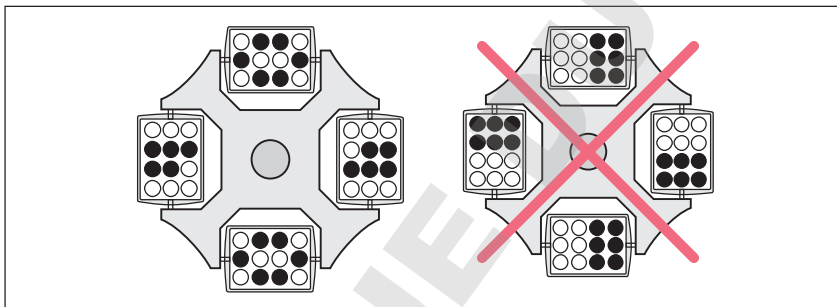

Fig. 5-3: Chargement incomplet mais symétrique du bécier. Les rainures de chaque bécier doivent être chargées de manière uniforme.

Le chargement de plaque représenté sur la page de droite est incorrect, étant donné que les nacelles ne peuvent pas se balancer correctement.

Le même principe vaut également pour la mise en place de 4 plaques sur le rotor A-4-81-MTP/Flex.

Les plaques ont un léger jeu dans les nacelles.

8. Contrôlez le chargement de la nacelle.

**Utilisation**

Centrifuge 5804/5804 R/5810/5810 R  
Français (FR)

**5.2.4.3 Rotor S-4x750 : garnissez l'adaptateur avec des récipients de > 119 mm de long****AVIS ! Rupture du verre en cas de garnissage incorrect.**

Si un béccher est garni de récipients trop longs, le récipient entrera en contact avec le rotor en croisillon pendant l'amortissement et risquera d'être endommagé ou détruit.

- ▶ Garnissez toujours les bécchers des rotors libres de manière à assurer la liberté des mouvements.
- ▶ Le cas échéant, ne garnissez que les trous intérieurs de l'adaptateur.
- ▶ Lors de l'utilisation de récipients d'une longueur > 100 mm : effectuez toujours un test d'amortissement manuel.

Si l'adaptateur 16 × 75 mm – 100 mm (N° de commande 5825 736.001) est garni de récipients d'une longueur > 119 mm, par ex. BD 8 mL Vacutainer, le verre risque de se briser.

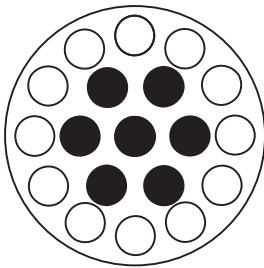

Fig. 5-4: Garnissage de l'adaptateur 16 × 75 - 100 mm avec des tubes de >119 mm de longueur.

- ▶ Ne garnissez que les alésages intérieurs.

**5.2.4.4 Garnissage mixte avec bécchers et nacelles de plaques**

Le rotor libre ne peut recevoir un garnissage mixte avec bécchers et nacelles de plaques que s'ils conviennent au rotor. Les bécchers ou nacelles de plaques positionnés les uns en face des autres doivent être des bécchers/nacelles de plaque du même type.

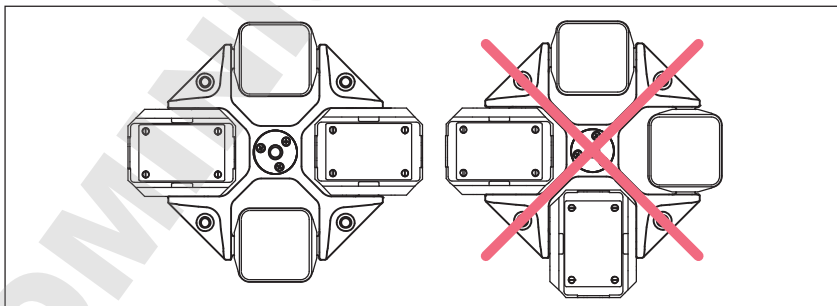

Fig. 5-5: Équipement mixte des rotors

Rotor	Garnissage mixte
S-4-104	<ul style="list-style-type: none"><li>• 2 nacelles à plaques (nacelles ouvertes ou bécher à plaque)</li><li>• 2 béciers ronds</li></ul>
A-4-81/A-4-81-MTP/Flex	<ul style="list-style-type: none"><li>• 2 nacelles à plaques (nacelles MTP ou DWP)</li><li>• 2 béciers pour tubes coniques</li><li>• 2 béciers carrés</li></ul>
A-4-44	<ul style="list-style-type: none"><li>• 2 béciers carrés</li><li>• 2 béciers pour tubes coniques</li></ul>



**AVIS ! Endommagement du rotor en raison d'un équipement mixte.**

Lorsque vous chargez les rotors A-4-62 et A-4-62-MTP avec un équipement mixte, les rotors sont endommagés lors de la centrifugation.

- ▶ Équipez les rotors A-4-62 et A-4-62-MTP des mêmes nacelles sur tous les emplacements.
- ▶ En cas de rotors libres, équipez toujours les 4 emplacements.

- ▶ Contrôlez le chargement de la nacelle.

### 5.2.5 Fermeture du couvercle de la centrifugeuse

1. Contrôlez la bonne fixation du rotor et de son couvercle.
2. Rabaissez le couvercle de la centrifugeuse jusqu'à ce que le système de verrouillage du couvercle s'enclenche et que le couvercle se ferme automatiquement.

La centrifugeuse se ferme automatiquement.

La touche **open** s'allume en bleu. L'affichage indique le symbole ■.

**Utilisation**

Centrifuge 5804/5804 R/5810/5810 R  
Français (FR)

**5.3 Refroidissement (seulement 5804 R/5810 R)****5.3.1 Réglage de la température**

- ▶ Réglez la température à l'aide de la touche **temp**.
- ▶ Réglez la température avec les touches fléchées de -9 °C à +40 °C.

**5.3.2 Affichage de la température**

À l'arrêt du rotor :                      Température définie

Pendant la centrifugation :            Température réelle

**5.3.3 Contrôle de la température**

Une fois que la température définie est atteinte, la centrifugeuse réagit de la manière suivante aux variations de température pendant la centrifugation :

Écart par rapport à la valeur de consigne	Action
± 3 °C	Les températures clignotent sur l'affichage.
± 5 °C	Avertisseur sonore périodique. La centrifugation est terminée automatiquement.

**5.3.4 FastTemp**

Cette fonction vous permet de démarrer directement la thermostatisation sans échantillons à la vitesse spécifique du rotor et définie pour la température, afin d'amener rapidement la cuve du rotor avec le rotor, la nacelle et l'adaptateur à la température définie à préalable.

**Prérequis**

- La centrifugeuse est enclenchée.
- Le rotor et le couvercle du rotor sont correctement fixés.
- Le couvercle de la centrifugeuse est fermé.
- La température et le facteur g (rcf)/vitesse de rotation (tr/min) de la centrifugation qui va suivre sont réglés (voir *Centrifugation à la page 138*).



**1. Appuyez sur la touche **fast temp**.**

À l'écran apparaissent de gauche à droite : Température réelle, *FT*, facteur g (rcf) / vitesse de rotation (tr/min) und -- (heure).

La thermostatisation s'arrête automatiquement une fois atteinte la température définie. Une alarme périodique se produit.

**2. Appuyez sur la touche **start/stop**, pour interrompre prématurément la thermostatisation.**

Après avoir atteint la température définie et une fois la thermostatisation terminée, la centrifugeuse maintient la cuve du rotor à la température définie à condition que le couvercle de la centrifugeuse soit fermé et si la température est inférieure à la température ambiante. Quelle que soit la température définie, la centrifugeuse ne passera pas au-dessous de 4 °C pendant cette réfrigération continue afin d'empêcher la cuve du rotor de geler.

-  La centrifugeuse termine automatiquement le run si le rotor ou la nacelle sont entièrement thermostatisés. C'est pourquoi, il peut y avoir un décalage d'environ entre l'affichage de la température de consigne et l'arrêt de la thermostatisation.
-  Lors de l'utilisation de béciers anti-aérosols, effectuez un FastTemp-Run à basse température, sans couvercle. Sinon, les couvercles risquent d'être bloqués sous l'effet d'une dépression. Ne tirez pas sur les clips de fermeture ou les crochets pour détacher le capuchon. Thermostatiser les béciers à température ambiante de manière à pouvoir retirer facilement les couvercles.

### 5.3.5 Réfrigération continue

Lorsque le rotor est arrêté, la cuve de rotor est maintenue à la température définie tant que les conditions suivantes sont réunies :

- La centrifugeuse est enclenchée.
- Le couvercle de la centrifugeuse est fermé.
- La température définie est inférieure à la température ambiante.
- La centrifugeuse n'est pas en mode standby.

Ce qui suit vaut durant une réfrigération continue :

- Les températures définie et réelle sont affichées alternativement.
- Quelle que soit la température définie, la centrifugeuse ne passera pas au-dessous de 4 °C afin d'empêcher la cuve du rotor de geler ainsi qu'une formation excessive d'eau condensée dans l'appareil.
- Comme le rotor ne tourne pas, le réglage de la température se fait plus lentement.

Pour terminer la réfrigération continue, ouvrez le couvercle de la centrifugeuse ou actionnez la touche standby.

Si la centrifugeuse n'est pas utilisée pendant plus de 8 heures, la réfrigération continue est arrêtée automatiquement (ECO shut-off). L'appareil passe alors en mode standby. Cela empêche la formation de glace dans la cuve du rotor ainsi que d'eau condensée excessive dans l'appareil. Avec **FastTemp**, vous pouvez réobtenir rapidement la température souhaitée (voir p. 136).

Après 8 heures, vous pouvez également passer de l'arrêt automatique de la réfrigération continue (ECO shut-off) à la réfrigération continue illimitée.



#### **AVIS ! En cas de réfrigération continue, risque de formation de givre et de surchauffe du compresseur.**

- ▶ Mettez régulièrement la centrifugeuse hors tension afin de faire fondre le givrage éventuel.
- ▶ Retirez régulièrement l'eau de condensation de la chambre du rotor à l'aide d'un chiffon doux et absorbant.
- ▶ Veuillez vider et nettoyer régulièrement le collecteur de condensat.

1. Avec le couvercle de la centrifugeuse ouvert, actionnez simultanément les touches **temp** et **prog**.  
L'affichage indique *Standby 8h*.
2. Appuyez immédiatement sur la touche **fast temp**.  
Le mode de réfrigération continue illimitée est activé. L'affichage indique *Standby endless*.
3. Pour retourner sur la réfrigération *Standby 8h*, répétez le processus.

## Utilisation









Centrifuge 5804/5804 R/5810/5810 R  
Français (FR)

### 5.4 Centrifugation

Quel que soit le modèle de centrifugeuse décrit ici, effectuez les travaux de préparation comme il est décrit précédemment dans (voir *Préparation à la centrifugation à la page 130*).

#### 5.4.1 Centrifugation avec réglage du temps

Procédez aux étapes suivantes en respectant l'ordre chronologique indiqué :

-  1. Réglage de la vitesse (tr/min) : actionnez le bouton une seule fois. Réglage du facteur g (accél.): actionnez plusieurs fois la touche jusqu'à ce que le symbole \* s'affiche. L'affichage du facteur g (accél.)/vitesse (tr/min) clignote et peut être alors modifié à l'aide des touches fléchées. Lors du contrôle du facteur g (accél.), vérifiez également le paramétrage du rayon .
-  2. Réglez le facteur g (accél.)/la vitesse (tr/min) à l'aide des touches fléchées. La nouvelle valeur de consigne apparaît dans l'affichage.
-  3. Sélectionnez le temps de cycle et faites le réglage à l'aide des touches fléchées.
-  4. **Uniquement 5804 R/5810 R** : Sélectionnez la température et faites le réglage à l'aide des touches fléchées.
-  5. Démarrez la centrifugation.
  - Sur l'affichage,  clignote tant que le rotor fonctionne.
  - **Uniquement 5804 R/5810 R** : La température actuelle est affichée.
  - Le facteur g actuel (accél.)/vitesse (tr/min) du rotor est affiché.
  - Vous pouvez afficher toutes les consignes à l'aide d'une touche de paramétrage (**Temp, Speed, Time**) pendant 2,5 s.
  - Vous pouvez terminer prématurément la centrifugation à l'aide de la touche **start/stop**.
  - Une fois le temps écoulé, la centrifugeuse s'arrête automatiquement.
  - Le temps de centrifugation écoulé clignote durant la procédure de freinage.
-  6. Ouvrez le couvercle de la centrifugeuse dès que la touche s'allume.
-  Pendant le run, vous pouvez modifier le temps de cycle total, la température (uniquement Centrifuge 5804 R/5810 R) et le facteur g (accél./la vitesse (tr/mn) ainsi que le temps d'accélération et le temps de freinage. Les nouveaux paramètres sont immédiatement repris. La durée écoulée est calculée sur la base du nouveau temps de cycle total paramétré. Attention : le nouveau temps de cycle total réglable est au moins égal au temps déjà écoulé plus 2 minutes.

#### 5.4.2 Autres possibilités de centrifugations : fonctionnement continu et Short Spin

- ▶ Pour un **fonctionnement continu**, réglez le temps de fonctionnement sur une valeur inférieure à 1 min ou supérieure à 99 min.  
*SH* apparaît sur l'affichage comme symbole.
- ▶ Après avoir refermé le couvercle de la centrifugeuse, démarrez une **centrifugation de courte durée** avec les valeurs maximum ou actuelles du facteur g (accél.)/de la vitesse (tr/min) en actionnant la touche **short**. Pour l'arrêter, relâchez la touche.

### 5.4.3 Retirer le rotor

Prérequis

Lors de la fixation et du déblocage du rotor sur l'arbre du moteur, la température du rotor et de l'arbre du moteur doit se situer entre 10 et 30 °C.



**AVIS ! Le rotor peut tomber lorsqu'il n'est pas manipulé correctement.**

Le rotor libre risque de tomber si les nacelles sont utilisées comme poignées.

- ▶ Retirez les nacelles avant de mettre en place / retirer le rotor.
- ▶ Portez toujours le rotor en croisillon avec les deux mains.



**AVIS ! Le rotor peut tomber lorsqu'il n'est pas manipulé correctement.**

- ▶ Saisissez toujours le rotor F-35-48-17 des deux mains.
- ▶ Pour tenir le rotor de manière sûre, retirez 3 ou 4 douilles face-à-face de la rangée extérieure .

1. Desserrez l'écrou du rotor en le faisant tourner avec la clé dans le sens contraire des aiguilles d'une montre.
2. Retirez le rotor à la verticale par le haut.
3. **Uniquement 5804 R/5810 R** : Une fois les travaux terminés, arrêtez la centrifugeuse et videz le réservoir d'eau condensée. Laissez le couvercle de la centrifugeuse entièrement ouvert et empêchez-le de se refermer.

### 5.4.4 Mode standby

- ▶ Vous pouvez passer du mode veille en mode marche (et vice versa) à tout moment durant une centrifugation en appuyant sur la touche veille.

#### Mode standby

- L'affichage s'éteint.
- La touche veille s'allume en rouge.
- **Uniquement 5804 R/5810 R** : La cuve du rotor n'est pas réfrigérée (voir *Réfrigération continue à la page 137*).

#### État prêt à la marche

- Les paramètres de la centrifugation sont affichés.
- La touche veille s'allume en vert.
- **Uniquement 5804 R/5810 R** : La cuve de rotor est réfrigérée avec le couvercle de la centrifugeuse (voir *Réfrigération continue à la page 137*) fermé.

## 6 Description détaillée et fonction des éléments de commande



### 6.1 Réglage du rayon

Lorsque vous réglez la vitesse en facteur  $g$  (rcf) et non en tr/min (rpm), la conversion interne de la vitesse en facteur  $g$  s'effectue par défaut avec le rayon maximum du rotor utilisé. Vous pouvez adapter ce rayon à l'adaptateur utilisé :

1. Appuyer plusieurs fois jusqu'à ce que le symbole  s'affiche à l'écran.  
Le rayon actuel clignote.
2. Régler un nouveau rayon.
3. Attendre 3 s (à l'arrêt du rotor : 10 s).  
La vitesse en facteur  $g$  modifiée s'affiche.

### 6.2 Réglage des rampes d'accélération et de freinage

Vous pouvez régler les rampes d'accélération et de freinage du niveau 0 à 9. Le niveau 9 est pré-réglé par défaut (rampes d'accélération et de freinage les plus courtes).

1. Appuyer deux fois jusqu'à ce que le symbole  s'affiche.
2. Choisir le niveau d'accélération entre 0 et 9.
3. Appuyer une fois jusqu'à ce que le symbole  pour le niveau de freinage (brake) s'affiche.
4. Choisir le niveau de freinage entre 0 et 9.  
Le niveau de freinage (brake) 0 correspond au freinage en roue libre.

L'appareil affiche en permanence les symboles  et  lorsque les niveaux 0 à 8 sont sélectionnés.

### 6.3 Réglage mode de décompte du temps (At set rpm)

Le temps de centrifugation peut être décompté dès le démarrage de la centrifugeuse ou lorsque 95 % de la valeur de consigne de vitesse (rcf ou rpm) sont atteints (At set rpm). Le réglage correspondant est représenté par le triangle lumineux dans le symbole en haut de l'écran :



Réglage par défaut : le temps est décompté dès le démarrage de la centrifugeuse.



At set rpm : le temps est décompté lorsque 95 % du facteur  $g$  (rcf)/de la vitesse (rpm) réglés sont atteints.

Prérequis

Couvercle ouvert.



- ▶ Afin de commuter entre les deux réglages, maintenir cette touche enfoncée pendant 4 s au minimum,

Lorsque la touche est enfoncée, les deux triangles du symbole clignotent alternativement.







## 6.4 Enregistrer un programme

Vous pouvez enregistrer les paramètres de centrifugation et fonctions en cours (*At set rpm*, rampes d'accélération et de freinage, rayon) parmi 35 numéros de programme disponibles.

Prérequis





Rotor à l'arrêt.

1. Vérifier les paramètres et fonctions à enregistrer.
  2. Appuyer deux fois.  
 Le premier numéro de programme libre s'affiche avec *P...* sur l'affichage.
  3. Sélectionner le numéro de programme (*1...9,A...Z*).  

  4. Maintenir appuyé pendant 2 s.  
 L'affichage indique *ok*. Les paramètres de centrifugation et fonctions en cours sont enregistrés sous le numéro de programme choisi.
-  Si vous voulez écraser un programme enregistré, vous devez le supprimer avant l'enregistrement des nouveaux paramètres (voir *Supprimer un programme à la page 142*).

## 6.5 Charger un programme

Prérequis

- Rotor à l'arrêt.

1. Appuyer une fois.  
 Le numéro de programme clignote :
    - *0*: paramètres de centrifugation et fonctions du dernier cycle.
    - *1...9, A...Z*: programmes enregistrés.
  2. Sélectionner le numéro de programme.  

  3. Si le couvercle de la centrifugeuse est fermé, la centrifugation démarre avec les paramètres de centrifugation et les fonctions chargés.  
 Si le couvercle de la centrifugeuse est ouvert, vous revenez en appuyant sur la touche **start/stop** au programme 0 ou vous quittez le mode de programmation.
-  Lorsque vous modifiez les paramètres de centrifugation pendant un cycle avec un programme enregistré, la centrifugeuse passe au programme 0. Le programme enregistré est quitté sans changement.  
Vous pouvez quitter le programme enregistré également en chargeant le programme 0.

## 6.6 Supprimer un programme

Prérequis

- Rotor à l'arrêt.
- Couvercle de la centrifugeuse ouvert.



1. Appuyer une fois.  
Le numéro de programme clignote.



2. Choisir le numéro de programme.



3. Dans les 10 s, maintenir appuyé pendant 2 s.  
Le message *cleared* s'affiche.  
Le programme sélectionné est supprimé. Vous pouvez enregistrer sous ce numéro de programme de nouveaux paramètres de centrifugation et de nouvelles fonctions.

## 6.7 Fonctions spéciales

### 6.7.1 Affichage des heures d'utilisation

Prérequis

Arrêt du rotor.



- ▶ Appuyer en même temps sur les deux touches.  
L'écran indique le temps de cycle total de la centrifugeuse en heures.

### 6.7.2 Activation/désactivation du signal d'avertissement



- ▶ Appuyer en même temps sur les deux touches pour modifier le réglage.  
Au bout de 2 s, l'écran indique *Alarm on* ou *Alarm off*.

### 6.7.3 Quitter la fonction Service



- ▶ Appuyer en même temps sur les deux touches pour quitter une fonction service ouverte par inadvertance.

## 7 Entretien

### 7.1 Maintenance



#### **AVERTISSEMENT ! Risque de blessure lors de l'utilisation de ressort(s) pneumatiques défectueux.**

Un ressort pneumatique défectueux ne supporte pas suffisamment le couvercle de la centrifugeuse. Les doigts ou les membres du corps peuvent être écrasés.

- ▶ Vérifiez que le couvercle de la centrifugeuse peut être entièrement ouvert et demeure dans cette position.
- ▶ Contrôlez régulièrement si les ressorts pneumatiques fonctionnent proprement.
- ▶ Faites remplacer immédiatement tout ressort pneumatique défectueux.
- ▶ Faites remplacer les ressorts pneumatiques tous les 2 ans par un technicien du service.

Nous recommandons de procéder à la maintenance de la centrifugeuse et des rotors correspondants maximum tous les 12 mois, et de confier ces opérations au service après-vente. Respectez les réglementations en vigueur dans le pays d'utilisation.

### 7.2 Préparation du nettoyage / de la désinfection

- ▶ Au moins une fois par semaine et en cas de fort encrassement, nettoyez les surfaces accessibles de l'appareil et des accessoires.
- ▶ Nettoyez régulièrement le rotor. Cela le protège et augmente sa durée de vie.
- ▶ Par ailleurs, tenez compte des consignes de décontamination (voir *Décontamination avant l'expédition à la page 147*) quand vous expédiez l'appareil pour le faire réparer par le service technique autorisé.

Le déroulement des opérations décrit dans le chapitre suivant concerne non seulement le nettoyage, mais aussi la désinfection et la décontamination. Les opérations également nécessaires sont décrites dans le tableau suivant :

Nettoyage	Désinfection / Décontamination
<ol style="list-style-type: none"><li>1. Pour le nettoyage des surfaces bien accessibles de l'appareil et des accessoires, utilisez un produit nettoyant non agressif.</li><li>2. Procédez au nettoyage comme décrit au chapitre suivant.</li></ol>	<ol style="list-style-type: none"><li>1. Choisissez des méthodes de désinfection conformes aux dispositions légales et aux prescriptions définies pour votre domaine d'application. Utilisez p. e. de l'alcool (éthanol, isopropanol) ou des produits désinfectants à base d'alcool.</li><li>2. Procédez à la désinfection et à la décontamination comme décrit dans le chapitre qui suit.</li><li>3. Nettoyez ensuite l'appareil et les accessoires.</li></ol>



Pour de plus amples informations sur le nettoyage, la désinfection et la décontamination et sur les détergents, veuillez-vous adresser à l'Application Support de Eppendorf AG. Vous trouverez les coordonnées nécessaires au verso de ce manuel d'utilisation.

### 7.3 Nettoyage / désinfection

**DANGER ! Électrocution à cause de liquides pénétrant dans l'intérieur.**

- ▶ Déclencher l'appareil et le débrancher du secteur avant de commencer les travaux d'entretien et de nettoyage.
- ▶ Ne pas laisser pénétrer des liquides dans l'intérieur du boîtier.
- ▶ Ne pas nettoyer le boîtier avec du spray nettoyant ou du spray désinfectant.
- ▶ Brancher l'appareil au secteur seulement quand il est complètement sec à l'intérieur et à l'extérieur.

**AVIS ! Dommages à cause de produits chimiques agressifs.**

- ▶ Ne pas utiliser de produits chimiques agressifs avec l'appareil et ses accessoires comme p. ex. des bases fortes et faibles, des acides forts, de l'acétone, du formaldéhyde, des hydrocarbures halogénés ou du phénol.
- ▶ Si l'appareil est contaminé par des produits chimiques agressifs, le nettoyer immédiatement avec un détergent neutre.

**AVIS ! Corrosion à cause de détergents et de désinfectants agressifs.**

- ▶ Ne pas utiliser ni de détergents caustiques ni de dissolvants agressifs ni de produits de polissage abrasifs.
- ▶ Ne pas incuber les accessoires longtemps dans des détergents ou désinfectants agressifs.

**AVIS ! Dommages à cause du rayonnement UV et d'autres types de rayonnement de haute énergie.**

- ▶ Ne pas effectuer de désinfections au rayonnement UV, bêta ou gamma ou à d'autres hautes énergies.
- ▶ Éviter le stockage dans des zones à fort rayonnement UV.

**Autoclavage**

A l'exception du rotor en croisillon A-4-81, S-4-72 et S-4-104, tous les rotors, couvercles, béciers, nacelles, capuchons et adaptateurs conviennent à l'autoclavage (121 °C, 20 min). Au bout de 50 cycles d'autoclavage maximum, remplacez les capuchons et sur les rotors QuickLock, les joints également.

N'utilisez pas de joints décolorés, poreux ni altérés d'une autre manière. Respectez le manuel d'utilisation de la centrifugeuse et la fiche complémentaire fournie avec les rotors anti-aérosols pour une centrifugation anti-aérosols.

Le rotor anti-aérosols FA-45-30-11 peut être autoclavé pendant 2\*h à 142\*°C afin de détruire les prions. Notez que dans ce cas, le couvercle de rotor doit être remplacé après chaque autoclavage.



### Aerosol-tightness

Avant toute utilisation, vérifiez que les joints soient bien étanches.

Seulement couvercle de rotor QuickLock : Remplacez l'anneau d'étanchéité dans l'écrou du couvercle quand s'il est utilisé.

Remplacez les couvercles de rotor à fermeture à vis lorsque les bagues d'étanchéité sont usées au niveau de la vis du rotor et au niveau de la rainure du couvercle.

Un entretien régulier des bagues d'étanchéité est nécessaire afin de protéger les rotors.

N'entreposez jamais les rotors anti-aérosols avec le couvercle fermé.

Graissez régulièrement et légèrement le filetage des couvercles de rotor étanches aux aérosols pour éviter tout dommage (code Int. : 5810 350.050/Amérique du Nord : 022634330).



### Rotors libres

- Éliminez l'ancienne graisse à pivots au niveau des rainures et des tourillons avant le nettoyage.
- Vérifiez que les rainures et les tourillons sont bien propres. Les rainures et tourillons encrassés empêchent un balancement homogène de la nacelle.
- Après le nettoyage, appliquez une couche fine de graisse pour tourillons sur les tourillons du rotor et les encoches de la nacelle (code commande Int. : 5810 350.050/Amérique du Nord : 022634330) de manière à ce que la nacelle puisse se balancer.

## 7.3.1 Nettoyage / désinfection de l'appareil

1. Ouvrez le couvercle. Éteignez l'appareil avec l'interrupteur général. Débranchez la fiche secteur de l'alimentation électrique.
2. Desserrez l'écrou du rotor en le faisant tourner avec la clé **dans le sens contraire des aiguilles d'une montre**.
3. Retirez le rotor.
4. Essuyez et désinfectez toutes les surfaces accessibles de l'appareil, y compris le câble secteur, à l'aide d'un chiffon humide et des nettoyeurs recommandés.
5. Lavez soigneusement le joint en caoutchouc de la chambre du rotor à l'eau.
6. Enduisez le joint en caoutchouc, une fois sec, de glycérine ou de talc afin d'empêcher qu'il devienne cassant. Les autres pièces de l'appareil, comme par ex. le verrouillage du couvercle, les ressorts, l'arbre moteur et le cône du rotor ne doivent pas être graissés.
7. Nettoyez l'arbre moteur avec un chiffon doux, sec et non pelucheux. Ne pas graisser l'arbre du moteur.
8. Vérifiez que l'arbre du moteur n'est pas endommagé.
9. Vérifiez que l'appareil n'est pas corrodé ni endommagé.
10. Laissez ouvert le couvercle de la centrifugeuse lorsque l'appareil n'est pas utilisé.
11. Ne branchez l'appareil que lorsqu'il est parfaitement sec, à l'intérieur et à l'extérieur.

### 7.3.2 Nettoyage et désinfection du rotor



Après 200 runs, la centrifugeuse affiche 3 fois *clean rotor* afin de vous rappeler le nettoyage régulier du rotor.

1. Contrôlez les traces de corrosion et de dommages sur le rotor et les accessoires. N'utilisez pas de rotors ni d'accessoires endommagés.
2. Nettoyez et désinfectez les rotors et accessoires avec les nettoyeurs recommandés.
3. Nettoyez et désinfectez les alésages du rotor avec un goupillon.
4. Rincez soigneusement à l'eau distillée les rotors et accessoires. Rincez vraiment soigneusement les alésages des rotors angulaires.



Ne plongez pas le rotor dans l'eau. Il ne doit pas pénétrer de liquide dans les interstices.

5. Laissez sécher les rotors et accessoires sur un torchon. Déposez les rotors angulaires, alésages face en bas, pour sécher proprement les alésages.
6. Nettoyez le cône du rotor avec un chiffon doux, sec et non pelucheux. Ne graissez pas le cône du rotor.
7. Vérifiez que le cône du rotor n'est pas endommagé.
8. Posez le rotor sec sur l'arbre du moteur.
9. Vissez l'écrou du rotor en le faisant tourner avec la clé **dans le sens des aiguilles d'une montre**.
10. Équipez le rotor angulaire, si nécessaire, avec des adaptateurs propres ; le rotor libre avec des nacelles et des adaptateurs propres.
11. Laissez ouvert le couvercle de rotor lorsque ce dernier n'est pas utilisé.

### 7.4 Consignes d'entretien supplémentaires pour les centrifugeuses refroidies

- ▶ Videz et nettoyez régulièrement la coupelle d'eau de condensation, particulièrement après le déversement de liquide dans la cuve de la centrifugeuse. Retirez la coupelle d'eau de condensation de la partie avant droite en dessous de l'appareil.
- ▶ Nettoyez régulièrement la conduite d'évacuation d'eau de condensation, par ex. avec un rince-bouteilles.
- ▶ Enlevez régulièrement la glace qui s'est formée dans la cuve de la centrifugeuse en la laissant fondre. Laissez le couvercle ouvert ou effectuez un court cycle de thermostatisation à environ 30 °C à cet effet.
- ▶ Pour ne pas solliciter le(s) ressort(s) pneumatique(s) du couvercle de la centrifugeuse outre mesure, laissez le couvercle ouvert si l'appareil n'est pas utilisé pendant un certain temps.  
L'humidité résiduelle peut se libérer.
- ▶ Essuyez l'eau de condensation de la cuve de la centrifugeuse. Utilisez pour cela un chiffon doux et absorbant.
- ▶ Éliminez les poussières collées aux fentes d'aération de la centrifugeuse à l'aide d'un pinceau ou d'une balayette au plus tard tous les 6 mois. Arrêtez la centrifugeuse et débranchez la fiche secteur.

## 7.5 Bris de verre

En cas d'utilisation de tubes en verre, des bris de verre peuvent apparaître dans la cuve de la centrifugeuse. Les éclats de verre en résultant sont projetés par les tourbillons d'air dans la cuve de la centrifugeuse lors de la centrifugation et rayent le rotor et les accessoires (effet de jet de sable). De toutes petites particules de verre s'accumulent dans les parties en caoutchouc (par ex. dans le manchon du rotor, le joint de la cuve de la centrifugeuse et les tapis en caoutchouc des adaptateurs).



### **AVIS ! Bris de verre dans la cuve de la centrifugeuse**

En cas de nombre de  $g$  trop élevé, il est possible que des tubes en verre se brisent à l'intérieur de la cuve de la centrifugeuse. Les bris de verre endommagent le rotor, ses accessoires et les échantillons.

- ▶ Observez les indications du fabricant des tubes sur les paramètres de centrifugation recommandés (chargement et vitesse de rotation).

### **Conséquences de la présence de bris de verre dans la cuve de la centrifugeuse :**

- Présence de poussière métallique noire dans la cuve de la centrifugeuse (lorsque la cuve du rotor est en métal).
- Rayures sur les surfaces de la cuve de la centrifugeuse et des accessoires.
- Réduction de la résistance aux produits chimiques de la cuve de la centrifugeuse.
- Contamination des échantillons.
- Usure des pièces en caoutchouc.

### **Comportement en cas de bris de verre**

1. Retirer les éclats et la poudre de verre de la cuve de la centrifugeuse et des accessoires.
2. Nettoyer avec soin le rotor et la cuve de la centrifugeuse. Nettoyer avec un soin particulier les alésages des rotors angulaires.
3. Changer si nécessaire les tapis en caoutchouc et les adaptateurs pour éviter tout dommage supplémentaire.
4. Vérifier régulièrement que les alésages du rotor ne présentent aucun dépôt et qu'ils sont en parfait état.

## 7.6 Décontamination avant l'expédition

Veillez tenir compte des informations suivantes si vous expédiez l'appareil pour réparation au service technique autorisé ou à votre distributeur agréé pour l'éliminer :



### **AVERTISSEMENT ! Dangers pour la santé à cause d'appareils contaminés.**

1. Observer les spécifications du certificat de décontamination. Vous le trouverez en tant que fichier PDF sur notre site Internet ([www.eppendorf.com/decontamination](http://www.eppendorf.com/decontamination)).
2. Décontaminer toutes les pièces que vous désirez expédier.
3. Remplir le certificat de décontamination et l'inclure dans votre envoi.

## 8 Résolution des problèmes

Si vous ne parvenez pas à résoudre l'erreur à l'aide des solutions proposées, contactez votre partenaire Eppendorf local. L'adresse se trouve sur Internet sous [www.eppendorf.com](http://www.eppendorf.com).

### 8.1 Remise à zéro du disjoncteur

Sur les appareils de 230 V et 120 V, les disjoncteurs thermiques se présentent sous forme de fusibles (sur tous les pôles). Dès que le disjoncteur est déclenché, elles mettent le contacteur à l'ARRÊT sans le remettre automatiquement en marche.

Pour réenclencher le contacteur du disjoncteur, procédez comme suit :

1. Arrêtez la centrifugeuse à l'aide de l'interrupteur général.
2. Attendez au moins 20 s, puis réenclenchez la centrifugeuse.

Le disjoncteur-contacteur est réactivé et la centrifugeuse est prête à la marche.

### 8.2 Pannes générales

Symptôme/message	Origine	Dépannage
Pas d'affichage.	Pas d'alimentation électrique.	▶ Contrôlez le branchement sur le secteur.
L'affichage indique <i>Interrupt</i> après mise sous tension de la centrifugeuse.	Panne de courant.	▶ Contrôlez le fusible secteur de l'appareil (voir <i>Remise à zéro du disjoncteur à la page 148</i> ). ▶ Contrôlez le fusible secteur du laboratoire. ▶ Appuyez sur la touche <b>OPEN</b> .
Il est impossible d'ouvrir le couvercle de l'appareil.	Le rotor tourne encore.	▶ Attendez que le rotor soit arrêté.
	Panne de courant.	1. Contrôlez le fusible secteur de l'appareil (voir <i>Remise à zéro du disjoncteur à la page 148</i> ). 2. Contrôlez le fusible secteur du laboratoire. 3. Actionnez le déverrouillage de secours du couvercle (voir p. 151).
<i>clean rotor</i>	200 cycles.	▶ Nettoyez le rotor et la cuve de la centrifugeuse (voir p. 143).
La centrifugeuse ralentit durant un cycle court de centrifugation bien que la touche <b>short</b> ait été pressée.	La touche <b>short</b> a été relâchée plus de deux fois (fonction de protection pour l'entraînement).	▶ Appuyez en continu sur la touche <b>short</b> pendant une centrifugation de courte durée.



### 8.3 Messages d'erreur

Procédez comme suit à l'apparition des messages d'erreur suivants :

1. Remédiez au problème (voir Remède).
2. Appuyez sur **OPEN** pour supprimer le message d'erreur.
3. Répétez la centrifugation si nécessaire.

Plusieurs raisons peuvent être à l'origine d'une seule erreur. L'origine réelle d'une erreur est signalée par un message sur l'affichage de l'appareil.

Symptôme/message	Origine	Dépannage
<i>no rotor</i> La centrifugeuse ne démarre pas.	Pas de rotor.	▶ Mettez le rotor en place.
<i>no rotor</i> La centrifugeuse ne démarre pas.	Erreur de l'entraînement ou d'identification du rotor.	▶ Éteignez la centrifugeuse et attendez >20 s.
<i>Press Open</i>	Impossible de verrouiller le couvercle.	1. Appuyez sur la touche <b>OPEN</b> . 2. Refermez le couvercle.
<i>Close lid</i>	Couvercle de la centrifugeuse mal fermé.	▶ Refermez le couvercle de la centrifugeuse avec force.
<i>Lift Lid</i> Le couvercle de la centrifugeuse ne s'ouvre pas.	Le couvercle de la centrifugeuse ne s'ouvre pas tout seul.	▶ Soulevez le couvercle de la centrifugeuse manuellement.
<i>IMBAL</i> La centrifugeuse a des soubresauts pendant l'accélération et s'arrête.	Le rotor est chargé de façon asymétrique.	▶ Chargez le rotor symétr.(voir p. 130)
<i>ROTOR</i> La centrifugeuse a des soubresauts pendant l'accélération et s'arrête.	Le rotor n'est pas assez vissé.	1. Fixez l'écrou du rotor correctement (voir p. 130). 2. Contrôlez la présence de fissures et de dommages sur le cône du rotor et l'arbre du moteur.
<i>ROTOR</i> La centrifugeuse a des soubresauts pendant l'accélération et s'arrête.	<ul style="list-style-type: none"> <li>• La centrifugeuse bascule.</li> <li>• Table non stable.</li> </ul>	▶ Posez la centrifugeuse sur une table fixe (voir p. 126).
<i>SPEED</i> La centrifugeuse s'arrête.	Vitesse de rotation de consigne du rotor trop élevée.	▶ Saisir une vitesse de rotation de consigne appropriée .

## Résolution des problèmes

Centrifuge 5804/5804 R/5810/5810 R

Français (FR)

Symptôme/message	Origine	Dépannage
<i>change rotor</i>	La durée d'utilisation maximum du rotor est atteinte. L'avertissement est affiché après 98 000, 99 000 et 99 600 fonctionnements, à raison de 3 fois après le cycle. Après 100 000 fonctionnements, il apparaît après chaque cycle.	▶ Veuillez contacter le service technique.
L'affichage de la température clignote. (uniquement 5804 R/5810 R)	Écart par rapport à la température définie : $\pm 3$ °C.	<ul style="list-style-type: none"> <li>▶ Contrôlez les réglages.</li> <li>▶ Attendez l'obtention de la température définie.</li> <li>▶ Contrôlez la bonne circulation d'air à travers la fente d'aération.</li> <li>▶ Faites fondre la glace ou désactivez l'appareil et laissez-le refroidir.</li> </ul>
<i>overtemp</i> (uniquement 5804 R/5810 R) La centrifugeuse s'arrête et émet un signal d'avertissement.	Écart de température par rapport à la valeur définie dans la cuve de rotor : $\pm 5$ °C.	<ul style="list-style-type: none"> <li>▶ Vérifiez les réglages.</li> <li>▶ Contrôlez la bonne circulation d'air à travers la fente d'aération.</li> <li>▶ Faites fondre la glace ou désactivez l'appareil et laissez-le refroidir.</li> </ul>
<i>Clear Memory</i>	Mémoire de programmation pleine.	▶ Supprimez quelques programmes .
<i>Interrupt</i>	Coupure secteur au cours d'un cycle.	▶ Contrôlez le branchement sur le secteur.
<i>Error 1</i>	Erreur au niveau du système de mesure des rotations.	▶ Si ce message d'erreur apparaît de nouveau, faites un essai avec un autre rotor.
<i>Error 2</i>	Détecteur de balourd en dérangement.	▶ Répéter le cycle.
<i>Error 3</i>	Erreur au niveau du système de mesure des rotations.	▶ Posez et vissez le rotor.
<i>Error 3</i>	Erreur au niveau du système de mesure des rotations.	▶ Laissez la centrifugeuse en marche pendant 12 min jusqu'à ce que la touche <b>OPEN</b> s'allume, puis ouvrez la centrifugeuse.
<i>Error 4</i>	Détecteur du système de verrouillage du couvercle déréglé.	▶ Éteignez la centrifugeuse et attendez >20 s.
<i>Error 5</i>	Ouverture du couvercle non autorisée ou interrupteur du couvercle défectueux durant un cycle.	<ol style="list-style-type: none"> <li>1. Attendez que le rotor soit arrêté.</li> <li>2. Ouvrez et refermez le couvercle de la centrifugeuse.</li> <li>3. Répéter le cycle.</li> </ol>
<i>Error 6 ou overload</i>	Tension du courant insuffisante.	▶ Contrôlez la tension secteur.
<i>Error 6 ou overload</i>	<ul style="list-style-type: none"> <li>• Convertisseur de fréquences surchargé.</li> <li>• Frein défectueux.</li> </ul>	▶ Arrêtez la centrifugeuse, laissez la refroidir pendant au moins 5 minutes puis rallumez-la.

Symptôme/message	Origine	Dépannage
<i>Error 8</i>	<ul style="list-style-type: none"><li>• Défaillance de l'entraînement.</li><li>• Rotor dévissé.</li><li>• Moteur défectueux.</li></ul>	<ol style="list-style-type: none"><li>1. Attendez que le rotor soit arrêté.</li><li>2. Vissez le rotor.</li><li>3. Répéter le cycle.</li></ol>
<i>Error 9 à Error 25</i>	Panne électronique.	▶ Éteignez la centrifugeuse et attendez >20 s.

## 8.4 Déverrouillage de secours

En cas de panne de courant, vous pouvez actionner manuellement le déverrouillage de secours si le couvercle de la centrifugeuse ne peut être ouvert.



### **AVERTISSEMENT ! Risque d'accident causé par un rotor en rotation.**

En cas de déverrouillage de secours du couvercle, il est possible que le rotor continue à tourner pendant encore quelques minutes.

- ▶ Attendez que le rotor soit arrêté pour actionner le déverrouillage de secours.
- ▶ Vérifiez en regardant à travers le verre-regard du couvercle de la centrifugeuse.

Vous avez besoin de la clé du rotor standard, qui est jointe à la centrifugeuse.

1. Débranchez la fiche secteur.
2. Ôtez le capuchon en plastique du déverrouillage d'urgence. Il se trouve au milieu, sur la partie avant de l'appareil.
3. Glissez la clé du rotor dans l'ouverture hexagonale qui se trouve derrière, jusqu'à ce que vous sentiez une résistance.
4. Tournez la clé du rotor dans le sens inverse des aiguilles d'une montre en forçant.  
Le couvercle de la centrifugeuse est déverrouillé.
5. Ouvrez le couvercle de la centrifugeuse.
6. Ôtez la clé du rotor et remettez les capuchons en plastique en place.

## 9 Transport, stockage et mise au rebut

### 9.1 Transport



**ATTENTION ! Risque de blessures par suite de soulever et porter des charges lourdes**

L'appareil est lourd. Soulever et porter l'appareil peut entraîner des maux de dos.

- ▶ Pour transporter et soulever l'appareil, garantir un nombre suffisant d'assistants.
- ▶ Pour le transport, utiliser un support de transport.

- ▶ Avant le transport de la centrifugeuse, retirer le rotor.
- ▶ Utiliser l'emballage d'origine pour le transport.

	Température de l'air	Humidité relative de l'air	Pression atmosphérique
Transport général	-25 °C – 60 °C	10 % – 75 %	30 kPa – 106 kPa
Fret aérien	-20 °C – 55 °C	10 % – 75 %	30 kPa – 106 kPa

### 9.2 Stockage

	Température de l'air	Humidité relative de l'air	Pression atmosphérique
dans l'emballage de transport	-25 °C – 55 °C	10 % – 75 %	70 kPa – 106 kPa
sans emballage de transport	-5 °C – 45 °C	10 % – 75 %	70 kPa – 106 kPa

### 9.3 Mise au rebut

Si le produit doit être éliminé, observer les règles applicables dans l'Union Européenne.

#### Informations sur la mise au rebut des appareils électriques et électroniques :

Au sein de l'Union Européenne, l'élimination des appareils électriques est régie par les lois nationales basées sur la Directive Européenne 2012/19/EU relatives aux déchets d'équipements électriques et électroniques (WEEE).

Selon ces règles, certains appareils vendus après le 13 août 2005 en B2B seulement ne peuvent plus être éliminés avec les ordures ménagères ni ramassés avec les encombrants. Cela est indiqué par l'identifiant suivant :



Comme les règles de mise au rebut peuvent différer d'un pays à l'autre dans l'UE, veuillez contacter le cas échéant votre fournisseur.

DOMINIQUE DUTSCHER SAS

Annex

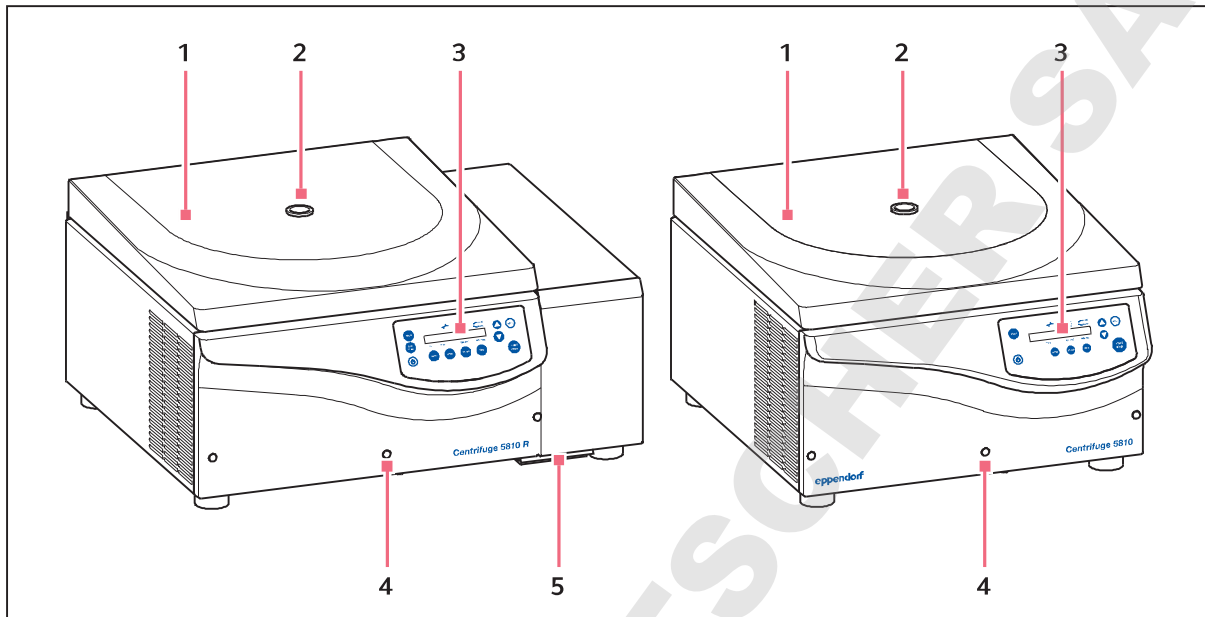

Fig. 0-1: Centrifuge 5810 R and 5810. The Centrifuges 5804 R and 5804 are similar in design.

- |                                     |  |
|-------------------------------------|--|
| <b>1 Centrifuge lid</b>             | <b>4 Emergency release</b>                                       |
| <b>2 Monitoring glass</b>           | <b>5 Condensation water tray (Centrifuge 5804 R/5810 R only)</b> |
| <b>3 Control panel with display</b> |  |

Task/function	Keys	Display
Set parameter	1. Press  or  etc. 2. Press  or .	1. Selected parameter flashes. 2. New value appears.
Soft start/stop	1. Press  repeatedly. 2. Press  or  to select ramp.	: Acceleration ramp 0 (long) ... 9 (short). : Deceleration ramp 0 (long) ... 9 (short).
Alarm on/Alarm off	▶ Press  +  simultaneously.	<i>Alarm on/Alarm off</i>
Programming (during rotor stop only)	1. Set parameter. 2. Press 2 x . 3. Store: Press  > 2 s.	1. Parameters 2. P...: first idle program no. 3. OK
At set rpm (with open centrifuge lid only)	Press  > 4 s.	: on : off

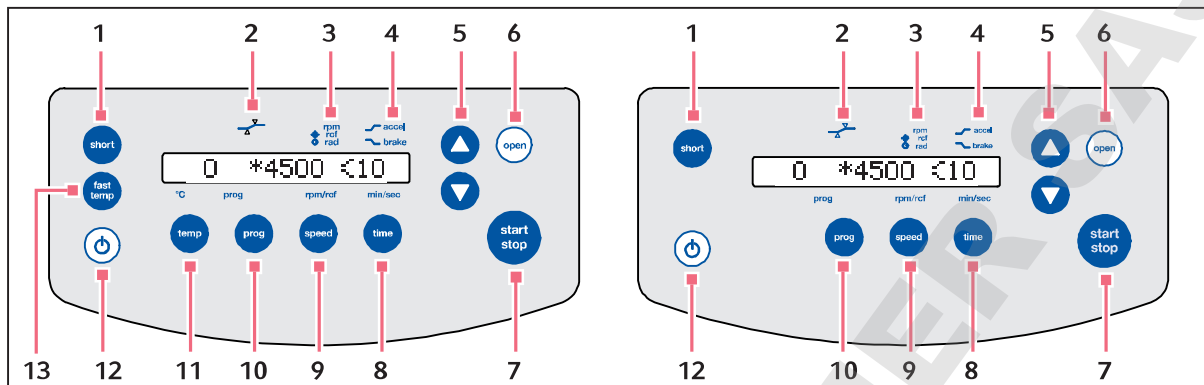

Fig. 0-2: Control panel of the Centrifuge 5804 R/5810 R and the Centrifuge 5804/5810.

- |  |  |
|--|--|
| <p><b>1 short key</b><br/>Short spin centrifugation</p> <p><b>2 At set rpm function status</b></p> <p><b>3 speed (rpm), <i>g</i>-force (rcf) *, and radius setting</b><br/>⊙ indicator</p> <p><b>4 Symbol for acceleration ↗ and braking ↘</b></p> <p><b>5 Arrow keys</b><br/>Set parameter values</p> <p><b>6 open key</b><br/>Release centrifuge lid</p> <p><b>7 start/stop key</b><br/>Start or stop centrifugation</p> | <p><b>8 time key</b><br/>Select run time setting</p> <p><b>9 speed key</b><br/>Select speed setting</p> <p><b>10 prog key</b><br/>Select or save program</p> <p><b>11 temp key</b><br/><b>Centrifuge 5804 R/5810 R only:</b> Select temperature setting</p> <p><b>12 Standby Ⓞ key</b></p> <p><b>13 fast temp key</b><br/><b>Centrifuge 5804 R/5810 R only:</b> Start FastTemp temperature control run</p> |
|--|--|

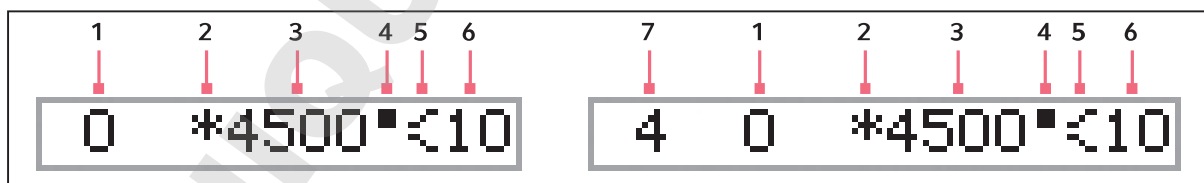

Fig. 0-3: Display of the Centrifuge 5804 R/5810 R and the Centrifuge 5804/5810

- |   |  |
|---|--|
| <p><b>1 Temperature (only 5804 R/5810 R)</b></p> <p><b>2 Program number</b></p> <p><b>3 Symbol for <i>g</i>-force (rcf)</b></p> <p><b>4 <i>g</i>-force (rcf)/rotational speed (rpm)</b></p> | <p><b>5 Symbol flashes when rotor is in motion</b></p> <p><b>6 Symbol for acceleration ↗ and braking ↘</b></p> <p><b>7 Centrifugation time</b></p> |
|---|--|



**Rotor code:**

All Eppendorf® rotors are identified using a simple, alphanumeric format that represents the technical specifications in a uniform series of letters and numbers.

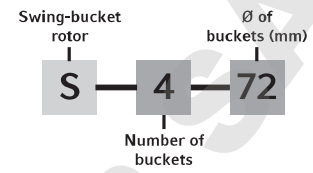
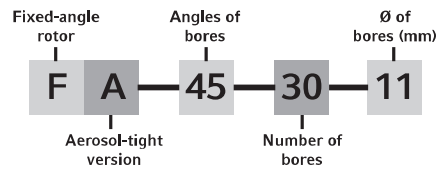

**Rotor code:**

All Eppendorf® rotors are identified using a simple, alphanumeric format that represents the technical specifications in a uniform series of letters and numbers.

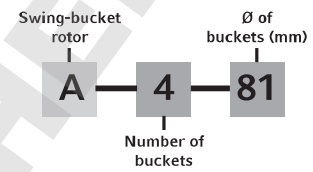
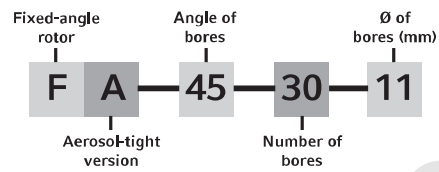

DOMINIQUE DUTSCHER

# Declaration of Conformity

The product named below fulfills the requirements of directives and standards listed. In the case of unauthorized modifications to the product or an unintended use this declaration becomes invalid.

**Product name:**

Centrifuge 5804 / 5804 R , 5810 / 5810 R  
including accessories

**Product type:**

Laboratory Centrifuges

**Relevant directives / standards:**

2006/95/EG: EN 61010-1, EN 61010-2-20  
2004/108/EG: EN 61000-6-1, EN 61000-3-2, EN 61000-3-3, EN 61326-1  
98/79/EG: EN 14971, EN 61010-2-101, EN 61326-2-6, EN 62366, EN 18113-3  
2011/65/EU



Management Board



Portfolio Management

Date: November, 26, 2013

Your local distributor: [www.eppendorf.com/contact](http://www.eppendorf.com/contact)  
Eppendorf AG · 22331 Hamburg · Germany  
[eppendorf@eppendorf.com](mailto:eppendorf@eppendorf.com)

ISO 9001  
Certified

ISO 13485  
Certified

ISO 14001  
Certified

Eppendorf and the Eppendorf Logo are registered trademarks of Eppendorf AG Hamburg/Germany. All rights reserved incl. graphics and pictures. Copyright 2013 © by Eppendorf AG.

# Certificate of Compliance

Certificate Number 20111226-E215059  
Report Reference E215059- E215059-A3-UL  
Issue Date 2011-DECEMBER-26

Page 1 of 1



*Issued to:* EPPENDORF A G  
BARKHAUSENWEG 1  
22339 HAMBURG GERMANY

*This is to certify that representative samples of* **LABORATORY USE ELECTRICAL EQUIPMENT**  
Models 5804, 5805T, 5805F, 5810, 5811T, 5811F

*Have been investigated by Underwriters Laboratories in accordance with the Standard(s) indicated on this Certificate.*

*Standard(s) for Safety:* UL 61010-1, (Electrical Equipment for Measurement, Control, and Laboratory Use; Part 1: General Requirements)  
CAN/CSA-C22.2 No. 61010-1, (Electrical Equipment for Measurement, Control, and Laboratory Use; Part 1: General Requirements)  
IEC 61010-2-020-Safety Requirements for Electrical Equipment for Measurement, Control, and Laboratory use.

*Additional Information:* See UL On-line Certification Directory at [WWW.UL.COM](http://WWW.UL.COM) for additional information.

This is to certify that representative samples of the product as specified on this certificate were tested according to the current UL requirements.

**Only those products bearing the UL Listing Mark for the US and Canada should be considered as being covered by UL's Listing and Follow-Up Service meeting the appropriate requirements for US and Canada.**

The UL Listing Mark for the US and Canada generally includes: the UL in a circle symbol with "C" and "US" identifiers;  the word "LISTED"; a control number (may be alphanumeric) assigned by UL; and the product category name (product identifier) as indicated in the appropriate UL Directory.

**Look for the UL Listing Mark on the product**

**William R. Carney**  
**Director, North American Certification Programs**

Underwriters Laboratories Inc.

Any information and documentation involving UL Mark services are provided on behalf of Underwriters Laboratories Inc. (UL) or any authorized licensee of UL.

For questions, please contact a local UL Customer Service Representative at <http://www.ul.com/global/eng/pages/corporate/contactus>



## Certificate of Containment Testing

### Containment Testing of Swing Out Rotor with Buckets [A-2-DWP-AT (5820 710.004-00)] and Autoclaved (x50) lids in the Eppendorf Centrifuge 5810

**Report No. 104-09 B**

**Report prepared for:** Eppendorf AG, Hamburg, Germany  
**Issue Date:** 31<sup>st</sup> March 2010 (amended 17<sup>th</sup> Aug 10)

#### Test Summary

Swing out rotor with buckets [A-2-DWP-AT (5820 710.004-00)] and autoclaved (x50) lids was containment tested in the Eppendorf 5810 centrifuge, in accordance with Annex AA of IEC 1010-2-20. The sealed bucket was shown to contain the spill of micro-organisms and therefore prevent any release.

**Report Written By**

A handwritten signature in blue ink, appearing to be "Alloc", written over a horizontal dashed line.

**Report Authorised By**

A handwritten signature in blue ink, written over a horizontal dashed line.



Health Protection Agency  
Microbiological Services  
Porton Down  
Salisbury  
Wiltshire SP4 0JG  
United Kingdom



## Certificate of Containment Testing

### **Containment Testing of Rotor A-4-44 and Sealed Buckets and Lids (Cap 100, Order no. 5804 712.005) in the Eppendorf Centrifuge 5810**

**Report No. 352-97 (Part 1)**

**Report prepared for:** Eppendorf AG, Hamburg, Germany

**Issue Date:** Original report issued 8<sup>th</sup> September 1997

Certificate issued 18<sup>th</sup> October 2010

#### **Test Summary**

Rotor A-4-44 and sealed buckets and lids (Cap 100, Order no. 5804 712.005) were containment tested in the Eppendorf Centrifuge 5810, using Annex AA of IEC 1010-2-020. The sealed buckets were shown to contain the spill within the centrifuge.

**Report Written By**

*Anna May*  
-----

**Report Authorised By**

*[Signature]*  
-----

Health Protection Agency  
Microbiological Services  
Porton Down  
Salisbury  
Wiltshire SP4 0JG  
United Kingdom



## Certificate of Containment Testing

# Containment Testing of Rotor A-4-62 and Sealed Buckets and Lids (Cap 250/1, Order no. 5810 710.006) in the Eppendorf Centrifuge 5810

**Report No. 352-97 (Part 2)**

**Report prepared for:** Eppendorf AG, Hamburg, Germany  
**Issue Date:** Original report issued 8<sup>th</sup> September 1997  
Certificate issued 18<sup>th</sup> October 2010

### Test Summary

Rotor A-4-62 and sealed buckets and lids (Cap 250/1, Order no. 5810 710.006) were containment tested in the Eppendorf Centrifuge 5810, using Annex AA of IEC 1010-2-020. The sealed buckets were shown to contain the spill within the centrifuge.

**Report Written By**

*Anna May*  
-----

**Report Authorised By**

*[Signature]*  
-----

Centre of Emergency Preparedness and Response  
Health Protection Agency  
Porton Down  
Salisbury  
Wiltshire SP4 0JG  
United Kingdom



## Certificate of Containment Testing

400ml Rectangular Buckets fitted with  
Sealed Caps in Eppendorf Centrifuge 5810  
containing Rotor A-4-81

**Report No. 1000-06**

**Report prepared for:** Eppendorf AG, Hamburg, Germany  
**Issue Date:** 21<sup>st</sup> March 2006

### Test Summary

400 ml rectangular buckets fitted with sealed caps were  
containment tested in the Eppendorf centrifuge 5810  
containing rotor A-4-81, using Annex AA of IEC 1010-2-20.  
The buckets were shown to contain a large spill.

**Report Written By**

A blue ink signature written over a horizontal dashed line.

**Report Authorised By**

A blue ink signature written over a horizontal dashed line.





## Certificate of Containment Testing

# Containment Testing of Rotor FA-45-6-30 [(5820 715.103-00) and autoclaved lid (x50)] in the Eppendorf Centrifuge 5810R

**Report No. 40-10B**

**Report prepared for:** Eppendorf AG, Hamburg, Germany  
**Issue Date:** 19<sup>th</sup> July 2010 (amended 17<sup>th</sup> Aug 10)

### Test Summary

Rotor FA-45-6-30 (5820 715.103-00) and autoclaved lid (x50) was containment tested in the Eppendorf centrifuge 5810R, in accordance with Annex AA of IEC 1010-2-20. The sealed rotor was shown to contain the spill of micro-organisms and therefore prevent any release.

**Report Written By**

A blue ink signature written over a horizontal dashed line.

**Report Authorised By**

A blue ink signature written over a horizontal dashed line.





# Certificate of Containment Testing

## Containment Testing of Rotor FA-45-20-17 (5820 765.100-00) in the Eppendorf 5810/R Bench Top Centrifuge

Report No. 35/13

**Report Prepared For:** Eppendorf AG, Hamburg, Germany

**Issue Date:** 24<sup>th</sup> April 2013

### Test Summary

Rotor FA-45-20-17 (5820 765.100-00) was containment tested in the Eppendorf 5810/R bench top centrifuge, using Annex AA of IEC 61010-2-020:2006 (2<sup>nd</sup> Ed.). The sealed rotor was shown to contain a spill within the centrifuge.

**Report Written By**

**Name:** Miss Anna Moy

**Title:** Biosafety Scientist

**Report Authorised By**

**Name:** Mrs Sara Speight

**Title:** Senior Biosafety Scientist



# Certificate of Containment Testing

## Containment Testing of Rotor FA-45-48-11(5820 760.109-00) in the Eppendorf 5810/R Bench Top Centrifuge

**Report No. 199-12**

**Report Prepared For:** Eppendorf AG, Hamburg, Germany

**Issue Date:** 12<sup>th</sup> September 2012

### Test Summary

Rotor FA-45-48-11 (5820 760.109-00) was containment tested in the Eppendorf 5810/R bench top centrifuge, using Annex AA of IEC 1010-2-20. The sealed rotor was shown to contain a spill within the centrifuge

**Report Written By**

Handwritten signature of Anna Moy in blue ink.

**Name: Miss Anna Moy**

**Title: Biosafety Scientist**

**Report Authorised By**

Handwritten signature of Sara Speight in blue ink.

**Name: Mrs Sara Speight**

**Title: Senior Biosafety Scientist**





# Certificate of Containment Testing

## Containment Testing of Rotor S-4-104 with Round Buckets (5820 741.007-00) in the Eppendorf 5810/R Bench Top Centrifuge

**Report No. 196-12 A**

**Report Prepared For:** Eppendorf AG, Hamburg, Germany

**Issue Date:** 12<sup>th</sup> September 2012

### Test Summary

Rotor S-4-104 with Round Buckets (5820 741.007-00) was containment tested in the Eppendorf 5810/R bench top centrifuge, using Annex AA of IEC 1010-2-20. The sealed rotor was shown to contain a spill within the centrifuge

**Report Written By**

Handwritten signature of Anna Moy in blue ink.

**Name:** Miss Anna Moy  
**Title:** Biosafety Scientist

**Report Authorised By**

Handwritten signature of Mrs Sara Speight in blue ink.

**Name:** Mrs Sara Speight  
**Title:** Senior Biosafety Scientist



# Certificate of Containment Testing

## Containment Testing of Caps for Rotor S-4-104 with DWP- Buckets in the Eppendorf 5810/R Bench Top Centrifuge

Report No. 111/13 A

**Report Prepared For:** Eppendorf AG, Hamburg, Germany  
**Issue Date:** 10<sup>th</sup> April 2014

### Test Summary

Caps for rotor S-4-104 with DWP-Buckets were containment tested in the Eppendorf 5810/R bench top centrifuge, using Annex AA of IEC 61010-2-020:2006 (2<sup>nd</sup> Ed.). The sealed rotor was shown to contain a spill within the centrifuge.

**Report Written By**

**Name:** Miss Anna Moy  
**Title:** Biosafety Scientist

**Report Authorised By**

**Name:** Mrs Sara Speight  
**Title:** Senior Biosafety Scientist

**DOMINIQUE DUTSCHER SAS**

# Evaluate Your Manual

Give us your feedback.  
[www.eppendorf.com/manualfeedback](http://www.eppendorf.com/manualfeedback)



Eppendorf AG  
22331 Hamburg  
Germany

Your local distributor: [www.eppendorf.com/contact](http://www.eppendorf.com/contact)  
[eppendorf@eppendorf.com](mailto:eppendorf@eppendorf.com) · [www.eppendorf.com](http://www.eppendorf.com)

DOMINIQUE DUTSCHER SAS