



Tel : 01 60 26 91 91  
 Fax : 01 60 26 84 62  
 Email : [info@e3cortex.fr](mailto:info@e3cortex.fr)  
 Site : [www.e3cortex.fr](http://www.e3cortex.fr)

## TECHNICAL DATA SHEET

Ref: 3BIO000919

Indice : 5

# BIOTAINER 1.8L APPROVED 4GU

### PRODUCT PROPERTIES

### OVERVIEW

#### Use :

The BIOTAINER 1.8L is a packaging module for transfer of infectious substances (class 6.2) at ambient temperature (or at controlled temperature with an OVERPACK - Consult us).

#### Approvals :

The BIOTAINER 1.8L packaging is UN approved (IATA, IMDG, RID, ADR).  
 The certificate of approval is available upon request.

#### Composition :

- A cardboard envelope, with an automatic bottom
- A leak proof secondary container that comply with the 95kPa differential pressure tests, and intended to receive the primary container(s).
- Screw cap closure, fitted with a joint and with a ring inviolability.
- Inside the container are: 1 absorbent sheet and 2 bands of wedging material (*Bull pack*).

#### Quality of materials:

- Envelope: Microflute cardboard
- Container/cap Autoclavable PP plastic (121°C / 30 min).
- Joint: Silicone (Non autoclavable).

#### Characteristics :

Reference	3BIO000919		
Outside dimensions.	150 x 165 x 205 mm		
Inside dimensions	140 x 140 x 195 mm		
Container dimensions	Ø125 x Height 145 mm		
Pure weight	0,51 Kg		
Authorized maximum weight	0,7 Kg		
Quantity of units per box	24		
Dimensions of the box	620 x 500 x 440 mm		
Transport	Courier	Chartering	
Quantity per pallet		20 boxes (480 units Bio 1,8L)	16 boxes (384 units Bio 1,8L)
Dimensions and maximum height of the pallet	8 boxes (192 units Bio 1,8L) 120x80 cm & H : 190 cm +/- 120 Kg	125x100 cm & H : 235 cm	125x100 cm & H : 190 cm
Maximum weight of the pallet (125x100 cm)		+/- 300 Kg	+/- 240 Kg



#### Properties:

The BIOTAINER 1.8L allows the transfer of infectious products at ambient temperature. Its conception makes it a small and resistant packaging in once, allowing a very quick and easy implementation. The BIOTAINER 1.8L can be combined with an insulated box (OVERPACK) for the shipping at controlled temperature.

#### Options:

The BIOTAINER 1.8L model can be customized according to customer's request (color marking, coloured cardboard, logos), according to quantity.

The BIOTAINER 1.8L underwent successfully the qualification tests required by the regulation. A detailed operation manual allows the implementation without risk of error. It must be used only with all of its constituent elements to comply with its certification.

Writer : W Richard

Date : 25/02/2008

Visa : WR

Modified by : H.Duquesne

Date : 27/11/2020

Visa : HD

Approving : B.Devos

Date : 02/12/2020

Visa : BD

EQR04 /Fichtech 01D



Tel : 01 60 26 91 91  
 Fax : 01 60 26 84 62  
 Email : [info@e3cortex.fr](mailto:info@e3cortex.fr)  
 Site : [www.e3cortex.fr](http://www.e3cortex.fr)

## TECHNICAL DATA SHEET

Ref: 3BIO000919

Indice : 5

### BIOTAINER 1.8L APPROVED 4GU

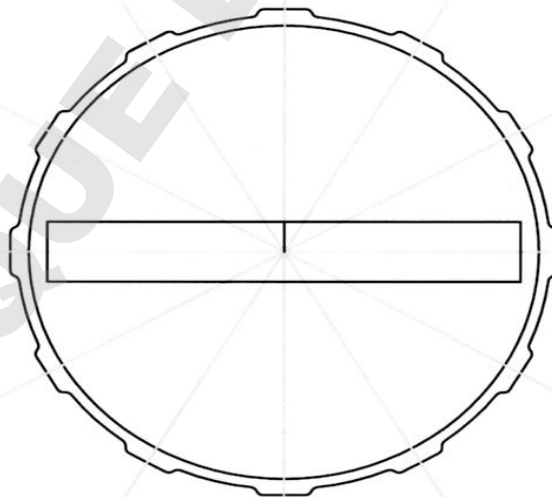
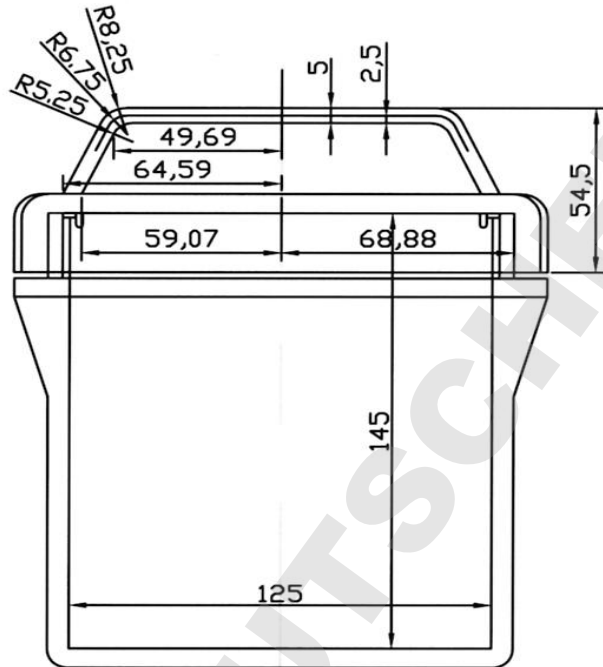

Dessiner par :	Vérifier par : SAMY_JEROME	Approuver par : - date : SAMY JEROME le 19/09/2003	Date : 19/09/2003	Echelle : 1/1
			BIOTAINER_1.8L	
			RECIPIENT_SECONDAIRE	

Writer : W.Richard	Date : 25/02/2008	Visa : WR	EQR04 /Fichtech 01D
Modified by : H.Duquesne	Date : 27/11/2020	Visa : HD	
Approving : B.Devos	Date : 02/12/2020	Visa : BD	