



LTF 425

THIS CHEST FREEZER STORES YOUR SAMPLES UNDER OPTIMAL CONDITIONS. The single compressor technology provides reliable low temperature freezing and high temperature uniformity.



SINGLE
COMPRESSOR
SYSTEM



FILTERLESS
CONSTRUCTION

COOLING SYSTEM

Arctiko's LTF range utilizes our single compressor technology. This means fewer mechanical components taking up space and lowering unnecessary heat-and noise dissipation. The technology ensures the best possible storage capacity per square meter of any chest freezer models in the market.

With Arctiko, you are maximizing the amount of samples you can store, while retaining the best possible cooling performance.

OPTIMIZED STORAGE CAPACITY

The freezer has optimized internal storage for the best overlook. With the standard included stackable basket and the optional stainless steel front rack storage system the samples will be easy accessible at any time.

The freezer also has a premade access port with no extra cost involved, making it easier to monitor or inspect the unit with external probes.

FILTERLESS CONSTRUCTION

Our filterless construction makes cleaning unnecessary. The evaporator coils are spaced so far apart that dust will not be trapped and obstruct the airflow.

The filterless construction eliminates the need for filters entirely, saving you maintenance time and cost.

MAIN DIMENSION FOR LTF 425

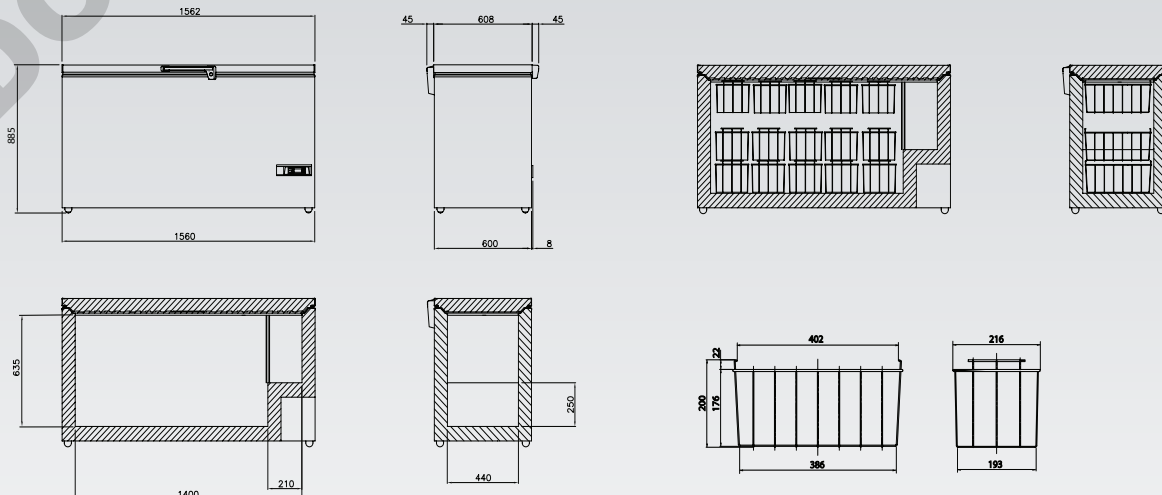



Lock on handle for optimal security of the valued samples.
Comes as a standard feature.



Optimal storage capacity and overview of the stored samples with the baskets.

OPTIONAL ACCESSORIES

- Temperature chart recorder
- Rollers on metal frame
- GSM alarm module
- Voltage converter
- Voltage stabilizer
- Racks & boxes
- Jumbo basket
- Basket

MAIN SPECIFICATIONS

Item code	DAI 0116
Temperature range (°C)	-30 / -60
Max. ambient temperature (°C)	25
Capacity (L)	368
Exterior dimensions WxDxH (mm)	1562x698x890
Interior dimensions WxDxH (mm)	1400x440x635
Weight (KG)	88
Insulation (mm)	80
Cooling technology	static
Controller model / probe type	Dixell / PT1000

POWER

Power supply (V)	230
Frequency (Hz)	50
Power consumption (kWh/24H)	8,3
AMP (A)	2,8
Power (Watt)	434
Horse power (HP)	3/4

ALARM FUNCTIONS

Alarm display as text - not codes	no
Visual / acoustic alarm	yes / yes
Power failure alarm	no
Adjustable high / low temperature alarm	yes / yes
Open door alarm	no
Probe failure alarm	yes
Low battery alarm	no
Compressor failure alarm	no
Battery backup for alarms (approx. hrs.)	no

DATA LOGGING & EXTERNAL CONNECTION

Voltage free contact for remote alarm (e.g. GSM module)	yes
Electronic data logger	no
RS 485 port	no
USB port for software update & data download	no
Temperature chart recorder	optional

DISPLAY FEATURES

Display type	LED display
Number of optional reference probes	no
Password protection for turning unit on / off	no
Temperature graph on display	no

OTHER FEATURES

Automatic defrost	no
Antifreeze function	no
Vacuum release port	no
Access port for external probe etc. (int. diameter mm)	12
Light	no
Lock with key	yes
Castors (total pcs) / castors with brake (pcs)	4 / optional
Fixed feet (pcs) / levelling feet (pcs)	no
Baskets (pcs)	4
Max. no. of baskets (pcs)	15
Max. load per basket (kg)	14,5
Total capacity of 50 mm boxes 9x9 dividers (pcs)	282
Total capacity of 75 mm boxes 9x9 dividers (pcs)	204
Total capacity of 96 mm boxes 9x9 dividers (pcs)	129

REFRIGERATION & CABINET

Number of compressors	1
Refrigerant	HC
Interior cabinet material	prepainted steel
Exterior cabinet material	prepainted steel
Colour (exterior cabinet)	white
Foam type	polyurethane
VIP vacuum insulated panels	no

SHIPPING

Shipping weight (KG)	132
Shipping dimensions WxDxH (cm)	166x76x106
Shipping volume (m ³)	1,34