

# ***Instruction Manual***

---

Rocker 300 / 300DC / 400 / 410

Rocker 800 / 801 / 810 / 811

Oil Free Vacuum Pump

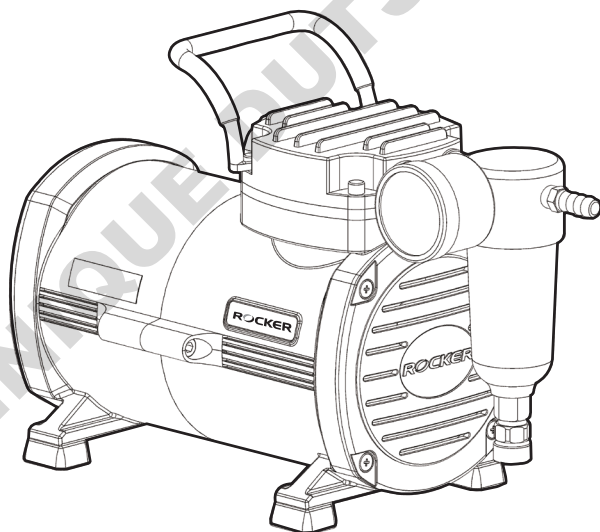

## **ROCKER**

Please read this instruction manual before using this product.

## Important Notice

This instrument is designed for laboratory usage only. Please read this manual carefully before installing or operating this equipment. The instrument shall not be modified in any way. Any modification will void the warranty and may result in potential hazard. We are not responsible for any injury or damage caused by any non-intended purposes and modifying the instrument without authorization.

1. Check the voltage specified on the name-plate and ensure it matches the line voltage in your location.
2. Install the instrument in a clean, dust-less and ventilated area under 40°C.
3. Never use the pump with any corrosive, chemical or flammable gas.
4. The Prote™ filter cartridge can prevent a large amount of liquid from overflowing into the pump. Please ensure the liquid level of flask not exceed safety level.
5. To ensure proper function of the Prote™ protection device, the pump must be resting on a flat level surface during use and should not be moved when running. If the buoy closes during pump operation, it must be manually reset by uninstalling and reinstalling the filter cartridge.
6. The filter cartridge is used to absorb moisture and dust. Please replace the cartridge to maintain pumping efficiency when it becomes dirty or color-changing.
7. The pump is not designed to start against applied vacuum. To prevent damage, verify that the pump inlet is at atmospheric pressure before each start. If necessary, the inlet can be vented to atmosphere by partially unscrewing the vacuum regulator knob.
8. This pump has a thermal protection device that automatically shuts-off when it becomes overheated.
9. The temperature of the surface of pump is very high after use or during work, please don't touch it to avoid being burnt.
10. Do not use any lubricant, which may damage the pump.
11. If the supply cord is damaged, Please contact the manufacturer or your service local dealer for replacement to avoid hazard.

## Unpacking

When unpacking, notice if the pump is in good condition. If not, please contact the distributor or contact us by e-mail: [export@rocker.com.tw](mailto:export@rocker.com.tw) immediately for assistance.

## Rocker 300 Main Part Diagram



Position	Designation
1	On/Off Switch
2	Muffler (Air Outlet)
3	Air Inlet
4	Vacuum Gauge
5	Prote™ Filter Cartridge
6	Moisture Trap
7	Drain Valve (Regulator)

## Rocker 300DC Main Part Diagram



Position	Designation
1	On/Off Switch
2	Muffler (Air Outlet)
3	Air Inlet
4	Vacuum Gauge
5	Prote™ Filter Cartridge
6	Moisture Trap
7	Drain Valve (Regulator)
8	Power Cord

## Rocker 400 / 410 Main Part Diagram



Position	Designation
1	On/Off Switch
2	Muffler (Air Outlet)
3	Air Inlet
4	Vacuum Gauge
5	Prote™ Filter Cartridge
6	Moisture Trap
7	Drain Valve (Regulator)

## Rocker 800 Main Part Diagram



Position	Designation
1	Muffler (Air Outlet)
2	Vacuum Gauge
3	Vacuum Regulator
4	Air Inlet
5	On/Off Switch

## Rocker 801 Main Part Diagram



Position	Designation
1	On/Off Switch
2	Muffler (Air Outlet)
3	Air Inlet
4	Vacuum Gauge
5	Filter Cartridge
6	Moisture Trap
7	Vacuum Regulator

## Rocker 810 Main Part Diagram



Position	Designation
1	Muffler (Air Outlet)
2	Vacuum Gauge
3	Vacuum Regulator
4	Air Inlet
5	On/Off Switch



## Rocker 811 Main Part Diagram



Position	Designation
1	On/Off Switch
2	Muffler (Air Outlet)
3	Air Inlet
4	Vacuum Gauge
5	Filter Cartridge
6	Moisture Trap
7	Vacuum Regulator

## Operation

### Operating procedure

1. Press on/off ① switch to activate the pump after making sure all tubing are well connected.
2. To setup vacuum by adjusting the regulator ③ or ⑦.

*\* Warning: When pump is used for aqueous solution filtration, please ensure the liquid level of flask not exceed safety level. Failure to comply could result in serious damage to the pump and void the warranty. If it occurs, please contact the distributor immediately for service.*

## Maintenance

1. After finishing the experiment, please remove the liquid in the moisture trap and pumping the air for at least 2 minutes to withdraw the residual steam.

### How to reset the Prote™ protection device

1. Remove the moisture trap ⑥ and filter cartridge ⑤ by rotating clockwise.
2. Disassemble the filter cartridge ⑤ to ensure the buoy is not closed.
3. Reinstall all components, filter cartridge and moisture trap back.

### How to replace cartridge

1. Please replace the cartridge when it becomes dirty or color-changing.
2. Please remove the moisture trap ⑥ by rotating it clockwise.
3. Replace the cartridge by the same way.

## Ordering Information

167300-11(22)	Rocker 300 Vacuum pump, AC110V,60Hz (AC220V,50Hz)
167330-00	Rocker 300DC Vacuum pump, DC12V
167400-11(22)	Rocker 400 Vacuum pump, AC110V,60Hz (AC220V,50Hz)
167410-11(22)	Rocker 410 Vacuum pump, AC110V,60Hz (AC220V,50Hz)
167800-11(22)	Rocker 800 Vacuum pump, AC110V,60Hz (AC220V,50Hz)
167801-11(22)	Rocker 801 Vacuum pump, AC110V,60Hz (AC220V,50Hz)
167810-11(22)	Rocker 810 Vacuum pump, AC110V,60Hz (AC220V,50Hz)
167811-11(22)	Rocker 811 Vacuum pump, AC110V,60Hz (AC220V,50Hz)
167301-06	Moisture trap / Vacuum regulator for Rocker 300/400/410
167301-07	Prote™ filter cartridge for Rocker 300/400/410
167300-42	Muffler (Air outlet) for Rocker 300/400/410
167801-06	Moisture trap / Vacuum regulator for Rocker 801/811
167801-07	Filter cartridge for Rocker 801/811 (without Prote™ overflow protection)
167600-42	Muffler (Air outlet) for Rocker 800/801/810/811
167300-62	Rocker 300 Repair kit
167400-62	Rocker 400 Repair kit
167410-62	Rocker 410 Repair kit
167800-62	Rocker 800 Repair kit
167801-62	Rocker 801 Repair kit
167810-62	Rocker 810 Repair kit
167811-62	Rocker 811 Repair kit

DOMINIQUE DUTSCHER SAS

**Rocker Scientific Co., Ltd.**

Tel: +886-2-26033311 Fax: +886-2-26036622

E-mail: [export@rocker.com.tw](mailto:export@rocker.com.tw) <https://www.rocker.com.tw>