

---

**Note:** Bioer Co. reserves the right to modify this manual at any time without notice.

---

Patent materials are included in this manual. All rights reserved. No part of this manual shall be photocopied, reproduced, or translated into other languages without written permission from Bioer Co.

**Please read this manual carefully before the Mixing Block is first operated!**

**File No.: BYQ6008000000E/USM**

**File Version: October, 2008    Version 1.9**

## Important Note

### 1 CONVENTION

---

**Note:** Please pay close attention to the important information in this column. Failure to follow the advice in this column will possibly result in damage to or the malfunctioning of Mixing Block.

---

---

**Warning!** This symbol reminds user should be cautious when performing this operation/procedure. Failure to follow the requirements in this column could possibly result in personal injury.

---

### 2 SAFETY

During the operation, maintenance, or repair of Mixing Block, the following safety measures should be taken. Otherwise, the safeguards provided by the Mixing Block are likely to be damaged, the rated safety level to be reduced, and the rated operation conditions to be affected.

*Bioer Co. shall not be in any way responsible for the consequences resulting from operator's not observing the following requirements.*

---

**Note:** This instrument is intended for indoor use only.

---

#### a) Grounding

A.C. power's grounding should be reliable to safeguard against an electric shock. The 3-pin plug supplied with the Mixing Block's power cable is a safety device that should be matched with a suitable grounded socket. Never allow the third ground pin to be floating. If the 3-pin plug cannot be inserted, it is recommended to ask an electrician to install an appropriate power socket

#### b) Keep Away from Electric Circuits

The operator is forbidden to open the Mixing Block randomly. Changing components or adjusting certain parameters inside the device must be accomplished by the certificated professional maintenance personnel only. Do not change elements while the power is still on.

#### c) A.C. Power Considerations

Before turning on the power, always make sure that the mains voltage is within the range of required power supply ( $\pm 10\%$  difference is allowed) and the rating current of the power socket meets the required specification as shown in below contents.

#### d) A.C. Power Line Considerations

As an accessory of the Mixing Block, the A.C. power supply should be the default device. Once it is damaged, the A.C. power line may not be repaired, but must be replaced by a new one. The power supply should be free of heavy objects during Mixing Block's operation. Keep the power supply away from areas where people gather regularly.

#### e) Connect the A.C. Power Line

While connecting or disconnecting the power line, user should hold the 3-pin plug with your hand and insert the plug firmly to ensure good contact between the plug and socket. Pull the plug, but not the cable, when the plug needs to be disconnected from the mains.

#### f) Design Environments

The Mixing Block should be placed in a low-humidity, dust-free, well-ventilated room without caustic gas or powerful magnetic interference. The Mixing Block should not be operated in close proximity to water sources, such as pools and water pipes.

Never cover or obstruct the openings of the Mixing Block, which are designed for ventilation and to prevent the device's interior from becoming too hot. When a single device is running, the shortest distance between its openings and the nearest object should be at least 50cm; when two devices or more are running simultaneously, the shortest distance is 100 cm among these machines. Do not place the device on a soft surface, because that will result in adverse ventilation near the device's bottom openings.

Too high temperature will result in degraded performance or failure of the Mixing Block. Therefore, the device should be protected against any kind of heat sources like sunlight, ovens, or central heating equipment.

If the Mixing Block is set aside for a long time, it is recommended to disconnect the power line from the mains and cover the device with a piece of soft cloth or plastic to prevent against dust.

---

**Note:** Once one of the following events occurs, you are advised to disconnect the power cable from the mains, and contact the distributor or ask a certificated maintenance worker for help.

- Liquid enters into the device;
  - The device is sprinkled or drenched;
  - The device malfunctions, giving off an abnormal sound or odor;
  - The device falls onto the floor or its shell is damaged;
  - Significant changes in the device's performance
-

### 3 LABELS

#### a) Tablet

For Model MB-101 :

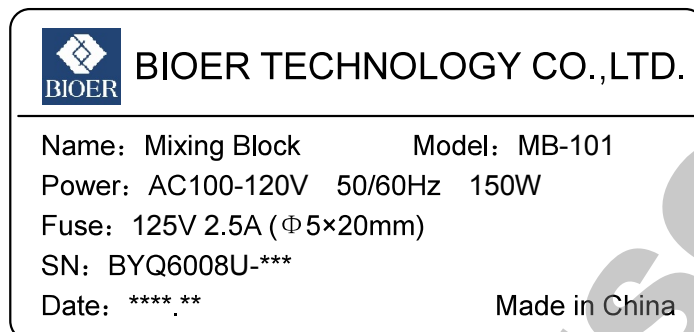

For Model MB-102:

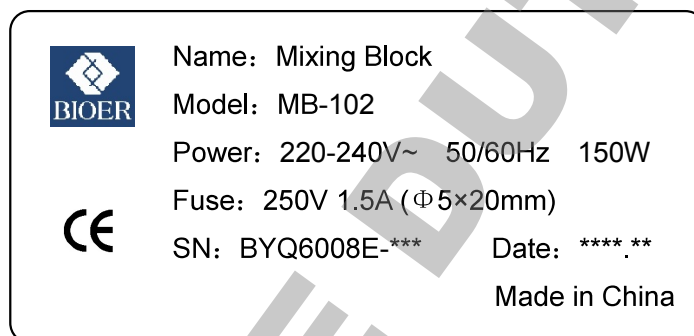

#### b) Warning Sign

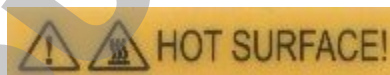

**Warning!** There is one warning sticker reading 'HOT SURFACE!' on the instrument. During the program execution or in the short period after the program execution, the metal part near those signs is forbidden to be touched by any part of the body for fear of the body burn!

### 4 BLOCK INSTALLMENT AND INSTRUMENT MAINTENANCE

The machine has accessories as below: Inner-Hexagon round head screw bolt, Spring Washer and L Type Spanner. Please use L Type Spanner to tighten four pieces bolts and Spring Washer when fixing or changing block. Don't overexert and make sure that each bolt is fastened.

The conical holes over the block should be cleaned regularly with soaked cotton swab in order to ensure sufficient contact and thus good heat conduction between each conical hole and the tube inside it.

In case it is smeared, the surface of the unit can be scrubbed with a piece of dehydrated soft wet cloth.

---

**Warning!** When cleaning or changing blocks, the instrument should be powered off.  
Do not start up shaking before installing block.  
Corrosive scour is not allowed to clean the surface of the instrument.

---

## 5 WARRANTY AND SERVICE INFORMATION

### a) Warranty

The unit is warranted for a period of one month, from the date of shipment from Bioer Co., to be free from defects in material and workmanship. Bioer Co. shall be obligated, under this warranty, to exchange the unit that proves to be defective as described herein.

The unit is also warranted for a period of twelve months, from date of shipment from Bioer Co., to be free repaired for defects in material and workmanship. The Bioer's obligation under this warranty shall be limited to repair or exchange (at the Bioer's option) of the unit that proves to be defective as described herein.

The buyer is responsible for deliver to the maintenance shop designated by Bioer on all warranty claims. The buyer is also responsible for the transportation expenses of the freight to the maintenance shop. Bioer shall be responsible for the transportation expenses of the freight to the buyer (which is only applicable to domestic buyers).

After the warranty comes due, Bioer reserves the right to charge cost price for maintenance of a defective device.

### b) Warranty Terms

The above warranty is not applicable to defective devices with incorrect use, abnormal operating conditions, improper application, and unauthorized maintenance or alteration.

*Bioer makes no express warranties other than those that are described herein. Any descriptions in sales promotion under specific conditions shall not create an express warranty that the goods shall conform to such description.*

---

**Note:** Once it is opened, the package should be checked according to the packing list. If the buyer finds any items to be missing or damaged, do not hesitate to contact the distributor.  
After the acceptance check is passed, the buyer should fill out the check form and send its photocopy (or fax it) to the distributor. Bioer establishes the archives and maintenance records with the returned form.  
Please store the package and packing materials in a safe place in case of future device maintenance. The above warranty does not extend to goods damaged as the result of cheesy package.

---

## CONTENTS

CHAPTER 1	INTRODUCTION	1
CHAPTER 2	SPECIFICATIONS	2
CHAPTER 3	PREPARATIONS	4
1	STRUCTURE DESCRIPTION	4
2	DIAGRAM OF DISPLAY PANEL	5
3	BUTTON EXPLANATION	5
CHAPTER 4	OPERATION GUIDE	6
1	PRE-CHECK BEFORE TURN ON POWER	6
2	SET UP OF TEMPERATURE, VIBRATION TIME AND VIBRATION SPEED.	6
3	SPOT VIBRATION	7
4	CORRECT TEMPERATURE DISCREPANCY	8
5	BUZZ SET UP	10
CHAPTER 5	TROUBLESHOOTING AND REPAIR	12
APPENDIX 1:	MODEL MB-101 WIRING DIAGRAM	14
APPENDIX 2:	MODEL MB-102 WIRING DIAGRAM	16

## CHAPTER 1 Introduction

As one kind of Cooling & Heating Block controlled by microcomputer, the Mixing Block can be equipped with many kinds of block, so as to fit for various kinds of tubes. Its wide application includes sample storage, storage and reaction of various kinds of enzyme, DNA amplification, pre-denaturation of electrophoresis, serum solidification, and so on. The Mixing Block has features as below:

- ◆ VFD display with high-luminosity;
- ◆ Temperature setting value and practical value displayed simultaneously;
- ◆ Display setting time and practical time simultaneously;
- ◆ Aluminum block protecting the sample from contamination;
- ◆ Aluminum block easily replaced, cleaned, sterilized and suitable for different type of tubes;
- ◆ Internal over-temperature protection improving reliability;
- ◆ Warning function after running is over;
- ◆ Temperature bias calibration

## CHAPTER 2 SPECIFICATIONS

This chapter addresses the Mixing Block's operation, transportation & storage conditions, basic parameters and performance.

### 1 NORMAL OPERATING CONDITIONS

Ambient temperature: 10°C ~ 30°C

Relative humidity: ≤70%

Power supply: AC100-120V 50/60Hz 150W (for model MB-101)

AC220-240V 50/60Hz 150W (for model MB-102)

Placement table-board: stable and horizontal

---

**Note:** Before power-on, please check whether the above operating conditions are satisfied. Pay special attention to the power cable's reliable grounding and make sure whether the placement table-board is stable and horizontal.

---

### 2 TRANSPORTATION AND STORAGE CONDITIONS

Ambient temperature: -20°C ~+55°C

Relative humidity: ≤80%

### 3 Basic Parameters

Parameters \ Model	MB 101 / MB-102
Standard Block	A: 40 × 1.5ml
Optional Block	B: 54 × 0.5ml
	C: 96 × 0.2ml
	D: 24 × Φ15mm Glass tube
	H: 40 × 0.2ml
	G: 26 × 0.5ml + 24 × 1.5ml
	J: 96 well ELISA plate block



Dimension(mm)	328×166×249(L×W×H)
Weight (kg)	8.5

**Note:** The aluminum block can be customized to the user's request. Please contact the distributor for your customized aluminum block.

#### 4 Performance

Temperature setting range:	0 ~ 105°C
Temperature control range	room temperature -14°C ~ 100°C
Timing Range	1 min ~ 99h59min
Cooling Time	from room temperature to room temperature - 10°C: ≤ 8min from 100°C to room temperature+10°C: ≤15min
Heating time	≤ 12min (from 20°C to 100°C)
Temperature accuracy	≤ ± 0.5 °C
Temperature Uncertainty	≤ ± 0.5 °C
Heating Rate	about 6°C /min (from 20°C to 100°C)
Block temperature uniformity	≤ ± 0.5 °C
Mixing Rate	300 ~ 1500rpm
Amplitude	3mm

## Chapter 3 Preparations

This chapter introduces the Mixing Block's mechanical structure, the keyboard and each key's functions, and some preparations before power-on. It should be read carefully before the Mixing Block is first operated.

### 1 Structure Description

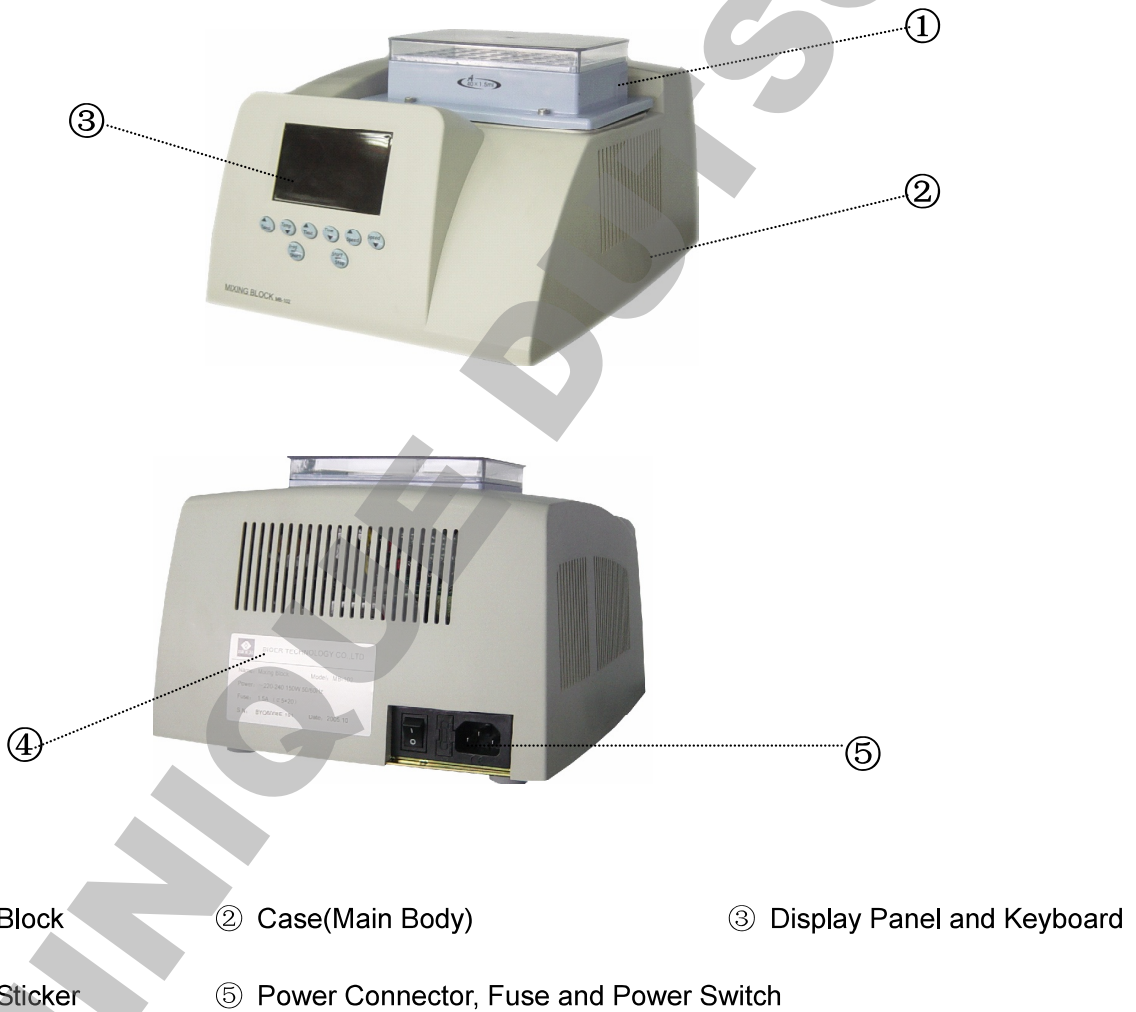

## 2 Diagram of display panel

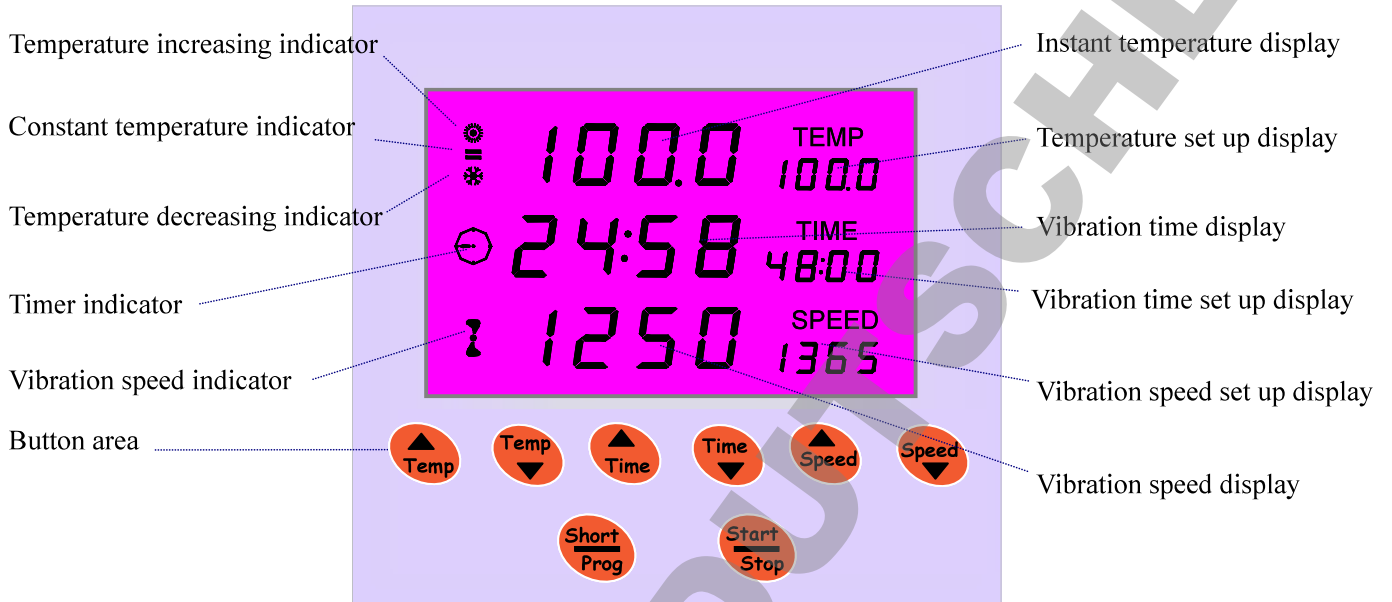

## 3 Button explanation

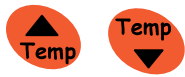

Temperature set up button. Press “▲” or “▼” to adjust the value and set the requested temperature. Keep pressing “▲” or “▼” may help to speed up the setting time.



Vibration time set up button. Press “▲” or “▼” to adjust the value and set the requested vibration time. Keep pressing “▲” or “▼” may help to speed up the setting time.



Vibration speed set up button. Press “▲” or “▼” to adjust the value and set the requested vibration speed.



Instant spot vibration button. Press it to start spot vibration. The running speed is the highest vibration speed. It is also a function button for temperature calibration



Start button or stop button.. Press this button to start or stop the mixing of the device.(valid for only mixing)

## Chapter 4 Operation Guide

This chapter gives a through instruction to the temperature set up, vibration time set up, vibration speed set up of this instrument. It also explains how to correct the discrepancy between the actual temperature and displayed temperature, and how to set up the buzzer.

### 1 Pre-check before turn on power

Before turn on power, check and confirm the following items first:

1. Whether the placement table-board is stable and horizontal;
2. The voltage should comply with the spec; (Refer to Chapter 2 for the power supply spec);
3. The power plug should be tightly plugged into the outlet;
4. The ground connection should be reliable;
5. The module connection should be reliable.

---

**Warning!** If the display is abnormal when the power is turned on, please shut down immediately and contact the supplier.

---

☺ Are you ready? Let's start!

### 2 Set up of temperature, vibration time and vibration speed.

a) Approximately 5 seconds later after the power is on, the monitor will display a temperature of 28.5, which is the instant temperature of the module. The display of "TEMP 100.0" is the set up temperature of last time, the display of "TIME 80:00" is the set up vibration time of last time, and the display of "SPEED 1000" is the vibration speed of last time.

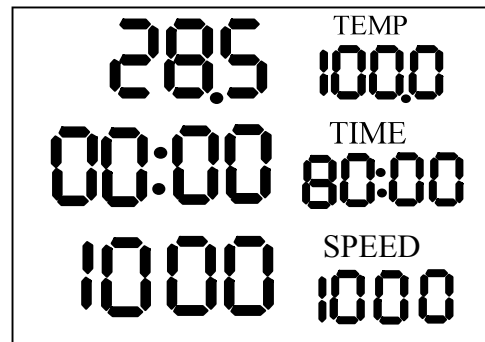

At same time, the device will automatically heat or cool, to achieve the setting temp. point.

b) The digits of the TEMP display may be reduced or increased by pressing “Temp” or “Temp” respectively.

The digits of the TIME display may be reduced or increased by pressing “Time” or “Time” respectively.

Press the above mentioned buttons for more than 3 seconds to set up the exact value.

If the temperature should be set at 40° and the time should be set up at 60:00, then press the “Temp” and not release to see the number reducing; When the number shows 40, release the button, and it will be automatically saved in 3 seconds. Next press the “Time” and not release to see the number reducing; when the number shows 60:00, release the button, and it will be automatically saved in 3 seconds.

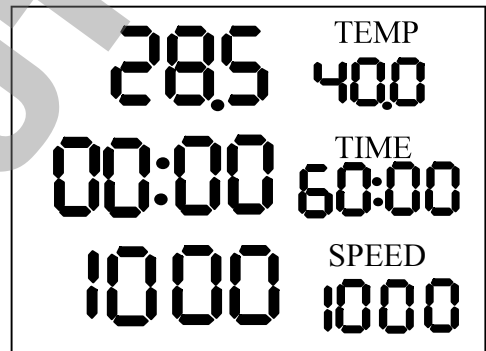
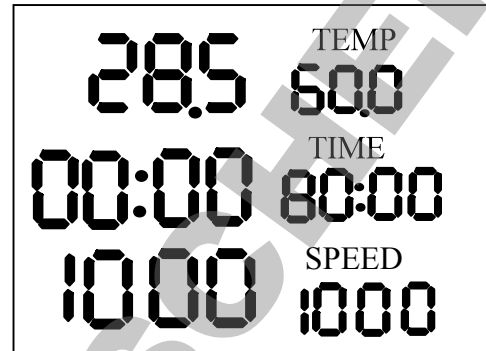

c) Press “Speed” or “Speed” to set up for the speed. The number will increase or reduce at a rate of 50rpm, release the button when the number reaches exact value, and it will be automatically saved in 3 seconds.

When set up is done, press “Start/Stop” to start mixing.

**Note:** After the setting value of temperature is saved successfully, the device will automatically heat or cool, to achieve the setting temp. point.

### 3 Spot vibration

Press “Short/Prog” to start instant vibration or short term vibration. Press the button to start it and release the button to stop it. The running speed of spot vibration is the highest vibration speed.

#### 4 Correct temperature discrepancy

The temperature of the instrument has been calibrated before shipment. However, due to certain reason, there might be discrepancy between the actual temperature and displayed temperature. On such case, you may use calibration button to correct the discrepancy.

- Note!**
1. To ensure the accuracy of the temperature, please wait for at least 30 minutes after the instrument is set at a constant temperature, and then perform the calibration.
  2. Please use certified standard class two mercury thermometer to calibrate this instrument.
  3. Calibration point: Center hole of the module. Please fill the hole with paraffin oil and immerge the thermometer bulb in it.

The method of the temperature calibration of this instrument is two-point linear calibration. The calibration point may be set freely, and by setting the second calibration point the same as the first calibration point, you can adjust the calibration point to one temperature point.

For two-point calibration, if set the two points at 40°C and 100°C, then other temperature points will be automatically adjusted per the linear relationship of the two calibration points.

Please read the following operation instruction:

a) Press both “Temp” and “Temp” at the same time, and the display will show the set up value of last time (for example 20°C) and the cursor of the first calibration point; C-1;

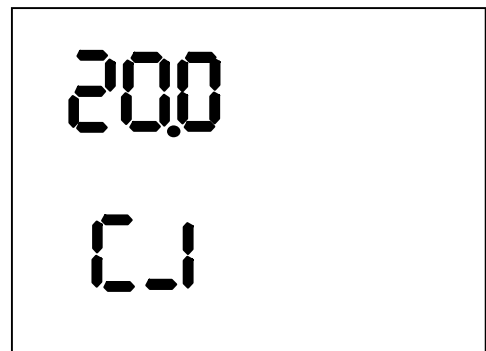

b) Press the temperature set up button “Temp” or “Temp” to set up the first calibration temperature such as 40°C;

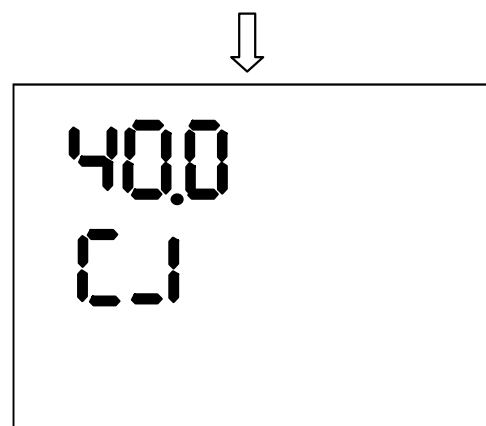



c) Perform the same operation again to set up the second calibration temperature such as 100°C;

**Note:** when setting up the temperature points, an order of low temperature point first and high temperature after is recommended. If on the case high temperature point is set first and low temperature is set after, then when performing the following actual calibration, please follow the order of low temperature first and high temperature after.

d) Press both “Temp 

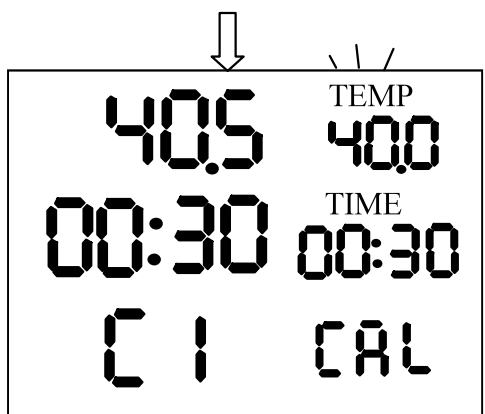
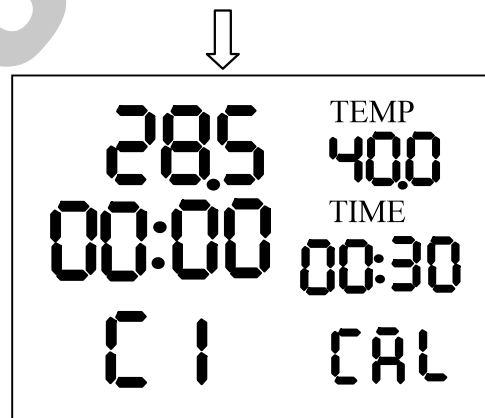
A screenshot of the instrument's LCD display. The top line shows '100.0' and the bottom line shows 'C.2'. A downward arrow is positioned above the display.



When the calibration of 40°C is done, press “  ” to exit; at this time the calibration of 40°C is ineffective.

When the calibration is done for once at both 40°C and 100°C, check for the discrepancy between the two calibration points and the actual temperature points. It should be within 0.5°C. If it's more than 0.5°C, please follow the above instruction and recalibrate until the request is met.

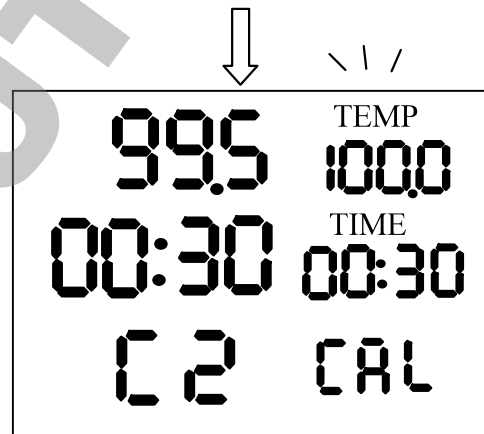
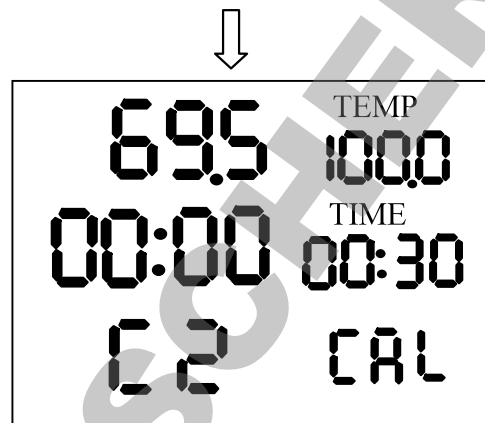



## 5 Buzz set up

**A** Upon failure's occurrence or ending, the instrument will buzz “DI, DI...” You may disable it if you do not need this function. However, the default setting is to have it on.

**B** This instrument has keyboard beep; once the button is pressed, it will beep “DI.” You may disable it if you do not need this function. However, the default setting is to have it on.





Please read the following operation instructions:

a) Press both “” and “” at the same time, and the display will show On, Beep;





b) Press “” for once and change On to OFF;

c) Press “” and “” at the same time to save the setting, and buzz will be disabled upon failure's occurrence or ending.



The display will then show the keyboard beep status.

If the display will show On K\_S. Press “” once and change On to OFF;

d) Then press both “” and “” at the same time to save the setting, and keyboard beep will be disabled.

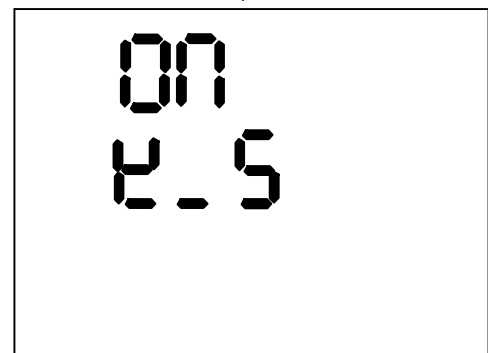

If you want to exit during set up, you may press “”, and the setting will be ineffective.

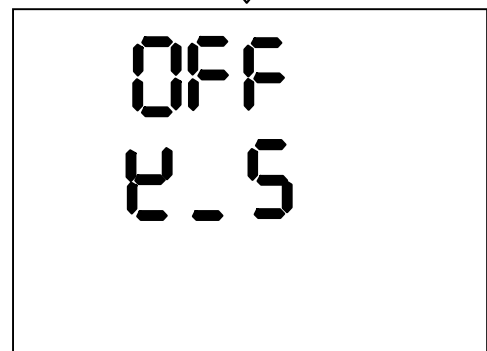

## Chapter 5 Troubleshooting and Repair

This chapter explains the main possible faults of this instrument; it also gives you instruction to the cause analysis and teaches you how to resolve the trouble.

### 1 Troubleshooting and Repair

No.	Problem	Probable Cause	Remedy
1	No display shown in the monitor when the power is on.	Power is not nected.	Check the power and connect it
		Fuse has burned out.	Change the fuse: MB 101: 125V2.5A $\Phi$ 5x20 MB 102: 250V1.5A $\Phi$ 5x20
		Switch is broken.	Change the switch
		Others	Contact the supplier of anufacturer
2	During running, the body of machine shakes tempestuously with abnormal noise.	Use improper block	Change the block (Contact supplier or manufacturer to make sure whether the block is suitable.)
		The placement table-board is unstable or uneven.	Change the placement table-board, thus to ensure the machine works on stable and horizontal table-board.
		Round feet wear and tear badly	Change round feet
		Others	Contact supplier or manufacturer.
3	Bad temperature uniformity of block	Improper installation of block	Re-install the block
		Bad cooling components	Contact supplier or manufacturer.
4	The system halted when changing block.	Bad grounding of machine	Check power cable to insure reliable grounding; Do remember to turn off the power when changing block.
5	Serious discrepancy between the actual temperature and displayed temperature	Broken sensor or bad contact	Contact the supplier of manufacturer
6	The cooling of the module drastically slows down or the temperature cannot reach blow the room temperature.	Thermoelectric cooling module is broken.	Contact the supplier of manufacturer
		Blow is broken or does not work.	

No.	Problem	Probable Cause	Remedy
7	The module is neither able to heat nor able to cool.	Temperature sensor is broken.	Contact the supplier of manufacturer.
		Thermoelectric cooling module is broken.	
8	Vibration stops	Drive is broken.	Contact the supplier of manufacturer
		Motor is broken.	
		Fuse has burned out.	Change the fuse: MB 101: 125V2.5A $\Phi$ 5x20 MB 102: 250V1.5A $\Phi$ 5x20

## 2 Disply trouble & alarm information construct

Alarm information	Trouble reason
Err 01	Temperature sensor trouble
Err 02	Memory trouble
Err 03	Motor running trouble
Err 04	Motor control transmission error

**Note:** User shall not open the cover of this instrument when under warranty; on the case when the cover does need to be opened to perform certain repair per the above instruction, please contact the supplier of manufacturer.

# Appendix 1: Model MB-101 Wiring Diagram (1/2)

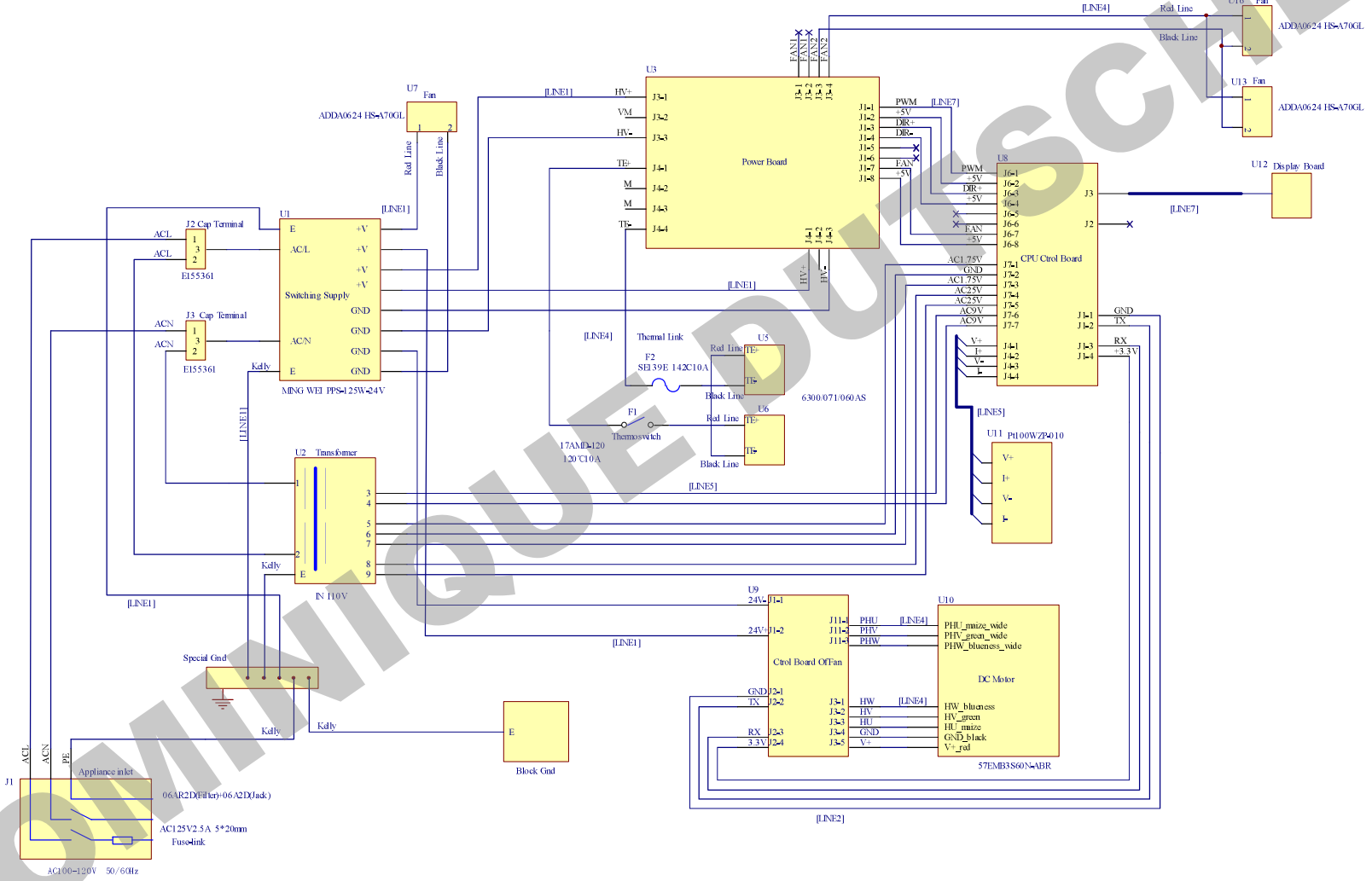

# Model MB-101 Wiring Diagram (2/2)

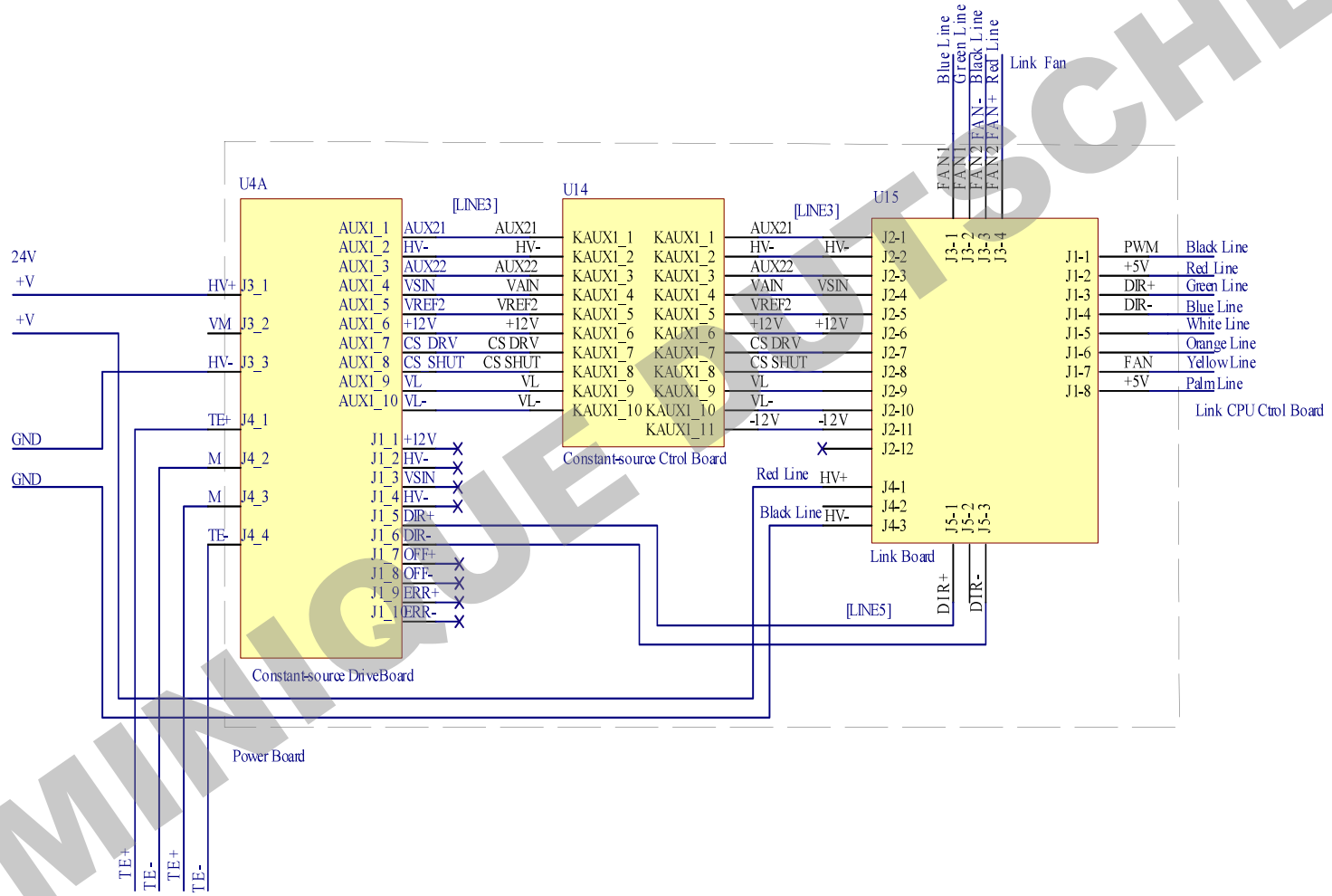

# Appendix 2: Model MB-102 Wiring Diagram (1/2)

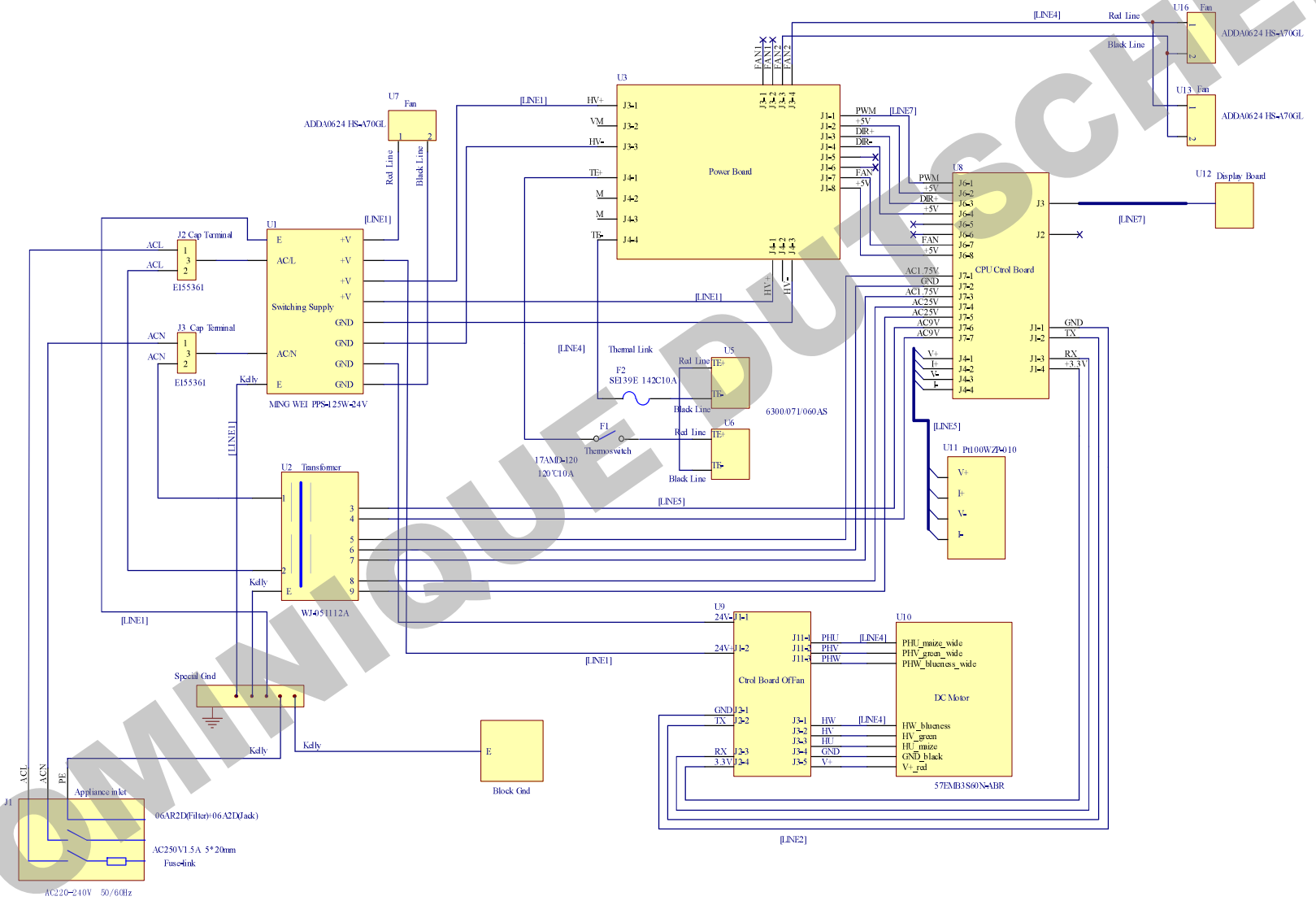

# Model MB-102 Wiring Diagram (2/2)

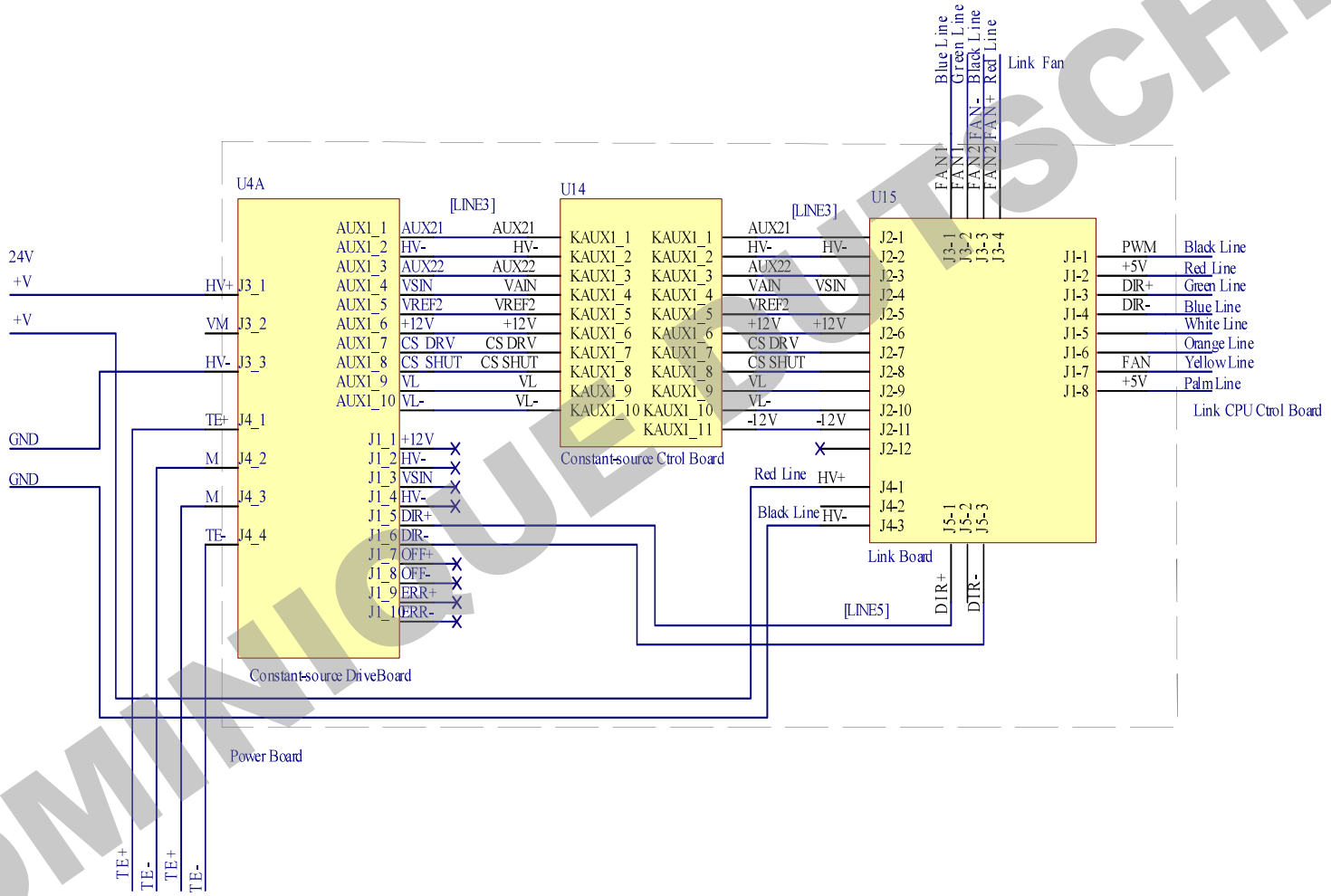

**Records**

--

DOMINIQUE DUTSCHER