

COOLING & HEATING BLOCK

CHB-202 / HB-202

CHB-201 / HB-201

User's Manual

BIOER TECHNOLOGY CO.,LTD.

Note: The Bioer Co. reserves the right to modify this manual at any time without notice.

Patent materials are included in this manual. All rights reserved. No part of this manual shall be photocopied, reproduced, or translated into other languages without written permission from the Bioer Co.

Please read this manual carefully before the Cooling & Heating Block is first operated!

File No.: BYQ60060000000E/USM

File Version: **October, 2009** **Version 4.6**

Important Note

1 Conventions

Note: Because of the important information in this column, please read it carefully. Failure to follow the advice in this column will possibly result in damage to or the malfunctioning of the Cooling Heating Block.

Warning! This symbol means that you should be cautious when performing this operation/procedure. Failure to follow the requirements in this column could possibly result in personal injury.

2 Safety

This is a class A equipment, only suitable for use in establishments other than domestic, and those directly connected to a low voltage power supply network which supplies buildings used for domestic purpose.

During the operation, maintenance, or repair of the Cooling Heating Block, the following safety measures should be taken. Otherwise, the safeguards provided by the Cooling Heating Block are likely to be damaged, the rated safety level to be reduced, and the rated operation conditions to be affected.

The Bioer Co. shall not be in any way responsible for the consequences resulting from operator's not observing the following requirements.

Note: This instrument is intended for indoor use only.

a) Grounding Considerations

A.C. power's grounding should be reliable to safeguard against an electric shock. The 3-pin plug supplied with the Cooling Heating Block's power cable is a safety device that should be matched with a suitable grounded socket. Never allow the third ground pin to be floating. If the 3-pin plug cannot be inserted, it is recommended to ask an electrician to install an appropriate power socket.

b) Keep Away from Electric Circuits

The operator is not allowed to open the Cooling & Heating Block randomly. Changing components or adjusting certain parameters inside the device must be accomplished by the certificated professional maintenance personnel only. Do not change elements while the power is still on.

c) A.C. Power Considerations

Before turning on the power, always check if the mains voltage is within the range of required power supply and that the rating current of the power socket meets the required specification as shown in below contents.

d) A.C. Power Line Considerations

As an accessory of the Cooling & Heating Block, the A.C. power supply should be the default device. If it is damaged, the A.C. power line may not be repaired, but it must be replaced with a new one. The power supply should be free of heavy objects during the Cooling & Heating Block's operation. Keep the power supply away from areas where people gather regularly.

e) Connect the A.C. Power Line

While connecting or disconnecting the power line, you should hold the 3-pin plug with your hand and insert the plug firmly to ensure good contact between the plug and socket. Pull the plug, not the cable, when you need to disconnect from the mains.

f) Design Environments

The Cooling & Heating Block should be placed in a low-humidity, dust-free, well-ventilated room without caustic gas or powerful magnetic interference. The Cooling & Heating Block should not be operated in close proximity to water sources, such as pools and water pipes.

Never cover or obstruct the openings of the Cooling & Heating Block, which are designed for ventilation and to prevent the device's interior from becoming too hot. When a single device is running, the shortest distance between its openings and the nearest object should be at least 50cm; when two devices or more are running at the same time, the shortest distance is 100 cm. Do not place the device on a soft surface, because that will result in adverse ventilation near the device's bottom openings.

Too high temperature will result in degraded performance or failure of the Cooling & Heating Block. Therefore, the device should be protected against any kind of heat sources like sunlight, ovens, or central heating equipment.

If the Cooling & Heating Block is set aside for a long time, it is recommended to disconnect the power line to mains and cover the device with a piece of soft cloth or plastic to prevent dust from entering.

Note:	Once one of the following events occurs, you are advised to disconnect the power cable with mains, and contact the distributor or ask a certificated maintenance worker for help. <ul style="list-style-type: none">● Liquid enters into the device;● The device is sprinkled or drenched;● The device malfunctions, giving off an abnormal sound or odor;● The device falls onto the floor or its shell is damaged;● Significant changes in the device's performance
--------------	---

g) Warning Sign



Warning!	There is one warning sticker read 'HOT SURFACE!' on the instrument. During the program execution or in the short period after the program execution, the metal part near those signs is not allowed to be touched by any part of the body for fear of the body burn!
-----------------	--

3 BLOCK INSTALLMENT AND INSTRUMENT MAINTENANCE

The machine has accessories as below: Inner-Hexagon Bolt, Spring Washer and special-purpose Inner-Hexagon Spanner. Please use special-purpose Inner Hexagon Spanner to tighten four pieces Inner-Hexagon Bolts and Spring Washer when fixing or changing block. Don't overexert and make sure that each bolt is fastened. You can put the Special-purpose Inner-Hexagon Spanner into the bottom bath of the unit after using.

The conical holes over the block should be cleaned regularly with soaked cotton swab in order to ensure sufficient contact and thus good heat conduction between each conical hole and the tube inside it.

In case it is smeared, the surface of the unit can be scrubbed with a piece of dehydrated soft wet cloth.

Warning!	When cleaning, the instrument should be off. Corrosive scour is not allowed to clean the surface of the instrument.
-----------------	--

4 Warranty And Service Information

a) Warranty

The unit is warranted for a period of one month, from the date of shipment from the company, to be free from defects in material and workmanship. Bioer Technology Co., Ltd shall be obligated, under this warranty, to exchange the unit that proves to be defective as described herein.

The unit is also warranted for a period of twelve months, from date of shipment from the company, to be free repaired for defects in material and workmanship. The Bioer's obligation under this warranty shall be limited to repair or exchange (at the Bioer's option) of the unit that proves to be defective as described herein.

The buyer is responsible for deliver to the maintenance shop designated by Bioer on all warranty claims. The buyer is also responsible for the transportation expenses of the freight to the maintenance shop. Bioer shall be responsible for the transportation expenses of the freight to the buyer (which is only applicable to domestic buyers).

After the warranty comes due, Bioer reserves the right to charge cost price for maintenance of a defective device.

b) Warranty Terms

The above warranty is not applicable to defective devices with incorrect use, abnormal operating conditions, improper application, and unauthorized maintenance or alteration.

c) After sales service hotline: +86-571-87774558

Bioer makes no express warranties other than those that are described herein. Any descriptions in sales promotion under specific conditions shall not create an express warranty that the goods shall conform to such description.

Note: Once it is opened, the package should be checked according to the packing list. If the buyer finds any items to be missing or damaged, do not hesitate to contact the distributor.
After the acceptance check is passed, the buyer should fill out the check form and send its photocopy (or fax it) to the distributor. Bioer establishes the archives and maintenance records with the returned form.
Please store the package and packing materials in a safe place in case of future device maintenance. The above warranty does not extend to goods damaged as the result of cheesy package.

Contents

Chapter 1 Introduction	1
Chapter 2 Specifications	2
1 Normal Operating Conditions	2
2 Transportation and Storage Conditions	2
3 Basic Parameters	2
4 Performance	3
Chapter 3 Preparations	4
1 Structure Description	4
2 Display Panel	5
3 Key Functions	5
Chapter 4 Operation Guide	6
1 Inspection before Power-on	6
2 Single temperature & timing setting	6
3 Multi-points programs setting	7
4 Temperature Calibration	8
5 Buzzer Setting	11
Chapter 5 Failure Analysis and troubleshooting	12
Annex1: Wiring Diagram (Mode: CHB-202)	13
Annex 2: Wiring Diagram (Mode: HB-202)	15

Chapter 1 Introduction

The Cooling & Heating Block is a new microcomputer-based product via Peltier technology. Its wide application includes sample storage, storage and reaction of various kinds of enzyme, DNA amplification, pre-denaturation of electrophoresis, serum solidification, and so on. The Cooling Heating Block has features as below:

- VFD display with high-luminosity;
- Temperature setting value and practical value displayed simultaneously;
- Display setting time and practical time simultaneously;
- Aluminum block protecting the sample from contamination;
- Aluminum block easily replaced, cleaned, sterilized and suitable for different type of tubes;
- Internal over-temperature protection improving reliability;
- Temperature bias calibration.

Chapter 2 Specifications

This chapter addresses the Cooling & Heating Block's operation, transportation & storage conditions, basic parameters and performance.

1 Normal Operating Conditions

Ambient temperature: 10°C ~ 30°C

Relative humidity: ≤ 70%

Power supply: ~220-240V 120W 50/60Hz /
~100-120V 120W 50/60Hz

Note: Before power-on, please check if the above operating conditions are satisfied.
Pay special attention to the power cable's reliable grounding.

2 Transportation and Storage Conditions

Ambient temperature: -20°C ~ +55°C

Relative humidity: ≤ 80%

3 Basic Parameters

Model Parameters	CHB-202/ CHB-201	HB-202/ HB-201
Standard Block	A: 40 × 1.5ml	
Optional Block	B: 54 × 0.5ml	
	C: 96 × 0.2ml	
	D: 24 × Φ15mm Glass tube	
	E: (115 × 73 × 38) mm Bath block	
	H: 40 × 0.2ml	
	G: 26 × 0.5ml + 24 × 1.5ml	

	J: 96 well ELISA plate block	
Dimension(mm)	300×200×150(L×W×H)	
Weight (kg)	3.2	2.8

Note: The aluminum block can be customized to the user's request. Please contact the distributor for your customized aluminum block.

4 Performance

Temperature range: CHB-202/ CHB-201: 0°C ~ 100°C

HB-202/ HB-201: Room temperature +5°C ~ 100°C

Timing Range: 1 ~ 99h59min

Cooling Time: ≤ 25 minutes (from 20°C to 0°C)

≤ 50 minutes (from 100°C to 0°C) for CHB-202/ CHB-201 only

Heating time: ≤ 35 minutes (from 20°C to 100°C, HB-202/ HB-201 ≤ 12minutes)

Temperature control accuracy: ≤ ±0.5 °C

Temperature display resolution: ≤ ±0.5°C

Temperature uniformity across the block: ≤ ± 0.5 °C

Note: As to HB-202/ HB-201, please operate it from low Temperature to high temperature in order.

Chapter 3 Preparations

This chapter introduces the Cooling & Heating Block's mechanical structure, the keyboard and each key's functions, and some preparations before power-on. It should be read carefully before the Cooling & Heating Block is first operated.

1 Structure Description

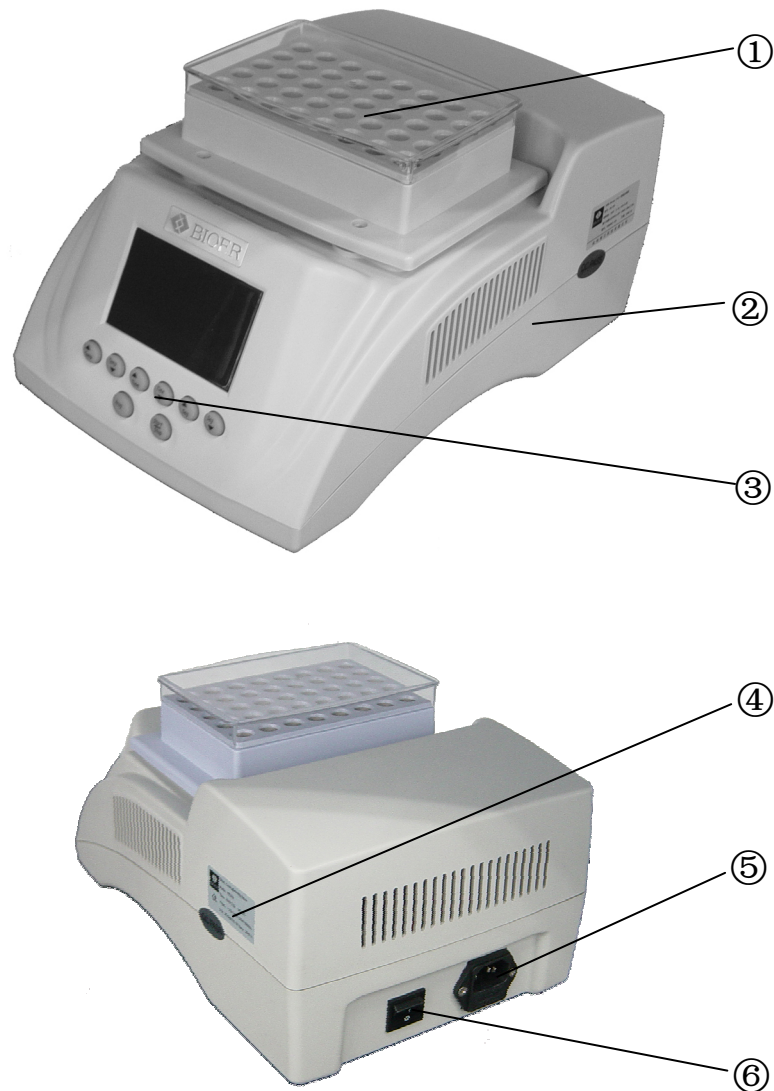

- ① Block
- ③ Display Panel and Keyboard
- ⑤ Power Connector and Fuse

- ② Case(Main Body)
- ④ Sticker
- ⑥ Power Switch

2 Display Panel

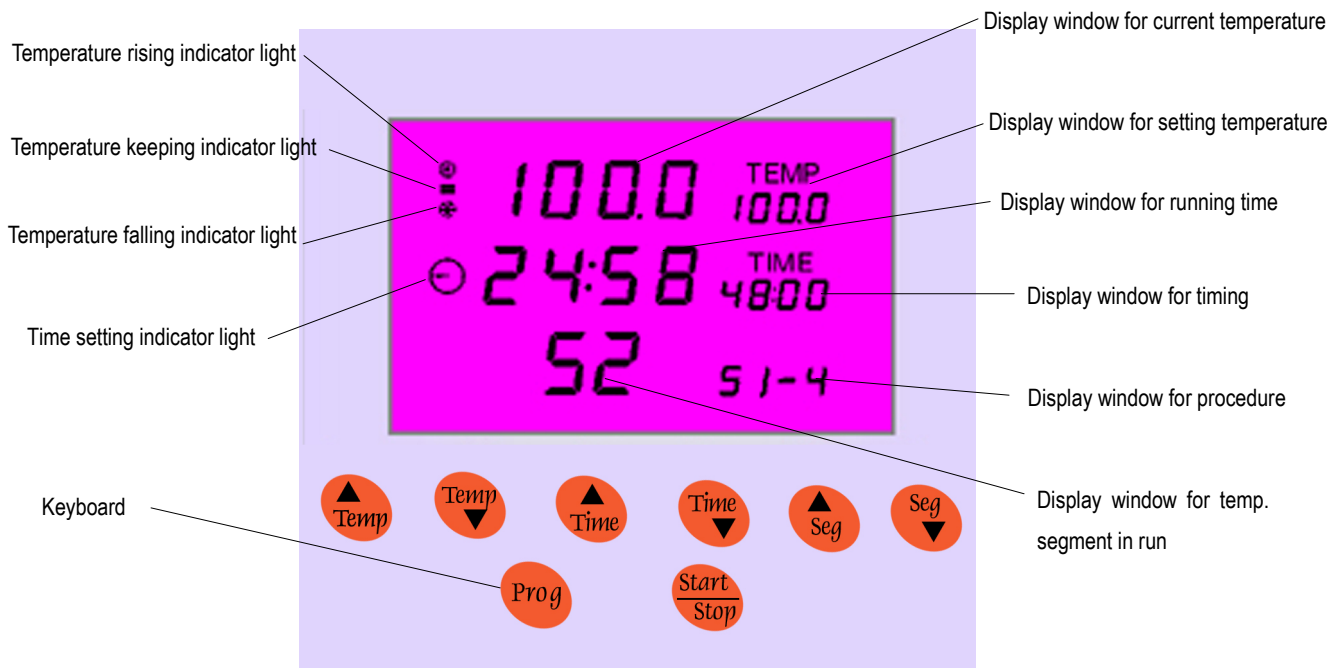

3 Key Functions



Temperature setting key, pressing “▲” or “▼” to adjust setting temperature value and set running temperature. To set temperature through pressing “▲” or “▼” continuously, which is more fast and



Timing setting key, pressing “▲” or “▼” to adjust setting timing value and set timing hours. To set timing through pressing “▲” or “▼” continuously, which is more fast and conveniently.



To select procedure section: five temperature points as S1,S2,S3,S4,S5.



Programmable setting key. Pressing “Prog” to make any section from S1 to S5 running continuously (five points as most) .



Start/stop, press this key to start or stop the procedure.

Chapter 4 Operation Guide

In this chapter, we will explain in detail how to set single point temperature, timing time and multi-points programs setting and how to correct the bias between the practical temperature value and display temperature value.

1 Inspection before Power-on

Before switching the power on, please ensure that:

- supply voltage falls within the specified limits (refer to Chapter 2);
- the plug has been inserted into the power socket reliably;
- the grounding of the power line is reliable;
- fixation between block and the main is reliable.

Warning!

Please turn off the power and contact the distributor immediately if abnormal display appears after power-on.

Are you ready? Let's begin!

2 Single temperature & timing setting

- a) Power-on for about 5 seconds, display window for practical temperature shows 28.5, which is the practical temperature of the block; Display window for setting temperature shows 100.0, which is the former temperature, while 80:00 is the former timing time, and S1 is the former temperature section.

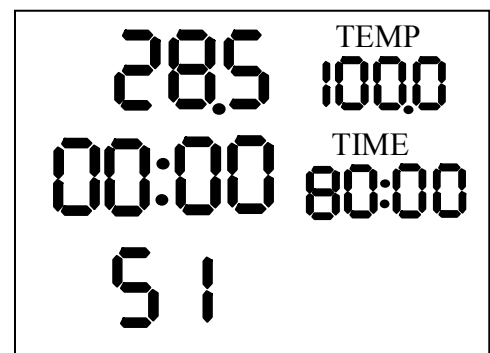

- b) Pressing “▲Temp” or “▼Temp”, the value of display window for setting temperature will reduce or increase from decimal digit, unit digit, tens digit to hundreds digit.

Pressing “▲Time” or “▼Time” to set timing time according to the same transformation rule above.

Besides, pressing “▲Temp” or “▼Temp” for three seconds continuously to amend the digit from decimal to unit, from unit digit to tens digit, from tens digit to hundreds digit quickly.

If you want to set the temperature to 40°C, timing time to 60:00, pressing “▼Temp” continuously to let the temp. reach 40°C, it will be confirmed and stored after 3 second. Meanwhile pressing “▲Time” for 60:00 continuously, it will be confirmed and stored after 3 seconds. After finishing setting section S1, pressing “Start/Stop” to run the program.

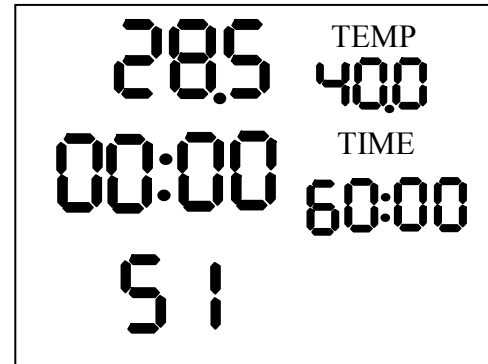

- c) Pressing “▲Seg” or “▼Seg” to set five temp. point's value from S1 to S5. Pressing “▲Seg” to select S3, then press temperature setting key and timing setting key to set the values of temperature and time according to step b). You can set the values of temperature and time from S1 to S5 according to this way, and you can set these five points as usual temperature point, whenever you want to use, you can adjust.

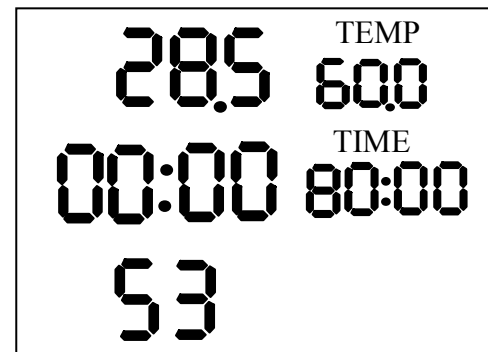

3 Multi-points programs setting

Pressing “▲Prog” can connect S1-S2, S1-S3, S1-S4, S1-S5, S2-S3, S2-S4, S2-S5, S3-S4, S3-S5, S4-S5 among S1,S2,S3,S4,S5 into two-points or multi-points temp. program.

Take setting program of S1-S4 as an example:

Pressing “Prog”, there appears *Star* in the lower right corner, then press “▲Seg” or “▼Seg” to select S1, press “Prog” again to confirm, there appears End in the lower right corner. Press “▲Seg” or “▼Seg” to select S4, then press “Prog” continuously for 3 seconds, after this, the program startup. (There’s no need to press “Start/Stop” again.)

During multi-points program, the lower right corner shows the initial point and terminal point (“Prog.” such as S1-4). This is the significant difference between the running interfaces of signal point program and multi-point program. That means single point program has no such symbol.

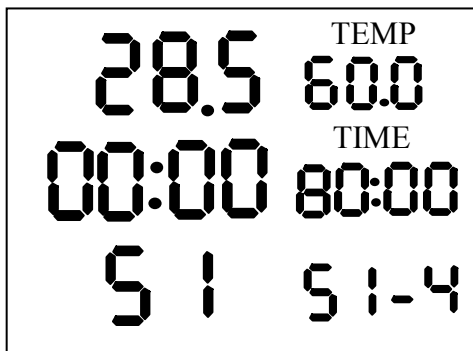
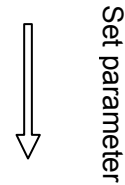
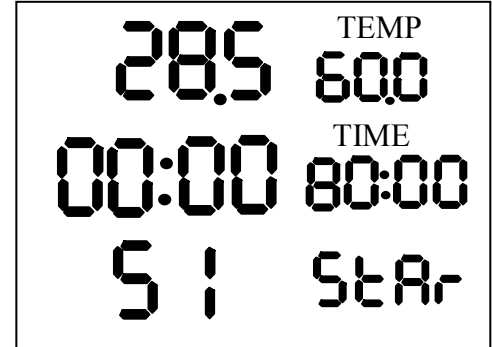

Running Procedure
←

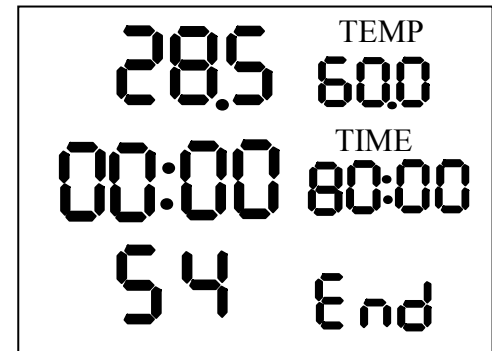

4 Temperature Calibration

The Cooling & Heating Block’s display temperature is validated before shipment from the company. However, you may correct the bias between the practical temperature and display temperature, if there is any, through the calibration key.

- Note!**
1. For reliable calibration, it is not permitted to calibrate the display temperature until it stays within the control limits of the target temperature for at least 30 min.
 2. Should adopt qualified two-class standard mercurial thermometer to regulate the instrument.
 3. Calibration point should be the wells in the center of block, to inject paraffin oil into the hole location to immerse sensor of thermometer.

The instrument regulates temperature through adopting linear calibration of two-points. The user can set the calibration point freely. In the case that the second calibration point is the same as the first one, the instrument will regulate the current temperature point.

If you adopt two-point linear calibration, if the calibration points are set as 40°C and 100°C, other temperature points will adjust according to linearity automatically.

Detailed operation method as following:

- a) Press “▲Temp” and “▼Temp” simultaneously, the temperature display will display the former setting value 20°C and prompt of first calibration point as C_1 automatically.

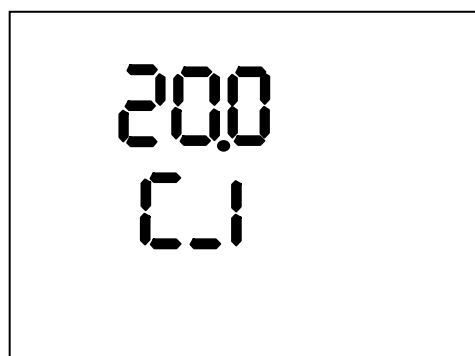



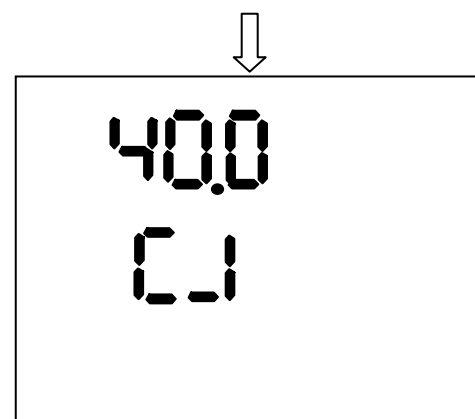

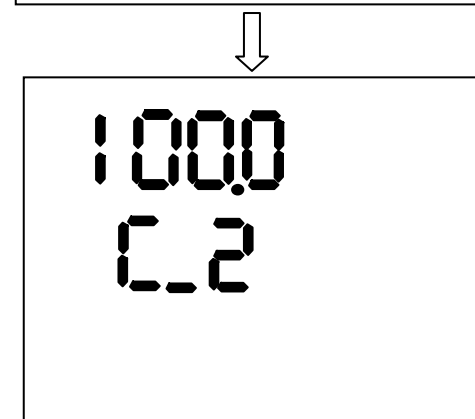

- b) Pressing “▲Temp” or “▼Temp” to set the first calibration temperature point as 40°C.



- c) Pressing “▲Temp” or “▼Temp” to set the second calibration temperature point as 100 °C.



Note: It is recommended to set calibration points from low temperature to high temperature.

- d) Press “” and “” simultaneously to enter temperature calibration interface. The temperature display window will show 40.0°C automatically, then the machine will start heating up to 40°C. Then keep timing for 30 minutes, click “”, and “TEMP” in the display window will flash. Press “” or “” to calibrate the temperature value as 40.5°C according to the value showed in the thermometer. Press “” again, the temperature display window will show 100.0°C automatically, same as above. The machine will start heating up to 100°C, Keep timing for 30 minutes, input calibration value, then press “” to confirm.

After calibrating the temperature as 40°C, press “” To quit temperature calibration interface. At this time, the calibration value 40°C is unavailable.

After calibration for one time, keep temperature points as 40°C and 100°C, calibrate the difference between these two temperature points and current temperature, which should be keep within 0.5°C. If the difference is larger than 0.5°C, please calibrate the temperature again according to the steps above till getting satisfactory value.

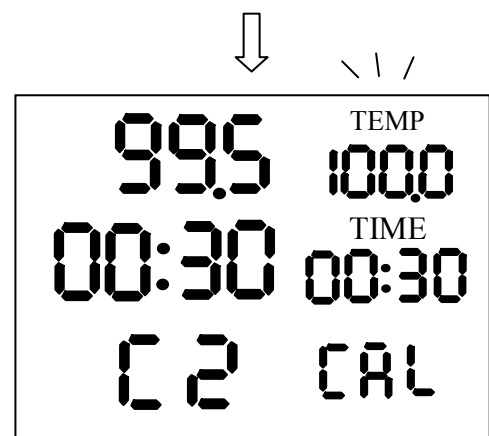
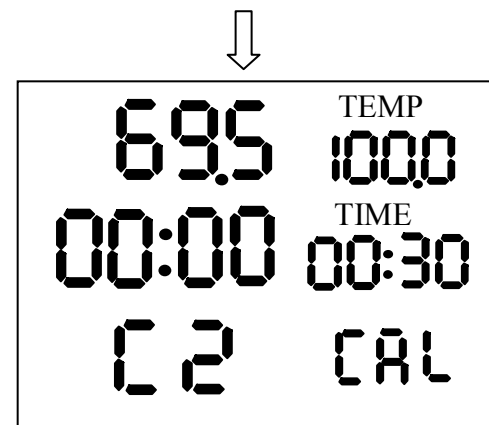
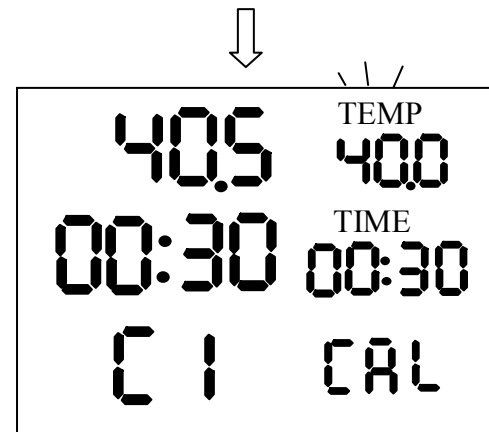
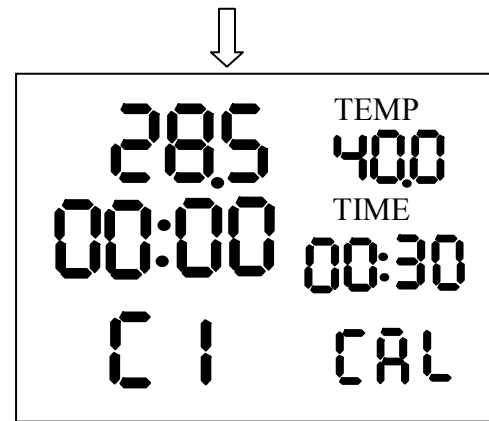



5 Buzzer Setting



The machine has default function as to remind the user when it meet troubles or finish running by beeps. The user can cancel this function.

The machine has default function to beep when users click the keys. The users can set to cancel this function.



Please operate in the following way:

a) Press “” and “” simultaneously, the display window will read: On, Beep.

b) Click “” to shift On to OFF.

c) Press “” and “” simultaneously, thus the modification will be saved, and function to remind trouble or finishing running is canceled. Meanwhile, the system will enter key buzzer setting interface.

The display window will read: On K_S, click “”, to shift On to OFF;

d) Press “” and “” simultaneously again, thus the modification is saved. During setting, you can press “” to quit the setting interface, thus the modification is unavailable.

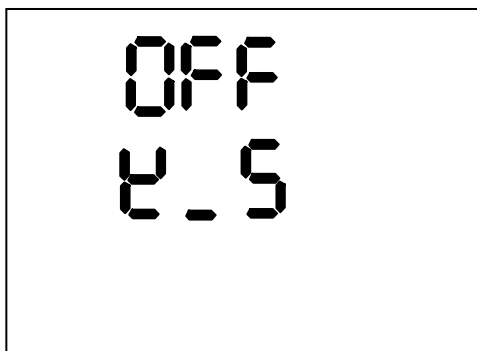
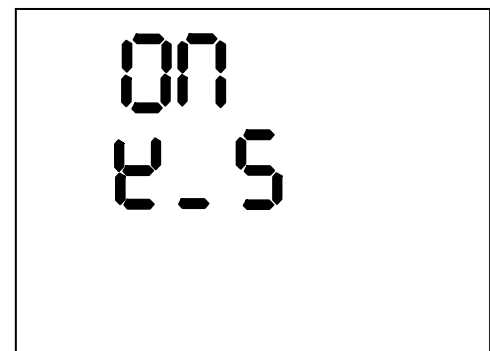

Chapter 5 Failure Analysis and troubleshooting

In this chapter, we briefly describe possible failures, their reasons analysis and way of processing.

Failure Analysis and Processing Procedures

No.	Phenomenon	Possible Causes	Processing Procedure	Note
1	Display window doesn't response after power-on	Power supply disconnected	Check power supply for correct connection	Customer can change it with a right fuse.
		Bad fuse	Replace it (250V 2.5A Φ 5×20 / 125V 2.5A Φ 5×20)	
		Switch failure	Replace it	
		Other	Contact distributor or manufacturer	
2	Serious mismatch between the practical and display temperatures	Sensor failure or bad contact	Contact distributor or manufacturer	
3	There is significant change in cooling speed, or unavailable temperature below ambient temperature.	Cooling module failure	Contact distributor or manufacturer	This phenomenon is normal for CHB-202/CHB-201.
		Fan failed or stopped	Contact distributor or manufacturer	
4	Neither cooling nor heating	Sensor failure	Contact distributor or manufacturer	Only for CHB-202/CHB-201.
		Cooling module failure	Contact distributor or manufacturer	

Note: During the warranty period, the user is not allowed to open the Cooling & Heating Block. If there is a need to open the device for an above failure, Please contact the distributor or manufacturer immediately.

Annex1: Wiring Diagram (Mode: CHB-202)

For 220V instrument:

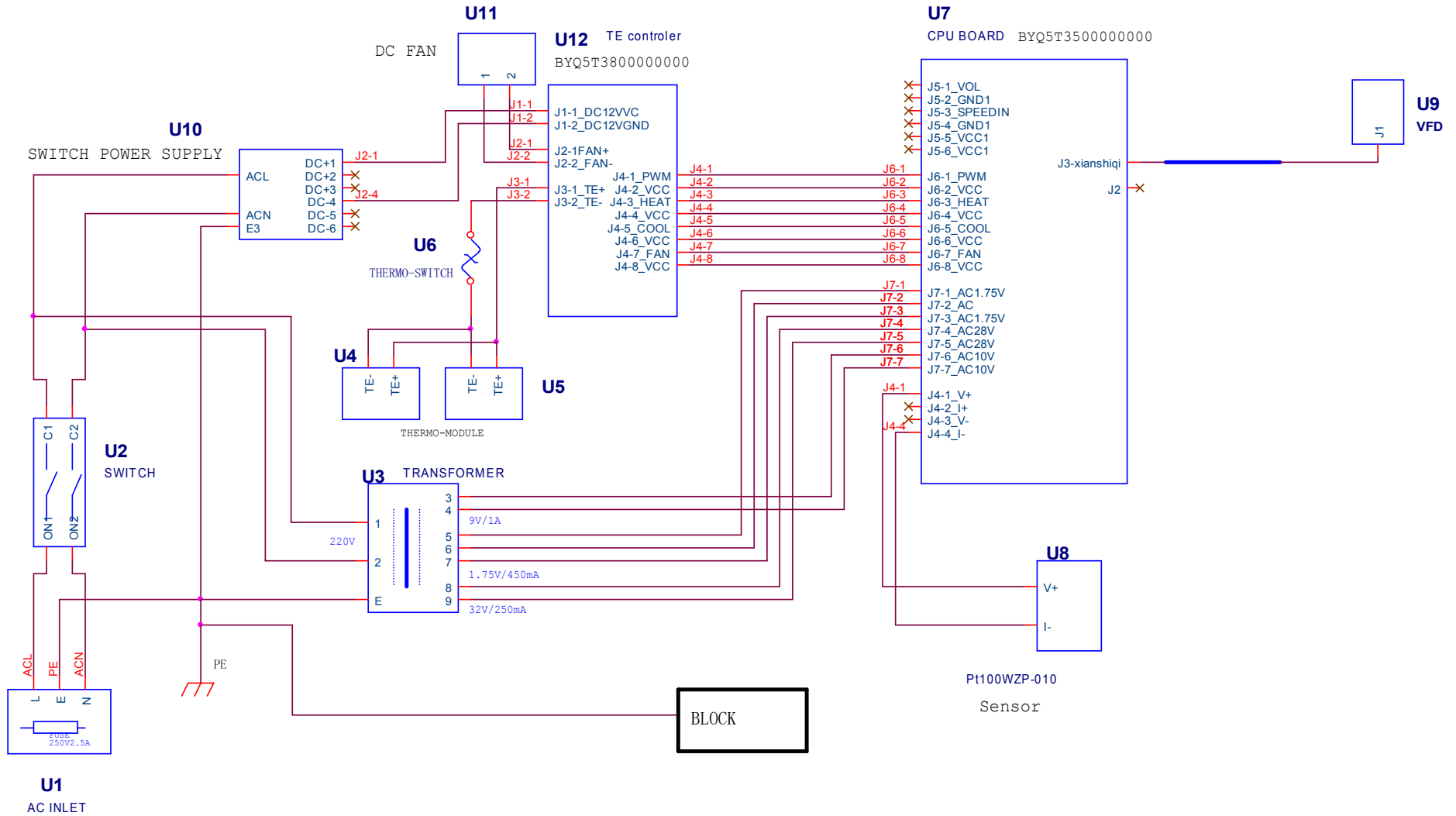

Annex 2: Wiring Diagram (Mode: HB-202)

For 220V instrument:

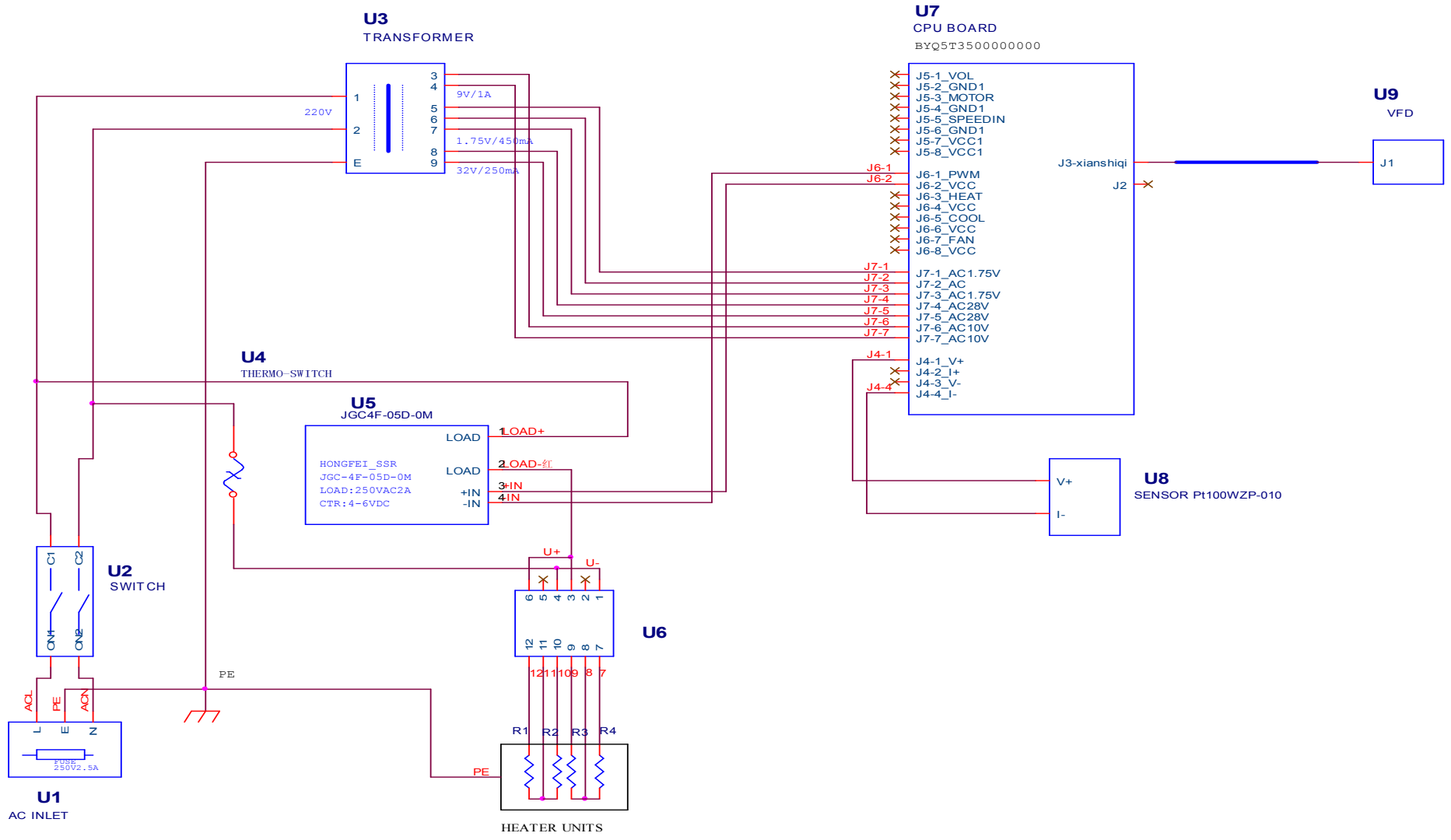

For 110V instrument:

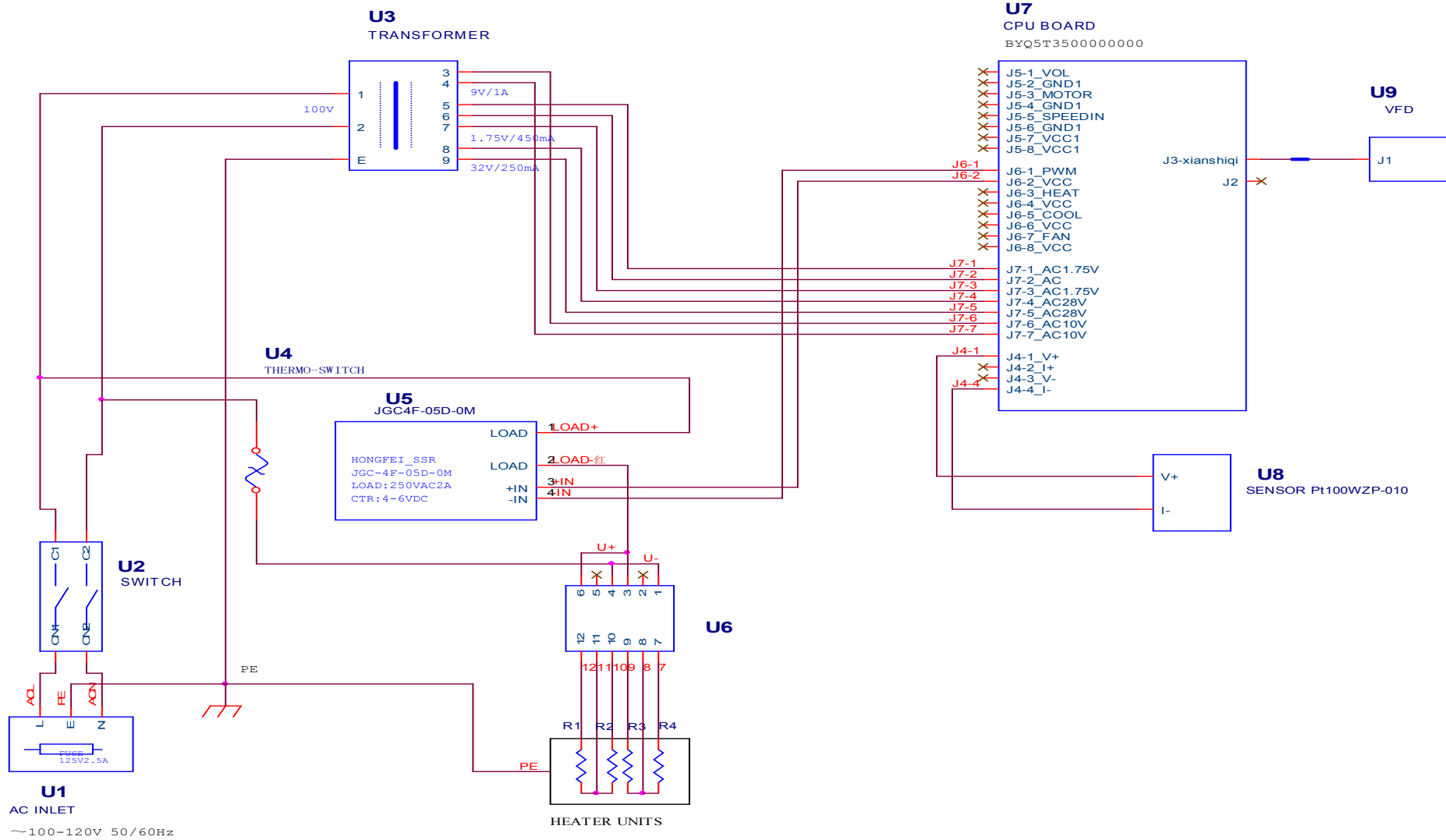

Note:

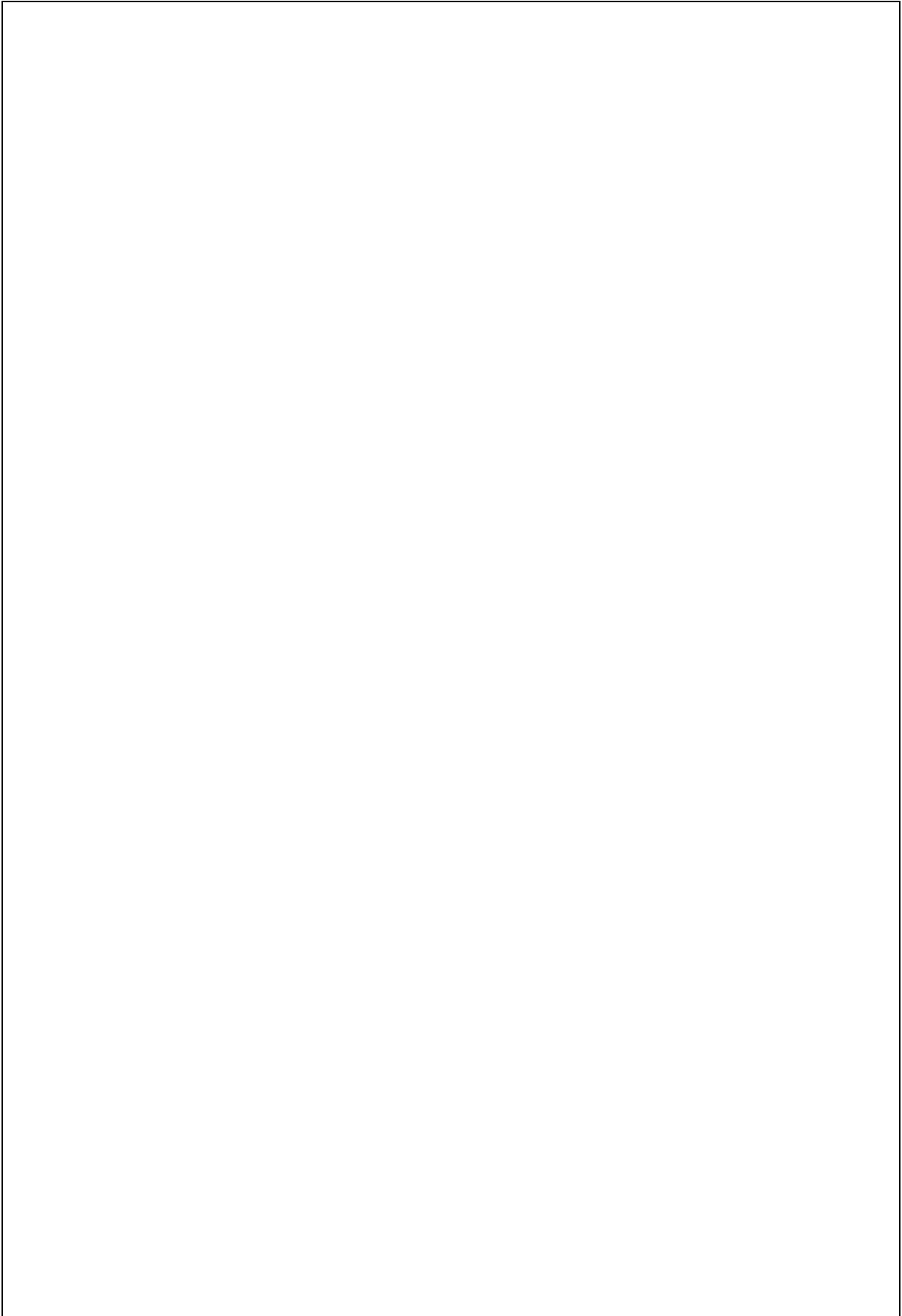
A large, empty rectangular box with a thin black border, intended for a note or comment. It occupies most of the page's vertical space below the 'Note:' label.