

Sartolab® RF | BT Vacuum Filtration Units

Best Engineered to Meet Today's
Highest Requirements

User Benefits

- Highest flow rates with a large filtration area
- No loss of protein with a low protein affinity membrane
- Low hold-up volume due to an optimized membrane support
- Can be used as stand-alone system or with the Sartolab® Multistation, which allows parallel filtration of up to 6 samples



Product Information

Sartolab® RF | BT vacuum filtration units are convenient filtration units designed for research purposes and, therefore, for the filtration of small volumes from > 50 mL to 1 L. Sartolab® RF as a complete system includes a receiver flask to the filtration funnel. Sartolab® BT is a bottle top filter (filtration funnel) without a receiver flask, enabling customers to use their own receiver flasks and/or to expand the filtration capacity, depending on the particle load of the filtered liquid, by filling more than one receiver flask.

Membrane of Choice

Polyethersulfone is the membrane of choice for the Sartolab® RF | BT vacuum filtration units as it combines very low protein binding properties and highest flow rates. The 0.22 µm polyethersulfone membrane belongs to the best asymmetric membrane in the market.

The Sartolab® RF | BT vacuum filtration units are available in 3 different pore sizes to meet most of the applications:

- 0.1 µm for mycoplasma removal
- 0.22 µm for the sterile filtration of cell culture, media, buffers, and reagents
- 0.45 µm for the clarification of aqueous and viscous solutions

Ergonomic Design

Sartolab® RF | BT vacuum filtration units have been designed to maximally facilitate the user's daily work.

- Ergonomic design of the 150 mL to 1 L bottles for easy grip with one hand and designated writing field on the back for clear labeling of samples
- Engraved graduations on the funnels and the bottles ensure accuracy and highest readability
- The footprint of the bottles gives good stability for the unit during filtration
- No extra tightening of the funnel before filtration required (vacuum-tight sealed)
- The funnels and bottles are stackable to save space not only in the refrigerator but also in the bin
- The design of the yellow adapter connecting the funnel to the bottles enables the filtration unit to be used on the Sartolab® Multistation for filtration of up to 6 samples in parallel with one vacuum source
- The ergonomic soft blister packaging is not only easy to open but its design facilitates the transportation of several units with one hand

State-of-the-Art Production

- Sartolab® RF | BT vacuum filtration units are manufactured in an ISO 13485 certified plant and ISO Class 8 cleanroom to assure the highest level of purity
- All fluid path materials used in the production of the Sartolab® RF | BT vacuum filtration units are medical graded for highest quality, without any animal origin
- All products are sold sterilized and guaranteed endotoxin-free
- All fluid path component materials meet the requirements for United States Pharmacopeia (USP) Class VI Biological Test for Plastics, latest volume
- The fluid path component materials are determined to be non-cytotoxic in accordance to ISO 10993

Best Engineering

- Optimized membrane support for lowest hold-up volumes and for the reducing of foam formation and thus a denaturation of proteins
- Delivered with a vacuum tube connector for stand-alone filtration
- For the Sartolab® RF versions, the screw caps of the bottles are delivered extra packed to maintain sterility up to the end of filtration
- The 45 mm neck thread of the Sartolab® units ensures a vacuum-tight seal to bottles with this standard thread
- The risk of contamination is minimized with the complete ready-to-use unit Sartolab® RF versions

Comparison of Filtration Times [s] for 500 mL Cell Media + 10% FBS in Six 0.22 µm 500 mL Vacuum Filtration Units

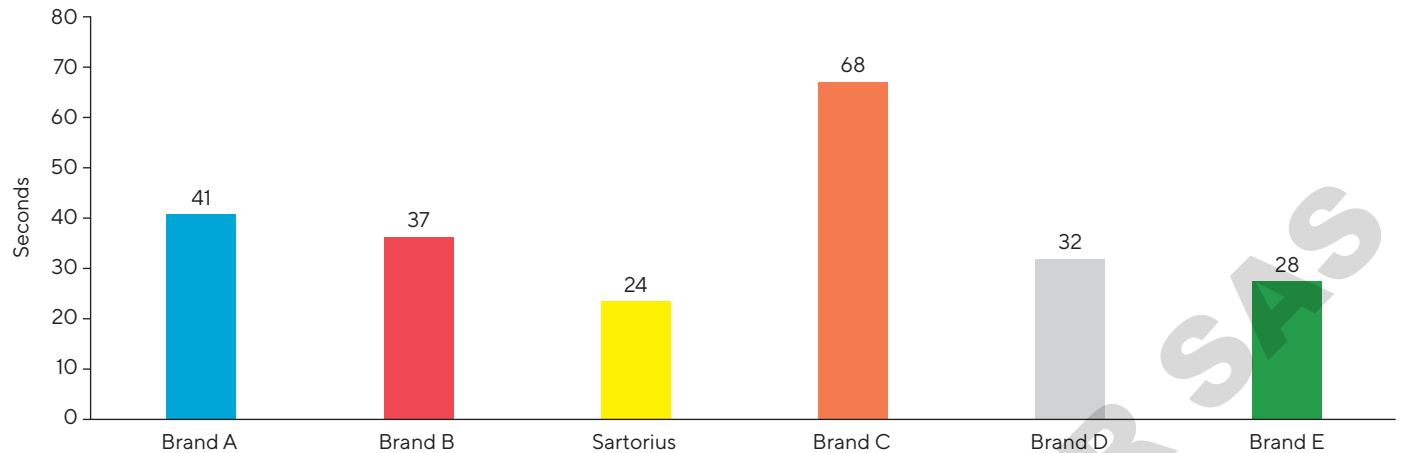

Technical Specifications

Material

Membrane filter	0.1 µm polyethersulfone (Cat. No. 180D*) 0.22 µm polyethersulfone (Cat. No. 180E*) 0.45 µm polyethersulfone (Cat. No. 180F*)
Funnel, lid, and bottle	Polystyrene (PS)
Tubing connector, funnel adapter, and screw cap	High Density Polyethylene (HDPE)
Packaging	PET PE and PE PA multilayer films

Specifications

Membrane diameter	80 mm for 150 mL and 250 mL volumes 100 mm for 500 mL and 1,000 mL volumes
Effective filtration area	43 cm ² for 150 mL and 250 mL volumes 69 cm ² for 500 mL and 1,000 mL volumes
Bottle neck size	45 mm
Autoclavable	No
Sterilization method	E-Beam (beta) irradiation (SAL 10 ⁻⁶)
Transportation and storage temperatures	-20° C to + 60° C
Operational temperatures	0° C to 70° C
Packaging	Single-packaged, soft blister, sterile
Operating pressure	-350 to -750 mbar
Hold up volumes (for water)	2.7 mL for 150 mL and 250 mL versions 4.1 mL for 500 mL and 1,000 mL versions

Ordering Information

Sartolab® RF

The Sartolab® RF vacuum filtration unit is comprised of:

- A graduated funnel with a polyethersulfone (PES) membrane, a vacuum adapter and a lid
- A bottle, with graduation and writing field
- A tube connector for vacuum connection (for stand-alone filtration)
- A screw cap for storage of the filtrate (individually wrapped to maintain sterility)

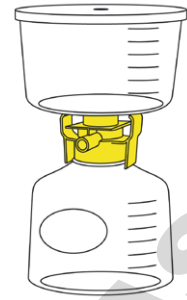

Cat. No.	Description	Membrane Type	Pore Size	Funnel Volume (mL)	Bottle Volume (mL)	Packing Unit
180E02-----E	Sartolab® RF 150	Asymmetric PES	0.22 µm	150	150	12
180F02-----E	Sartolab® RF 150	PES	0.45 µm	150	150	12
180D03-----E	Sartolab® RF 250	PES	0.1 µm	250	250	12
180E03-----E	Sartolab® RF 250	Asymmetric PES	0.22 µm	250	250	12
180F03-----E	Sartolab® RF 250	PES	0.45 µm	250	250	12
180E04-----E	Sartolab® RF 500	Asymmetric PES	0.22 µm	500	500	12
180F04-----E	Sartolab® RF 500	PES	0.45 µm	500	500	12
180D05-----E	Sartolab® RF 1,000	PES	0.1 µm	1,000	1,000	12
180E05-----E	Sartolab® RF 1,000	Asymmetric PES	0.22 µm	1,000	1,000	12
180F05-----E	Sartolab® RF 1,000	PES	0.45 µm	1,000	1,000	12

Sartolab® BT

The Sartolab® BT bottle top filter is comprised of:

- A graduated funnel with a polyethersulfone (PES) membrane, a vacuum adapter, and a lid
- A tubing connector for vacuum connection (for use as stand-alone)

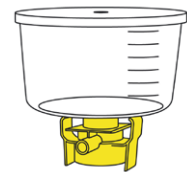

Cat. No.	Description	Membrane Type	Pore Size	Funnel Volume (mL)	Packing Unit
180E12-----E	Sartolab® BT 150	Asymmetric PES	0.22 µm	150	12
180E13-----E	Sartolab® BT 250	Asymmetric PES	0.22 µm	250	12
180E14-----E	Sartolab® BT 500	Asymmetric PES	0.22 µm	500	12
180E15-----E	Sartolab® BT 1,000	Asymmetric PES	0.22 µm	1,000	12
180F15-----E	Sartolab® BT 1,000	PES	0.45 µm	1,000	12

Accessories and Consumables

Multistation

For hands-free parallel filtration of up to six samples

Cat. No.	Description	Packing Unit
SDLCO1	Sartolab® Multistation	1

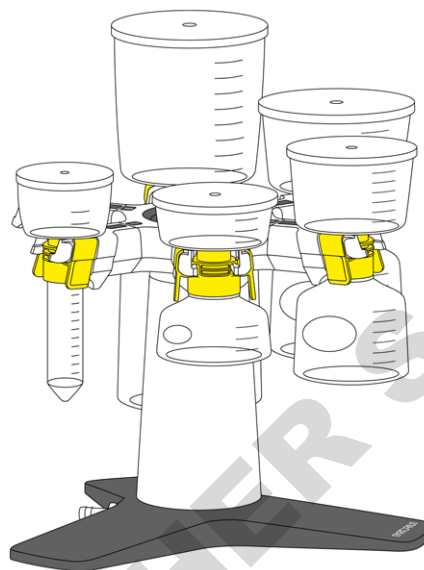

Sartolab® Bottle

Delivered sterile, for filtration and storage

Cat. No.	Description	Volume (mL)	Packing Unit
180-22-----E	Sartolab® bottle 150 mL	150	12
180-23-----E	Sartolab® bottle 250 mL	250	12
180-24-----E	Sartolab® bottle 500 mL	500	12
180-25-----E	Sartolab® bottle 1,000 mL	1,000	12



Binder-Free Glass Microfiber Prefilters

High purity prefilters to prevent the clogging of the membrane when filtering viscous or particulate-loaded solutions

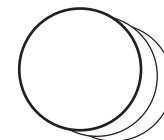

Cat. No.	Description	Filter Diameter (mm)	Packing Unit
FT-3-1101-080	Binder-free glass microfiber filter discs, grade MGA, for 150 and 250 mL funnels	80	100
FT-3-1101-100	Binder-free glass microfiber filter discs, grade MGA, for 500 and 1,000 mL funnels	100	100

Germany

Sartorius Lab Instruments
GmbH & Co. KG
Otto-Brenner-Strasse 20
37079 Goettingen
Phone +49 551 308 0

USA

Sartorius Corporation
565 Johnson Avenue
Bohemia, NY 11716
Phone +1 631 254 4249
Toll-free +1 800 635 2906

🌐 For further information, visit
www.sartorius.com

DOMINIQUE DUTSCHER SAS