PRIM

Light & Advanced

User's manual

Ref. 0NCIAU-B

DOMINIQUE DUTSCHER SAS

SUMMARY

1 REMARKS	5
2 WARRANTY	7
3 INFORMATION	9
4 PRECAUTIONS OF USE	11
5 INSTALLATION	13
5.1 INSTALLATION.....	13
5.2 FEATURE OF THE NETWORK	13
6 GÉNÉRAL INFORMATION	15
6.1 THE KEYBOARD	15
6.2 DEFINITION	15
6.3 LINE OF STATE.....	15
6.4 THE UPPER & LOWER NAVIGATOR KEYS	16
6.5 THE RIGHT & LEFT NAVIGATOR ARROWS.....	16
6.6 MEASURE OF THE ZERO	16
6.7 LIMITS OF CONCENTRATION.....	16
6.8 PRINTING THE RESULTS	16
6.9 STAND-BY MODE.....	17
6.10 FLAGS TO USERS.....	17
6.11 ERROR MESSAGES	17
6.12 AUTOTEST	17
6.13 FLOW CHART.....	18
7 AUTOTEST	19
7.1 DESCRIPTION	19
7.2 ACCESS TO THE AUTOTEST MODE.....	19
8 ABSORBANCE	21
8.1 ACCESS TO THE ABSORBANCE MODE	21
8.1.1 Upon starting up PRIM.....	21
8.1.2 From the main menu	21
8.2 KEY IN THE WAVELENGTH.....	21
8.3 MEASURE OF THE ZERO	21
8.4 MEASURE OF THE SAMPLE	22
8.5 PRINTING OF RESULTS	22
8.6 QUITTING THE MEASURING MODE.....	22
9 CONCENTRATION	23
9.1 KEY IN THE WAVELENGTH.....	23
9.2 KEY IN STANDARD OR FACTOR VALUE	23
9.3 MEASURE OF THE BLANK.....	24
9.4 MEASURE OF THE STANDARD	24
9.5 MEASURE OF SEVERAL STANDARDS.....	24
9.6 MEASURE OF THE SAMPLE	25
9.7 PRINTING OF RESULTS	25
9.8 QUITTING THE MODE	26

PRIM Light & Advanced

10 KINETICS	27
10.1 KEY IN THE WAVELENGTH	27
10.2 PROGRAMMING MEASURE TIME	27
10.2.1 Initial delay	27
10.2.2 Time of interval	28
10.2.3 Number of intervals	28
10.3 KEY IN FACTOR OR STANDARD	28
10.4 MEASURE OF THE BLANK	28
10.5 MEASURE OF THE STANDARD	28
10.6 MEASURE OF THE SAMPLE	29
10.7 PRINTING OF RESULT	29
10.8 QUITTING THE KINETICS MODE	30
11 MULTI WAVELENGTHS	31
11.1 KEY IN WAVELENGTH	31
11.2 MEASURE OF THE BLANK	32
11.3 MEASURE OF THE SAMPLE	32
11.4 PRINTING OF RESULTS	33
11.5 QUITTING THE MODE	33
12 TRANSMISSION	35
12.1 QUITTING THE MODE	35
13 SPECTRUM	37
13.1 OPERATION	37
13.1.1 Installation and operation	37
13.1.2 Spectrum scanning	37
13.1.3 Wavelengths selection	37
13.1.4 Baseline measurement	38
13.1.5 Sample measurement	38
13.1.6 Spectrum scanning print-out	39
13.1.7 Escape SPECTRUM mode	39
13.1.8 Storage	39
13.1.9 Remarks	39
14 METHODS	41
14.1 STORING A METHOD	41
14.2 LOADING A METHOD	42
14.3 ERASING A METHOD	42
15 CONFIGURATION	43
15.1 LANGUAGE	43
15.2 DATE	43
15.3 STAND-BY	43
16 RS 232 OUTPUT	45
16.1 CONNECTOR	45
16.2 DATA SIZE	45
16.3 PRINTERS	45
16.3.1 Printer dip switch settings	45

1 REMARKS

The Automatic aspiration system kit is manufactured by AQUALABO ANALYSE.

The information contained in this document may be the object of patents or patent applications by AQUALABO ANALYSE. The possession of this document does not confer any license to such patents.

The following names are AQUALABO ANALYSE's **registered trademarks** throughout the world.

SECOMAM
PRIM Light
PRIM Advanced

This manual is updated periodically. The updates are included in the new editions.

All information supplied in this edition of the manual may be amended before the products described herein are available.

All reproduction rights reserved.

DOMINIQUE DUTSCHER SAS

2 WARRANTY

The new equipment and material sold by AQUALABO ANALYSE is guaranteed against any manufacturing defects for one year (unless otherwise stated by AQUALABO ANALYSE) with effect:

- From the technical acceptance of the equipment in the factory by the buyer or his designee,
- or failing this :
 - * For Metropolitan France: from the date on the delivery note.
 - * For other destinations: from the date of factory shipment certified by air waybill, consignment note or bill of lading.

The AQUALABO ANALYSE company guarantee applies exclusively to defectiveness arising from a design fault or from a concealed defect. It is strictly limited to the free dispatching of replacement parts (except for consumable items) or to the repairing of the equipment in our workshops within a deadline of 10 working days (shipping delay not included).

By express agreement, the following are strictly excluded from our guarantee:

- All damages, notably for staff costs, loss of earnings, business trouble, etc
- Any breakdown due to an incorrect use of the equipment (non adapted mains, fall, attempt at transformation, etc) or to a lack of maintenance by the user or to poor storage conditions.
- Any breakdown due to the use of parts not supplied by AQUALABO ANALYSE, on AQUALABO ANALYSE equipment
- Any breakdown due to the transporting of the equipment in packaging which is not its original packaging
- The lamps, the cells and generally any item which appears in the "accessories" section on the price list.

Our customers are kindly asked to apply for our consent before returning any instrument for repair. No return of materials may be accepted without the prior written consent of our Servicing after Sales Management which will precise the terms of such return.

If the above consent is given, articles shall be returned in their original packaging on a prepaid basis to the following address:

AQUALABO ANALYSE Usine SECOMAM - 91 avenue des Pins d'Alep – 30100 ALES FRANCE

We reserve the right to reship all instruments received collect failing such consent.

Whatever method and conditions of transport are chosen for the shipment of the equipment to be repaired under guarantee, in the original packaging, the corresponding costs and the insurance costs will be payable by the customer.

Any damage connected to the return transport of the equipment falls within the framework of the guarantee on the express condition that the customer has sent his complaint within forty-eight hours by registered letter with acknowledgement of receipt to the carrier. A copy of the letter should be sent to AQUALABO ANALYSE.

For equipment with a guaranty card, this is only applicable if the card delivered with the equipment is returned to AQUALABO ANALYSE duly completed.

PRIM Light & Advanced

SOFTWARE GUARANTEE

The software is guaranteed by the designer or the distributor of the software under the conditions specified in the literature accompanying the aforementioned software packages. Under no circumstances whatsoever will AQUALABO ANALYSE supply any type of guarantee for software packages.

By express agreement, all damages, notably for staff costs, lost of earnings; business trouble, etc are strictly excluded from our guarantee.

The customer is informed that the software cannot be guaranteed exempt from defects or bugs.

TRADE SECRET AND PROPERTY RIGHTS

This document is protected by a AQUALABO ANALYSE copyright (c) 2003 and the copying rights are explicitly reserved. The software supplied with the equipment or referenced contains trade secrets and confidential information which are AQUALABO ANALYSE's property. It is legally protected by the international copyright (c) laws.

AQUALABO ANALYSE grants a license to use its software to the user. This may not be disclosed, used or duplicated with the intention to save it, without AQUALABO ANALYSE's written permission. The beneficiary must attach a copy of this document to all authorized partial or total reproductions.

3 INFORMATION

The AQUALABO ANALYSE equipment has been designed, manufactured, tested and inspected according to the ISO 9001 standards.

If the unit is not immediately installed, it should be stored in a dry and clean area. The storage temperature should be between 10 and 35°C.

AQUALABO ANALYSE equipment is carefully inspected before it is packed. As soon as you receive your equipment, check the condition of the packaging and if you notice any problems, notify your carrier within 48 hours. Then consult the packing list and check that everything is in order. Finally, if you discover that something is missing, or if the goods are damaged immediately notify AQUALABO ANALYSE.

DOMINIQUE DUTSCHER SAS

4 PRECAUTIONS OF USE



- Always make sure that the instrument is connected on the good voltage.
(Between 100 – 240V 50-60Hz)
- Always disconnect the mains plug before starting any work inside the instrument.
- When dangerous substances for health and environment are used, the laboratory or site rules, where the instrument is installed must be followed.
- Take all the necessary precautions, during the use the instrument, to protect the operator from eventual liquids leaks or spills or possible radiations (protective gloves, glasses , protected clothes, etc)
- All operations made inside the instrument, must be done by AQUALABO ANALYSE or by AQUALABO ANALYSE's authorized technicians.
- Use of the spectrophotometer without danger

If it is necessary to suppose that it is not possible any more to use the spectrophotometer without danger, it is necessary to put it out of service and to protect it from involuntary starting up again.

Use without danger will not be possible when the spectrophotometer

- suffered damage during transportation.
- was stored under inadequate conditions for one relatively long period
- present some visible damages.
- does not function any more as described in the user's manual.

In case of doubt, consult the spectrophotometer supplier.

DOMINIQUE DUTSCHER SAS

5 INSTALLATION

5.1 INSTALLATION

All precautions of rigidity and flatness of the support of the instrument must be taken so that the optic bench didn't undergo any distortion.

5.2 FEATURE OF THE NETWORK

It requires, for its load, of a transformer 110/240V / 12V AC, 25W 50-60 Hz (in accordance with the International Norm IEC-38 of 1983), of a less equal strength to 50 VA. The hold should be inevitably compliant to the existing norms and should equip of an earth.

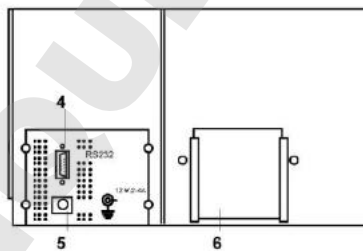
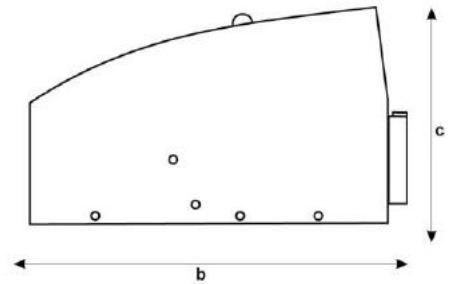
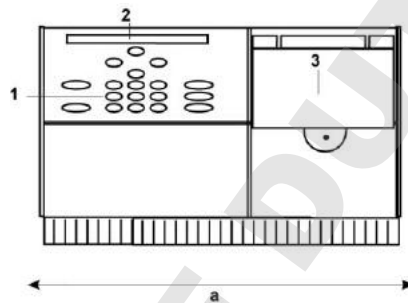

Dimensions :

a : 260 mm
b : 220 mm
c : 180 mm

Technical specifications

- 1- Keyboard
- 2- 2 lines LCD display
- 3- Sample holder door
- 4- RS232C serial interface
- 5- Power connection
- 6- Lamp cover

DOMINIQUE DUTSCHER SAS

6 GÉNÉRAL INFORMATION

This manual describes the specifications of Prim Light and Prim Advanced. Parts concerning Prim Advanced are indicated by " PRIM Advanced only! ".

6.1 THE KEYBOARD

The keyboard consists of the following keys:

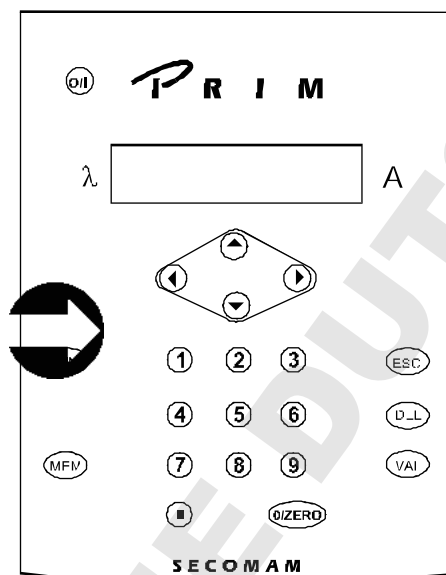

Numerical entries

- 1 keypad (numbered from 0 to 9 and the point ' . ').

Navigation menus

- 4 Navigator arrows - Right, Left & Upper, Lower.

On/Off of the PRIM

- 1 key " I / O "

Validation of entries

- 1 key " VAL "

Correction of entries

- 1 key " DEL "

Return to the main menu

- 1 key " ESC "

Safeguarding/access to methods

- 1 key " MEM "

Printing results

- 1 key " PRINT "

6.2 DEFINITION

Remarks are situated in the margin and are framed of way as follow :



Tips are situated in the margin and are preceded of the icon :



6.3 LINE OF STATE

The second line of the LCD indicates the wavelength and the Absorbance value permanently & in real time (line of status):

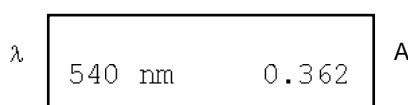

6.4 THE UPPER & LOWER NAVIGATOR KEYS

By using the Upper and Lower arrows, you can display different information according to the menu used. Thus you can :

- move from one mode of the vertical main line to another (see chapter 6.13), for example from Absorbance to Configuration.
- have access to an analysis by name when using **Method** menu.
- have the limits to choose displayed upon keying in a number.
- have the parameters of a method displayed when you are working within the menu **Safeguarding a method**.

6.5 THE RIGHT & LEFT NAVIGATOR ARROWS

To inform you that you are given several choices, two arrows appear on both sides of the display.

- use Right and Left Navigator Arrows to switch between different options proposed.
- use " VAL " to validate.
- use " ESC " to return to the main menu without considering the modification (in the main menu it allows you to return directly to the Absorbance mode).

Numerical keypad as well as " DEL " and " MEM " keys are not employed in menus except when naming an analysis for the purpose of safeguarding it.

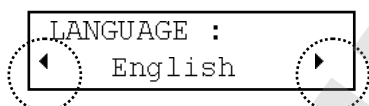

6.6 MEASURE OF THE ZERO

Within one measuring mode, when PRIM asks " BLANK READY ? ", you should reply by " VAL " to have your choice taken into account.

In any case, you keep the possibility to run the zero by pressing the " 0/ZERO "key.

6.7 LIMITS OF CONCENTRATION

One-standard and factor Mode: the concentration of a sample is only limited by PRIM absorbance limit. (2.500Abs)

Multi-standards Mode: the concentration of a sample should not exceed 10% the value of the last standard of the curve.

6.8 PRINTING THE RESULTS

Only numerical values are printed : method name, date and hour. A space is reserved for the user's signature or identification in accordance to the requirements of the Good Laboratory Practices.

It is not intended to print graphs.

PRIM Light & Advanced

6.9 STAND-BY MODE

The stand-by mode of PRIM can be programmed using the configuration menu. When PRIM is in stand-by mode, the hour and the date are displayed, the lamp and the back-light off. Use the ON/OFF (I/O) button to reactivate PRIM and have the normal display; the PRIM reruns its autotest and resets on Absorbance mode.

6.10 FLAGS TO USERS

LCD	Problems	LCD- Line 2
Blinking	The Absorbance is superior to 2,500. PRIM is not linear to all wavelength.	Blinking
Conc < 0	The value in concentration is negative.	-
> Lin	The value in concentration is beyond the linearity limit of the straight standard.	-
Memory empty !	No analysis is present in memory	-
Saturated memory	Insufficient space for the safeguard of a new analysis.	-
-	The printer doesn't answer.	« Retry? » or « Abandon? »

6.11 ERROR MESSAGES

LCD	Problems	LCD- Line 2
-	Lamp or sensor out of order	Lmp Pb
Memory problem	EEPROM no accessible : back-up or loading impossible	
Clock problem	No accessible clock, hour and date are not correct	
WL problem	PRIM WL doesn't set.	Retry or Abandon
Energy problem	The light beam is shifted from the cell axis.	Retry or Abandon
Black problem		Retry or Abandon

For any case other than the 1st case, call after-sales service.

6.12 AUTOTEST

During the autotest, PRIM displays the type of test in progress. None of the problems detected will block the PRIM. You have the choice to either pursue or restart the autotest.

Before starting the autotest, PRIM displays the type of PRIM (PRIM Light or PRIM Advanced), the software version, as well as the device serial number:

PRIM Advanced V1.0 - S/N 218

PRIM Light & Advanced

It is recommended to note this information down on the manual. It will be needed the day you call our authorized servicing network to report a problem.

6.13 FLOW CHART

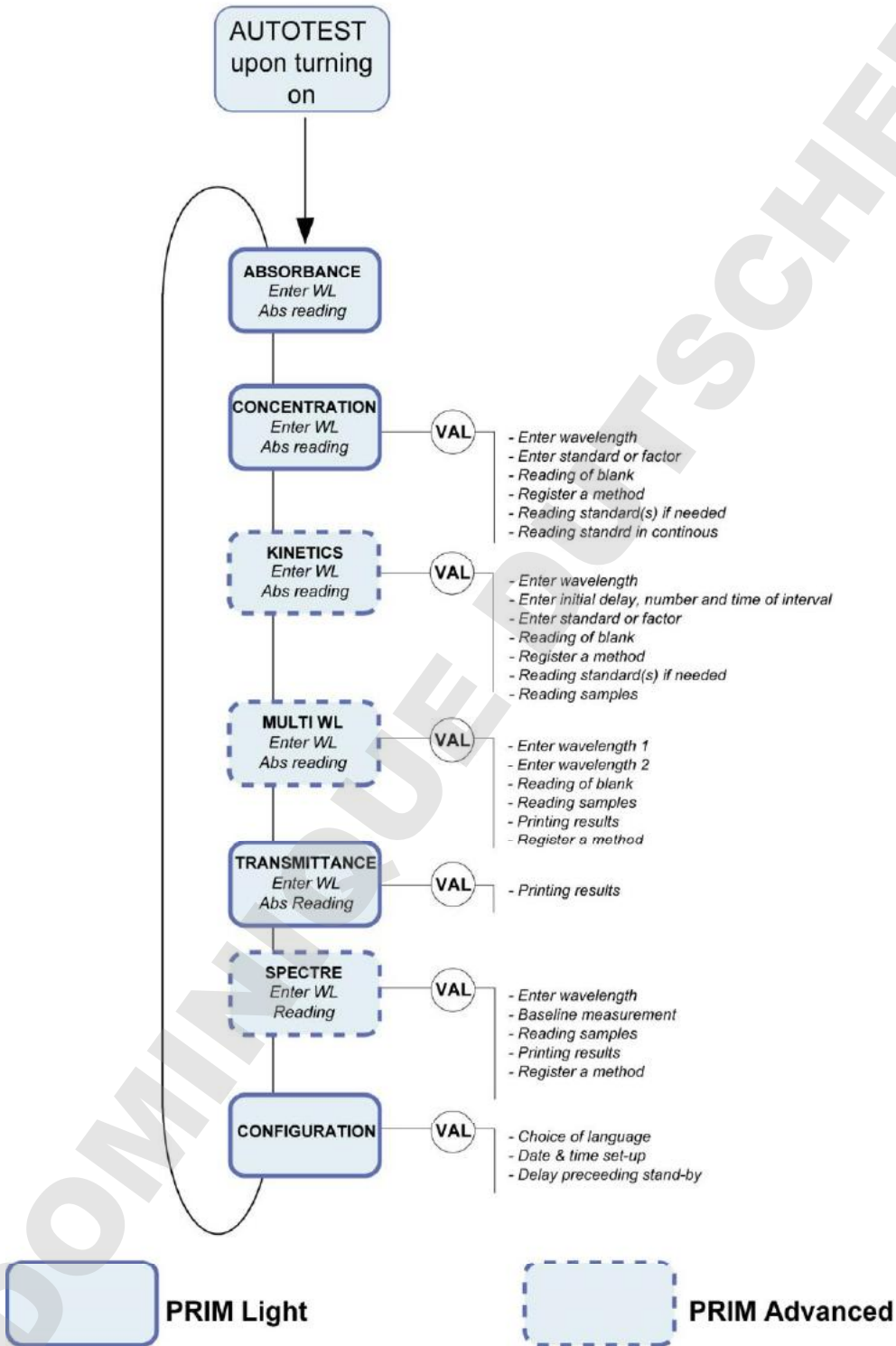

7 AUTOTEST

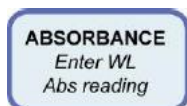

7.1 DESCRIPTION

Upon starting up the PRIM (I/O key), these are the successive stages of automatic test:

- Indication of PRIM model (Light or Advanced),
- Indication of the software version number,
- Indication of PRIM serial number,
- Wavelength recalibration,
- Filter-wheel positioning,
- Memory test,
- Internal clock test.

7.2 ACCESS TO THE AUTOTEST MODE

To go from the stand-by mode to the autotest mode simply press the “ I/O ” key (see chapter 6.9).

```
SECOMAM - PRIM light V1.0 - Nr 218
16/12/1997 - 17h38

User : .....

Starting Autotest
Test lamp      : Passed
Test EEPROM    : Passed
Test horloge   : Passed

Calibrage LO 441,9
Calibrage LO 476,2
Calibrage LO 528,7
Calibrage LO 584,4
Calibrage LO 684,7
Calibrage LO 744,2
Wavelength Test : Passed

Autotest : Passed
```

DOMINIQUE DUTSCHER SAS

8 ABSORBANCE

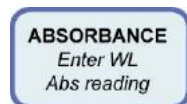

8.1 ACCESS TO THE ABSORBANCE MODE

```
ABSORBANCE
540 NM      0.213
```

The displayed values are always the latest used value arbitrarily

8.1.1 Upon starting up PRIM

After the autotest, the Absorbance mode is selected automatically.

8.1.2 From the main menu

From whatever position of the main menu, there are two ways to go back to the Absorbance mode:

- by using the Upper & Lower Navigator keys,
- by pressing the "ESC" key.

8.2 KEY IN THE WAVELENGTH

Modify the wavelength by entering a new value using the numerical keys. (This will interrupt the permanent display of value read), confirm the wavelength by "VAL "

```
Wavelength
3_ nm
```

PRIM sets and displays successively:

```
350 nm setting...
```

```
Absorbance
350 nm      0.312
```

The display indicates the values of the wavelength and the Absorbance in real time.

8.3 MEASURE OF THE ZERO

The zero (blank) is done by pressing the "0" key.

```
Absorbance
350 nm      0.000
```

PRIM Light & Advanced

8.4 MEASURE OF THE SAMPLE

Sample measure is done in continuous. Display indicates the mode, wavelength and Absorbance simultaneously.

8.5 PRINTING OF RESULTS

Printing of results is done by pressing "PRINT" key.

```
SECOMAM - PRIM light V1.0 - Nr 218
16/12/1997 - 5:10 pm

Utilisateur : .....
16/12/1997 - 5:10 pm
Mode : Absorbance
longueur d'onde : 540 nm

Ech : 01      0.213Abs    17h39
Ech : 02      0.832Abs    17h50
Ech : 03      1.352Abs    17h55
```

```
SECOMAM - PRIM light V1.0 - S/N 218
16/12/1997 - 5:10 pm

User : .....
16/12/1997 - 5:10 pm
Mode : Absorbance
Wavelength   : 540 nm

Sam. : 01      0.213Abs    5:39 pm
Sam. : 02      0.832Abs    5:50 pm
Sam. : 03      1.352Abs    5:50 pm
```

8.6 QUITTING THE MEASURING MODE

Use the Upper & Lower Navigator arrows to exit from the Absorbance mode and proceed to the next measuring mode .

9 CONCENTRATION

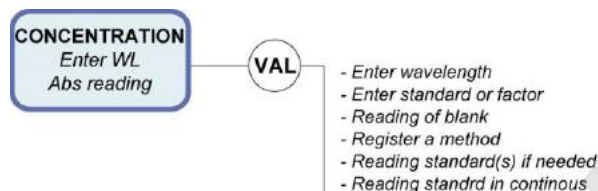

From the main menu, select Concentration mode with the help of Upper & Lower Navigator keys.

```
Concentration
540 nm      0.213
```

Validate the Concentration mode by ' VAL '.

```
Wavelength
540 nm      0.213
```

9.1 KEY IN THE WAVELENGTH

This step is no longer necessary in preprogrammed method.

Modify the wavelength by keying a new value directly using numerical keys. (this will interrupt the permanent display of value read), then " VAL ".

```
Wavelength
3_ nm
```

PRIM sets and displays successively:

```
◀ Facteur ▶
350 nm      0.312
```

9.2 KEY IN STANDARD OR FACTOR VALUE

This step is no longer necessary in preprogrammed method.

Select " Factor " or " n Standard " using the Right & Left Navigator keys.

PRIM Light $n = 1$
PRIM Advanced $n = 1$ to 8

Validate the choice by « VAL ».

```
Standard    Ready?
340 nm      0.000
```

- in the case of a Factor (maximal value 9999)

```
Facteur :   15.0
340 nm      0.312
```

- in the case of one Standard (maximal range 0.001 to 9999)

PRIM Light & Advanced

Etalon :	10.0
340 nm	0.312

- in the case of n Standards (0.001 to 9999)

Std 1:	10.0
340 nm	0.312

Validate or modify the proposed numerical value (last value used or calculated) by keying the new value using the numerical keys.

9.3 MEASURE OF THE BLANK

PRIM requests for the blank :

Blank	Ready?
340 nm	0.312

Insert the blank then validate by "VAL", PRIM does the zero, then proceeds to the next step.

9.4 MEASURE OF THE STANDARD

Insert the standard then validate, PRIM does the measure, and the display indicates the value of the calculated Factor as well as the concentration at 0 absorbance.

Factor :	15.3
340 nm	0.159

The calculation done is a linear regression non-obligatorily through zero.

Origin :	15.3
340 nm	0.159

Use "VAL" key to print the measured values and proceed with sample readings.

Use "DEL" key to measure a new standard.

At this stage, method can be stored (see chapter 14.2)

9.5 MEASURE OF SEVERAL STANDARDS

PRIM Advanced only !

The straight standard is of linear regression type. You have to program at least 2 standards to reach this menu.

Insert the standard indicated then validate,

Standard 1	Ready?
340 nm	0.000

PRIM Light & Advanced

PRIM runs the measure, displays the standard value. Validate to print the value and proceed to the next standard.

Repeat the operation until PRIM displays the value of the calculated factor from the straight regression. Use the Right & Left Navigator arrows to display the ordinate at the origin of the standard curve.

```
◀ Origin : 0.025 ▶  
340 nm      0.159
```

```
◀ Factor : 15.3 ▶  
340 nm      0.159
```

Use "VAL" key to print the measured values and proceed with sample readings.

Use "DEL" key to measure a new standard.

At this stage, method can be stored (see chapter 14.2)

9.6 MEASURE OF THE SAMPLE

Insert sample of unknown concentration.

```
Sam :      0.0  
340 nm     0.000
```

PRIM runs the measure in continuous, upper display indicates the value of the sample in Concentration.

```
Sam :      13.2  
340 nm     0.212
```

In the case of a multi-standard concentration, values of samples beyond more than 10% to that of the last standard of the range are not accepted, the display indicates "> Lin". Negative values of concentration are not accepted, the display indicates "Conc < 0".

9.7 PRINTING OF RESULTS

Use the "VAL" key to print the value of the sample and adding the number of the sample.

```
Sam 2 :     13.2  
340 nm     0.212
```

Use the "PRINT" key to print the sample without adding the number of the sample (it allows to attempt another printing instruction if the software is set-up without printer.)

Example of printed results :
in the case of a factor:

```
SECOMAM - PRIM light V1.0 - Nr 218  
16/12/1997 - 5:10 pm  
  
User : .....  
16/12/1997 - 5:10 pm  
Mode           : Concentration  
wavelength     : 540 nm  
Factor         : 13.6  
  
Sam : 001      2.9      0.213Abs  
Sam : 002     11.3     0.832Abs  
Sam : 003     18.4     1.352Abs
```

in the case of a standard:

```
SECOMAM - PRIM light V1.0 - Nr 218  
16/12/1997 - 5:10 pm  
  
User : .....  
16/12/1997 - 5:10 pm  
Mode           : Concentration  
wavelength     : 540 nm  
No.Std        : 1  
Factor         : 16.7  
  
Std           13.6      0.812Abs  
  
Sam : 001      2.9      0.213Abs  
Sam : 002     11.3     0.832Abs
```

PRIM Light & Advanced

in the case of several standards:

PRIM Advanced only !

```
SECOMAM - PRIM Advanced V1.0 - Nr 218
16/12/1997 - 5:10 pm

User : .....
16/12/1997 - 5:10 pm
Mode          : Concentration
wavelength    : 540 nm
No. Std       : 4
Origin        : 0.025
Correlation    : 0.717
Factor        : 16.7

Std 1         10.0      0.212Abs
Std 2         20.0      0.325Abs
Std 3         40.0      0.421Abs
Std 4         80.0      0.519Abs

Sam : 01      2.9      0.213Abs
Sam : 02     11.3      0.832Abs
```

9.8 QUITTING THE MODE

Use the "ESC" key to quit the "Concentration" mode and to return to the main menu.

10 KINETICS

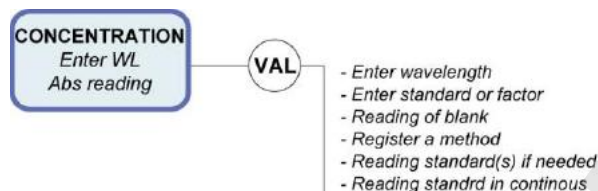

PRIM Advanced only !

From the main menu, select the KINETICS mode with the help of the Upper & Lower Navigator keys.

```
Kinetics
540 nm    0.213
```

Validate the KINETICS mode by "VAL".

```
Wavelength
540 nm    0.213
```

10.1 KEY IN THE WAVELENGTH

Modify the wavelength by keying a new value directly with the help of numerical keys (this will interrupt the permanent display of value read), then "VAL".

```
Wavelength
3_ nm
```

PRIM sets and displays successively :

```
350 nm Setting...
```

```
Init delay. : 20
350 nm     0.312
```

The display indicates the value of the wavelength and the Absorbance in real time.

10.2 PROGRAMMING MEASURE TIME

10.2.1 Initial delay

Limit : 0 to 240 seconds

```
Init. delay. : 20
350 nm     0.312
```

Validate or modify the proposed numerical value (which is the latest value used) using the numerical keys, by entering the new value directly.

This step is no longer necessary in preprogrammed method.



The limits of a value can be displayed at once by pressing Upper or Lower Navigator keys!

PRIM Light & Advanced

10.2.2 Time of interval

Limits : 1 to 240 seconds.

Tp inter. : 6
350 nm 0.312

Validate or modify the proposed numerical value (which is the latest value used) using the numerical keys, by entering the new value directly.

This step is no longer necessary in preprogrammed method.

10.2.3 Number of intervals

Limits : 1 to 25 intervals.

Number : 5
350 nm 0.312

Validate or modify the proposed numerical value (which is the latest value used) using the numerical keys, by entering the new value directly.

10.3 KEY IN FACTOR OR STANDARD

Use factor to calculate enzymatic activity. By default it is equal to 1.

Use standard to run KINETICS on a standard. The OD/min is calculated, then the corresponding factor is memorized.

Select "Factor" or "Standard" by using the Right & Left arrows.

◀ Factor ▶
340 nm 0.312

◀ Standard ▶
340 nm 0.312

Validate the choice by "VAL".

- in the case of a Factor (9999 Max.)

Factor : 15.0
340 nm 0.312

- in the case of one standard

Standard : 10.0
340 nm 0.312

10.4 MEASURE OF THE BLANK

Blank Ready?
340 NM 0.312

Insert the blank then validate, PRIM does the zero, proceeds to the next stage then:
At this stage, method can be stored (see chapter 14.2)

10.5 MEASURE OF THE STANDARD

Standard Ready?
340 nm 0.000

Insert the standard then validate, PRIM does the measure, and the display indicates the value of the calculated Factor.

PRIM Light & Advanced

Once the total time of KINETICS has elapsed, the display indicates the activity as well as the slope in OD/minute.

Use Right/ Left Navigator Arrows to display the standard slope.

```
Standard : 10.0
◀Pente 0.310/mn▶
```

```
Standard : 10.0
◀Factor: 15.3▶
```

Validate and print the value using ' VAL '.

Intermediate slope values in OD/min can be displayed using the Right/Left arrows.

```
Standard : 10.0
◀P01 0.305/mn▶
```

Use VAL key to print the measured values and proceed to sample readings.

Use DEL key to re-measure the standard.

At this stage, method can be stored (see chapter 14.2)

10.6 MEASURE OF THE SAMPLE

```
Sam Ready?
340 nm 0.000
```

Insert the sample and launch the KINETICS using ' VAL 'key

```
Delay : 0'27"
340 nm 0.123
```

The initial delay is indicated and time count down started. Absorbance value is displayed in continuous.

Once the initial delay has elapsed, display indicates time count down for KINETICS. The absorbance value is displayed in continuous.

```
Sam 1 : 1'03"
340 nm 0.513
```

Once the total time of KINETICS has elapsed, display indicates the activity as well as the slope in OD/minute.

Intermediate slope values in OD/min can be displayed using the Right Navigator key.

```
Sam 1 : 4.65
Pente 0.310/mn▶
```

```
Sam 1 : 4.65
◀P1 0.305/mn▶
```

Use " VAL " key to launch a new KINETICS without modifying the parameters.

10.7 PRINTING OF RESULT

Printing of results takes place:

- automatically at the end of the KINETICS.
- manually by pressing on " PRINT ".

Example of printed result:

PRIM Light & Advanced

```
SECOMAM - PRIM Advanced V1.0 - Nr 218  
16/12/1997 - 5:10 pm
```

```
Utilisateur : .....  
16/12/1997 - 5:10 pm  
Mode : Cinétique  
longueur d'onde : 540 nm  
Délai initial : 30 secondes  
Nombre intervalle : 4  
Temps intervalle : 25 secondes  
Facteur : 13.6
```

```
Ech 01 :  
T0 - 0.210Abs  
T1 - 0.230Abs  
T2 - 0.250Abs P1 = 0.306/minute  
T3 - 0.270Abs P2 = 0.307/minute  
T4 - 0.300Abs P3 = 0.309/minute
```

```
Activité : 4.161 Pente = 0.306/minute
```

```
Ech 02 :  
T0 - 0.317Abs  
T1 - 0.335Abs  
T2 - 0.355Abs P1 = 0.016/minute  
T3 - 0.370Abs P2 = 0.017/minute  
T4 - 0.400Abs P3 = 0.019/minute
```

```
Ech : 002 11.3 0.832A  
Ech : 003 18.4 1.352A
```

10.8 QUITTING THE KINETICS MODE

Use "ESC" to leave the ' KINETICS ' mode and return to the main menu.

11 MULTI WAVELENGTHS

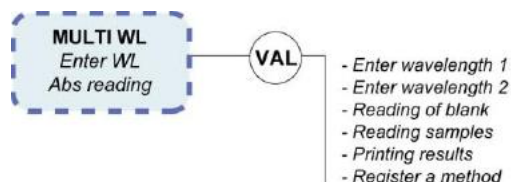

PRIM Advanced only !

From the main menu, select Multi WL mode using the Upper & Lower Navigator keys.

```
Wavelength 1
540 nm      0.213
```

Validate the Multi WL mode using ' « VAL ».

```
Wavelength 1
540 nm      0.213
```

This step is no longer necessary in preprogrammed method.

11.1 KEY IN WAVELENGTH

Modify wavelength 1 by entering a new value directly using the numerical keys. (This will interrupt the permanent display of the value read), confirm by " VAL ".

```
Wavelength 1
3_ nm
```

Repeat the above operations to enter the 2nd wavelength (550 nm). PRIM sets and displays successively:

```
550 nm Setting...   Blank   Ready?
                    550 nm   0.312
```

11.2 MEASURE OF THE BLANK

Insert the blank then validate, PRIM does the zero on the 2 wavelengths

```
Blank
550 nm Setting...
```

```
Blank
550 nm      0.000
```

```
Blank
340 nm Setting...
```

```
Blank
340 nm      0.000
```

then displays :

```
Sam      Ready?
340 nm    0.000
```

At this stage, method can be stored (see chapter 14.2)

11.3 MEASURE OF THE SAMPLE

Insert the sample and then validate, PRIM does the measure on the 2 wavelengths.

```
Sam
550 nm Setting...
```

```
Sam
550 nm      1.250
```

```
Sam
340 nm Setting...
```

```
Sam
340 nm      1.567
```

then displays results in ratio and difference of absorbance (delta):

```
◀ L01/L02 : 1.254 ▶   ▶ 550 nm  1.250 ▶
◀ L01-L02 : 0.317 ▶   ▶ 340 nm  1.567 ▶
```

Values of absorbances of the two respective wavelengths can be displayed using the Right Navigator key.

Use ' VAL ' key to launch a new measure without modifying parameters.

11.4 PRINTING OF RESULTS

Printing of results takes place:

- automatically at the end of the measure.
- manually by pressing "PRINT".

```
SECOMAM - PRIM Advanced V1.0 - Nr 218
16/12/1997 - 5:10 pm

User : .....
16/12/1997 - 5:10 pm
Mode      : Multi wavelength
Wavelength 1 : 540 nm
Wavelength 2 : 610 nm

Sam 01
LO1/LO2 = 0.104      LO1-LO2= -1.090
  WL1 : 0.127Abs
  WL2 : 1.217Abs

Sam 02
LO1/LO2 = 0.284      LO1-LO2 = -0.691
  WL1 : 0.274Abs
  WL2 : 0.965Abs
```

11.5 QUITTING THE MODE

Use "ESC" key to quit the "Multi WL" mode and to return to the main menu.

DOMINIQUE DUTSCHER SAS

12 TRANSMITTANCE

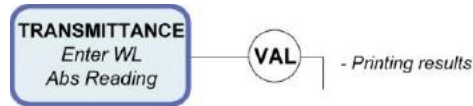

From the main menu, select Transmittance mode using Upper & Lower Navigator keys.

```
Trans. : 88.0%T
540 nm 0.213
```

Printing of results takes place by pressing "PRINT".
Example of printed results :

```
SECOMAM - PRIM Advanced V1.0 - Nr 218
16/12/1997 - 5:10 pm

User : .....
16/12/1997 - 5:10 pm
Mode      : Transmittance
Wavelength : 540 nm

Sam : 001      87.0%T      0.213Abs
Sam : 002      23.5%T      0.832Abs
Sam : 003      17.9%T      1.352Abs
```

12.1 QUITTING THE MODE

Use "ESC" key to leave the "Transmittance" mode and to return to the main menu.

DOMINIQUE DUTSCHER SAS

13 SPECTRUM

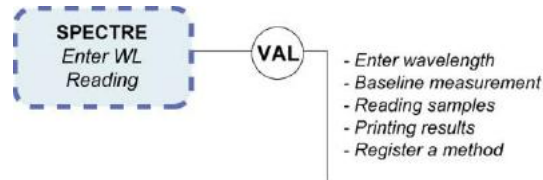

Special version PRIM SCAN, offers access to spectrum scanning in addition to all existing standard methods available in the PRIM Advanced. Spectrum scanning prints-out are only compatible with the CITIZEN IDP562RS or KYOLINE graphic printers (this one can be purchased from AQUALABO ANALYSE).

13.1 OPERATION

13.1.1 Installation and operation

When turning on the PRIM, screen displays "PRIM ADVANCED" along with the internal EEPROM version.

13.1.2 Spectrum scanning

```
SPECTRUM
540 nm      0.213
```

From main menu, select SPECTRUM mode with up & down Navigator keys.

```
Wavelength 1
540 nm      0.213
```

Validate Spectrum mode by pressing 'VAL', following screen appears :

13.1.3 Wavelengths selection

Note : This step is suppressed when a programmed method is recalled.

Select wavelength 1 directly on the numerical keyboard (wavelength selection stops real-time absorbance reading), then press 'VAL'

```
Wavelength 1
330 nm
```

Repeat previous action for wavelength 2 selection :

```
Wavelength 2
900 nm
```

Instrument will adjust the wavelengths, print headlines then displays :

Warning ! Wavelength 1 should be lower than wavelength 2.

PRIM Light & Advanced

Blank	Ready ?
400 nm	0.312

13.1.4 Baseline measurement

Before any spectrum scanning measurement, the PRIM needs to store all blank values from the selected wavelength range. These values are then subtracted from measured values on the sample. This blank storage is called baseline.

In order to perform baseline, insert blank sample then validate; instrument performs baseline between the 2 selected wavelengths :

Baseline	Zero...
----------	---------

Once baseline is stored, following screen is displayed :

Samp 1	Ready ?
330 nm	0.000

13.1.5 Sample measurement

Insert sample N°1 then validate by pressing 'VAL', following screens are displayed :

Sampl 1	Setting...
---------	------------

Sampl 1

PRIM measures all sample absorbance values in the selected wavelengths and automatically subtracts baseline values.

Once spectrum acquisition is over, PRIM asks if peaks and valleys values print-out is desired by displaying the following screen :

PEAKS / VALLEYS
Yes

Select "YES" by left and right Navigator keys then PRIM calculates peaks and valleys values (absorbance maximum and minimum). This calculation can last few seconds depending on the number of values. Once calculation is performed, peaks and valleys print-out is automatic and following screen appears :

Sampl 1	Printing...
---------	-------------

After printing, PRIM is ready to perform a new measurement on another sample and following screen is displayed :

Sampl 2	Ready ?
330 nm	0.000

'VAL' key runs another spectrum scanning with same baseline and same wavelength range as for sample N°1. In order to run a new baseline or to change wavelength range, escape spectrum mode by pressing "ESC" key and enter new parameters.

13.1.6 Spectrum scanning print-out

Spectrum values are directed automatically to the external printer along with peaks and valleys calculation.

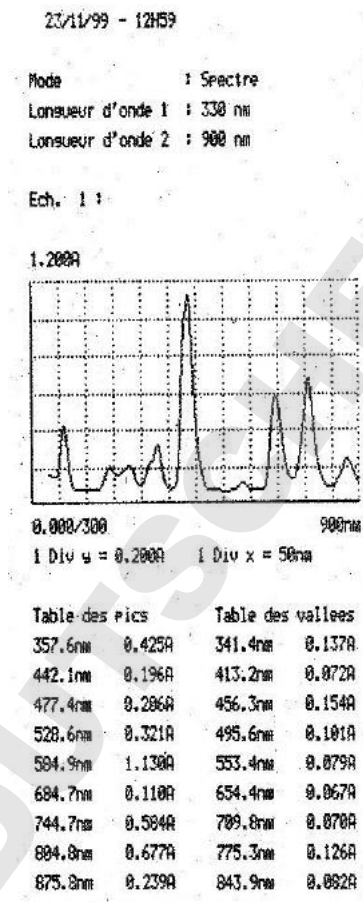

13.1.7 Escape SPECTRUM mode

To escape SPECTRUM mode and return to the main menu, press "ESC" key.

13.1.8 Storage

Spectrum method storage is the same as standard method storage described in the general user manual. Please refer to this manual for further information.

13.1.9 Remarks

Detection limit for peaks and valleys

Limit is 10 mAbs (0.010 Abs). To be detected in the peaks/valleys table, absorbance variation should be greater than 10 mAbs.

Graphic limits

For better readability, lower and upper limits of the wavelengths axis are ending by 0. For instance, if selected wavelength range is from 456 to 781 nm, print-out will be from 450 to 790 nm.

X and Y step values

To make readings easier, X and Y axis steps are printed under the graphic curve.

Automatic scaling

Automatic graphic scaling is performed. It is then possible to zoom any interesting part of the graphic curve. Peaks and valleys prints-out are the one corresponding to the zoomed portion.

PRIM Light & Advanced

Peaks and valleys limit

For a better readability, total peaks or valleys number is limited to 20 peaks and 20 valleys. If sample has more peaks and valleys than this limit, please perform scanning in separate parts.

DOMINIQUE DUTSCHER SAS

14 METHODS

The menu ' Methods ' appears only if at least one method has been saved.

From the main menu, select " Methods " mode using the " MEM " key.

Name : AMYLASE Kinetics		
7/50 Méthods ◀ ACID P. 2 ▶	7/50 Méthods ◀ AMYLASE 3 ▶	7/50 Methods ◀ ASAT/GOT 4 ▶
WL = 540 nm Factor : 12.3		
Intervalles = 4 Tp inter = 30sec		
Delay = 30sec		



All parameters of the method displayed can be seen by pressing the Upper & Lower arrows.

The upper line indicates how many methods are in file / out of 50 which the file can contain. The lower line indicates the method name as well as its file number. Methods are classified in alphabetical order.

Select the method you want using the Right & Left arrows.

14.1 STORING A METHOD

Use " MEM " key to save a method. This key takes the function Protects solely in the following cases:

If one or several memories remain free.

If, in KINETICS mode, the initial delay, the number of interval, the time of interval are already determined.

If, in Concentration mode, the type of calculation is already specified (Standard or Factor) as well as the value of the Factor (concentration AND Absorbance of standard(s)).

Then PRIM requests you to enter the name of the method (using 8 letters max.).

At first, the name is composed of 8 blanks by default or the pre-registered method.

- Use " Right " and " Left " Arrows to modify the letter.
- Use " ESC " during operation to quit the menu without protecting and return to the main menu
- Use " VAL " to validate a letter.
- Use " DEL " to modify the previous letter.

Name : ALBUM
◀ HIJKL -M- NOPQ ▶

If the name of the method already exists, the software asks for confirmation before deleting the previous method (the choice is by default " NO " *).

```
Erase ALBUMINE
◀      NON      ▶
```

14.2 LOADING A METHOD

To load the selected test just validate by « VAL ».

```
7/50 Methods ▾
◀ ACID P. 2 ▶
```

Test parameters are printed automatically. The software sets itself in the selected mode, ready to do a measure.

Upon next access to methods, the software would be set on the last method loaded.

14.3 ERASING A METHOD

To erase the pre-selected analysis simply validate « SUP ».

```
7/50 Methods ▾
◀ ACID P. 2 ▶
```

For every suppression of predefined method, the software requests confirmation (the choice is by default « NO »).

```
Erase ACID P.
◀      NO      ▶
```

15 CONFIGURATION

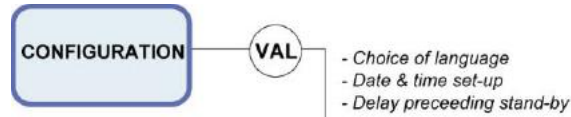

From the main menu, select the ' Configuration ' mode using the Upper & Lower Navigator keys.

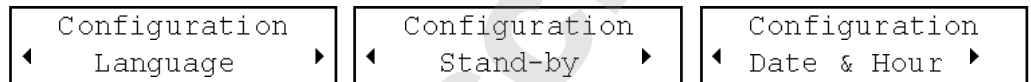

Select the option you want using the Right & Left Arrows, then " VAL ".

15.1 LANGUAGE

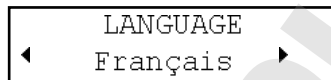

Select the option you want among French, English and Deutsch using the Right & Left arrows, then " VAL ".

15.2 DATE

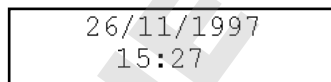

Modify values by pressing « SUP » key or by entering the new value of the day directly. Validate parameters by " VAL ".

15.3 STAND-BY

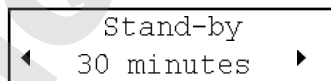

Select among the options 15, 30, 60 minutes and No using the Right & Left Navigator keys, then ' VAL '.

DOMINIQUE DUTSCHER SAS

16 RS 232 OUTPUT

16.1 CONNECTOR

Male connector 9 pins

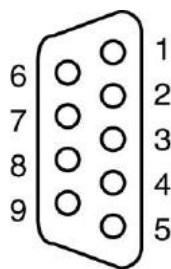

- 5- MASS
- 3- TXD PRIM TOWARDS PRINTERS.
- 2- CTS TERMINAL TOWARDS PRIM

16.2 DATA SIZE

1 START BIT - 8 S BITS - 1 STOP BIT – NO PARITY
CR = CR +LF (Slide return = slide return + advance paper).

16.3 PRINTERS

The compatible serial printers with PRIM are :
- KYOLINE, CITIZEN, EPSON, IBM (and compatibles).

16.3.1 Printer dip switch settings

Before installation, set the position of the 10 dip switches located under the printer in the following way :

1	ON	4	OFF	7	ON
2	OFF	5	OFF	8	OFF
3	OFF	6	OFF	9	OFF

OFF : Switch is down
ON : Switch is up (see diag.1).

If dip-switch position is not set as specified, spectrum scanning could be corrupted and not corresponding anymore to reality.

For any question, please contact your distributor.

PRIM Light & Advanced

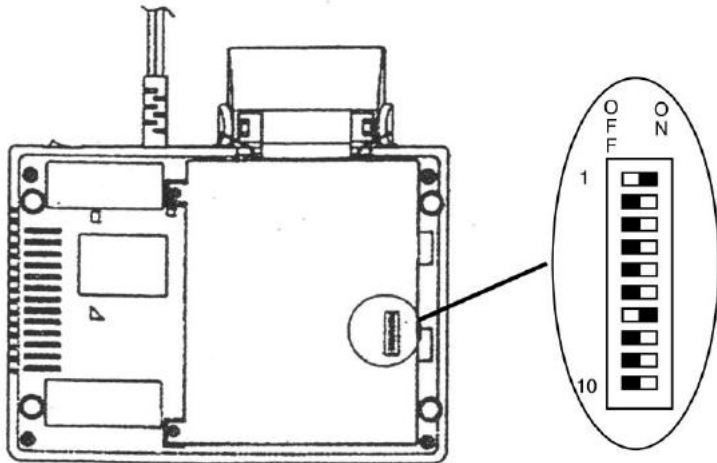

Note : Correct scan print-out is not guaranteed by AQUALABO ANALYSE if any other printer than the one recommended is used. Test should be conducted to confirm compatibility.

DOMINIQUE DUTSCHER SAS

Pour plus d'information, rendez-vous sur www.secomam.fr

For more information, go to www.secomam.fr



AQUALABO ANALYSE
SECOMAM

91 Avenue Des Pins D'Alep
30100 ALES
France

Tel : +33 (0)4 66 54 26 95
Fax : +33 (0)9 72 35 16 80
E-mail : info.secomam@aqualabo.fr
Web : www.secomam.fr

© 2015 AQUALABO-GROUP - All rights reserved

AQUALABO GROUP

13 bis Avenue des Aulnes
78250 Meulan-en-Yvelines
France

Tel : +33 (0)1 30 91 23 60
Fax : +33 (0)1 30 91 23 61
E-mail : info@aqualabo.fr
Web : www.aqualabo-group.com