



**EC Type-Approval Certificate
UK 2940**

Issued by:

**National Measurement Office
Notified Body Number 0126**

In accordance with the requirements of the Non-Automatic Weighing Instruments Regulations 2000 (SI 2000/3236) which implement, in the United Kingdom, Council Directive 2009/23/EC, this EC Type-Approval Certificate has been issued to:

**A&D Instruments Ltd
24 Blacklands Way
Abingdon Business Park
Abingdon
Oxfordshire OX14 1DY
United Kingdom**

in respect of a Class III, Non-Automatic Weighing Instrument designated the A&D SC-SE series and having the following characteristics:

Type	SC-30KAM SC-30KBM SE-30KAM SE-30KBM	SC-60KAM SC-60KAL SE-60KAM SE-60KAL	SC-60KBM SC-60KBL SE-60KBM SE-60KBL	SC-150KAM SC-150KAL SE-150KAM SE-150KAL	SC-150KBM SC-150KBL SE-150KBM SE-150KBL
Class	III				
Max	30 kg	60 kg		150 kg	
Min	200 g	400 g		1 kg	
e	10 g	20 g		50 g	
n	3000				

The necessary data (principal characteristics, alterations, securing, functioning etc) for identification purposes and conditions (when applicable) are set out in the descriptive annex to this certificate.

**Issue Date: 21 December 2012
Valid Until: 20 December 2022
Reference No: TS1201/0053**

**Signatory: G Stones
for Chief Executive**



0135



**National
Measurement
Office**

Descriptive Annex

1 INTRODUCTION

The A&D SC-SE series of instruments are battery powered, Class III Non-Automatic Weighing Instruments, fitted with a combined semi-automatic zero setting and subtractive tare balancing device, and a semi-automatic calibration and gravity compensation device.

2 DESCRIPTION

2.1 Construction

2.1.1 Mechanical

Main features:

- Base unit supporting the load cell and sensor unit. The indicator which incorporates the seven segment LCD display and the main board is mounted on a pole.
- Keypad consisting of five function keys.
- Six D type (LR20/R20P) batteries providing power to the weighing instrument.
- Load cell

2.1.2 Load Cell

The manufacturer of the load cells is A&D Scales Co.,Ltd, having the following models and capacities:

Model	Capacity (kg)
1LC176-30K	30
1LC176-60K	60
1LC176-150K	150

2.1.3 Keyboard

The keyboard consists of five functional keys (see Figure 3):

- ON/OFF - switches the display on and off.
- ZERO - sets the display to zero.
- PRINT- Outputs the weight value to a printer.
- UNITS- Switches the weighing value.
- TARE- Subtracts the tare (container) weight placed on the weighing pan.

2.1.4 Display

The LCD display consists of five 2.5 cm high, seven segment fields to display the weight value, and an additional field to display the units.

Up to four enunciators can be displayed, to indicate stable, polarity, net or zero. The STABLE indicator indicates when the reading is stable. The NET indicator indicates when NET weight is displayed when the tare function is used. The ZERO indicator indicates when the scale zero is correct. The polarity indicator indicates that the reading is negative when illuminated and positive when not illuminated.

2.1.5 Circuitry

All signal processing and communications with the load cell are achieved from the control circuitry within the main unit.

2.2 Operation

2.2.1 Switch on

On power up the instrument displays all segments for a few seconds and the 0 will be displayed.

2.2.2 Automatic power-off function

If the unit is left on and the stable indicator is displayed, an automatic power-off function turns the power off after approximately five minutes. To disable this function the ON/OFF key must be pressed at the same time as the TARE key. P1.10 will be displayed. Release both keys and the scale returns to the weighing mode.

2.2.3 Initial zero setting

Initial zero setting is possible between $\pm 16\%$ of max capacity.

2.2.4 Zero tracking

Zero tracking operates between $\pm 4\%$ of maximum capacity. The maximum speed of tracking is 0.5 d per second.

2.2.5 ZERO switch will zero the scale if the weight value is within 4% of the weighing capacity around the power-on zero point.

TARE switch will tare the scale and subtract the weight to zero as a tare weight when the weight is a plus value. In this case the zero ◀ and net ◀ indicators are on.

2.2.6 Semi-automatic calibration and gravity compensation device

In calibration mode the instrument may be calibrated using a weight or by entering a local gravity value.

2.2.7 Over range

Loads greater than nine divisions above maximum capacity result in an error code shown as 'E' in the centre of the weight display. The stability enunciator is blanked for unstable loads.

3 TECHNICAL DATA

3.1 The instrument is powered by six D type batteries (LR20/R20P).

4 PERIPHERAL DEVICES AND INTERFACES

4.1 Interfaces

The instrument may have the following interface type:

- USB interface
- Serial data interface RS232C

4.2 Peripheral devices

The following peripheral devices may be connected to the interfaces provided:

- Peripheral devices that have been issued with a test certificate by a Notified Body responsible for type approval under Directive 2009/23/EC; or
- Peripheral devices without a test certificate under the following conditions:
 - it bears the CE marking for conformity to the EMC Directive;
 - it is not capable of transmitting any data or instruction into the weighing instrument, other than to release a printout, checking for correct data transmission or validation;
 - it prints weighing results and other data as received from the weighing instrument without any modification or further processing;
 - it complies with the applicable requirements of EN45501, i.e. 4.2, 4.4, 4.6 and 4.7.

A printing device may print additional information such as date or number to identify the printed weighing result(s) or sets of weighing results.

5 SOFTWARE

The scale configuration and calibration parameters are stored in the EEPROM. The display indicates the software version number by, when power is off, press and hold TARE key and press POWER key. Release both keys to display software version. The software version will be in the format of "P1.10".

6 APPROVAL CONDITIONS

This certificate is issued subject to the following conditions:

6.1 Legends and inscriptions

6.1.1 The instrument bears the following legends (see Figure 3):

Max
Min
e =

6.1.2 The instrument shall bear the following legends:

CE mark
Verification mark
Green M
Class
Serial number
Manufacturers mark or name
Certificate number

The markings and inscriptions shall fulfil the requirements of Paragraph 1 of Annex IV of the Directive 2009/23/EC.

6.1.3 The SC-SE series of instruments are not to be used for direct sales to the public.

7 LOCATION OF SEALS AND VERIFICATION MARKS

The rating plate is secured, either by sealing or by being of a form such that it is destroyed when removed.

The data plate (see Figure 4), green M sticker and the verification mark are mounted on the top of the instrument.

A wire and lead seal sealing the two entry ports on the bottom of the instrument prevent access to the load cell, main circuit board and calibration lock switch. (see Figure 5).

The wire and lead seal may have the mark of a verification officer, or alternatively, the manufacturers mark.

8 AUTHORISED ALTERNATIVES

There are no authorised alternatives

9 ILLUSTRATIONS

- Figure 1 SE Series
- Figure 2 SC Series
- Figure 3 Display & legends
- Figure 4 Data plate
- Figure 5 Sealing diagram

10 CERTIFICATE HISTORY

Issue No.	Date	Description
UK 2940	20 December 2012	Type approval first issued

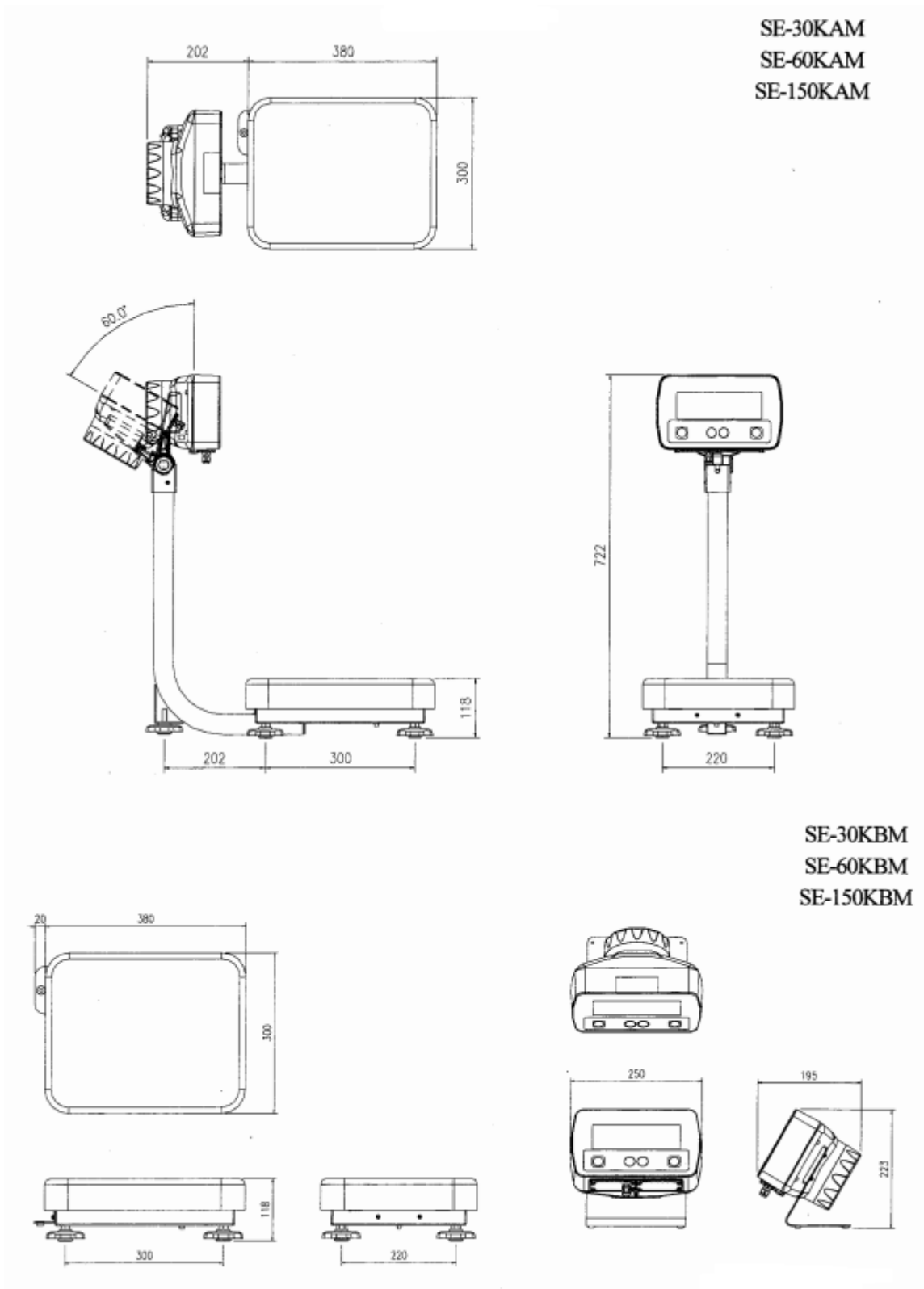

Figure 1 SE Series

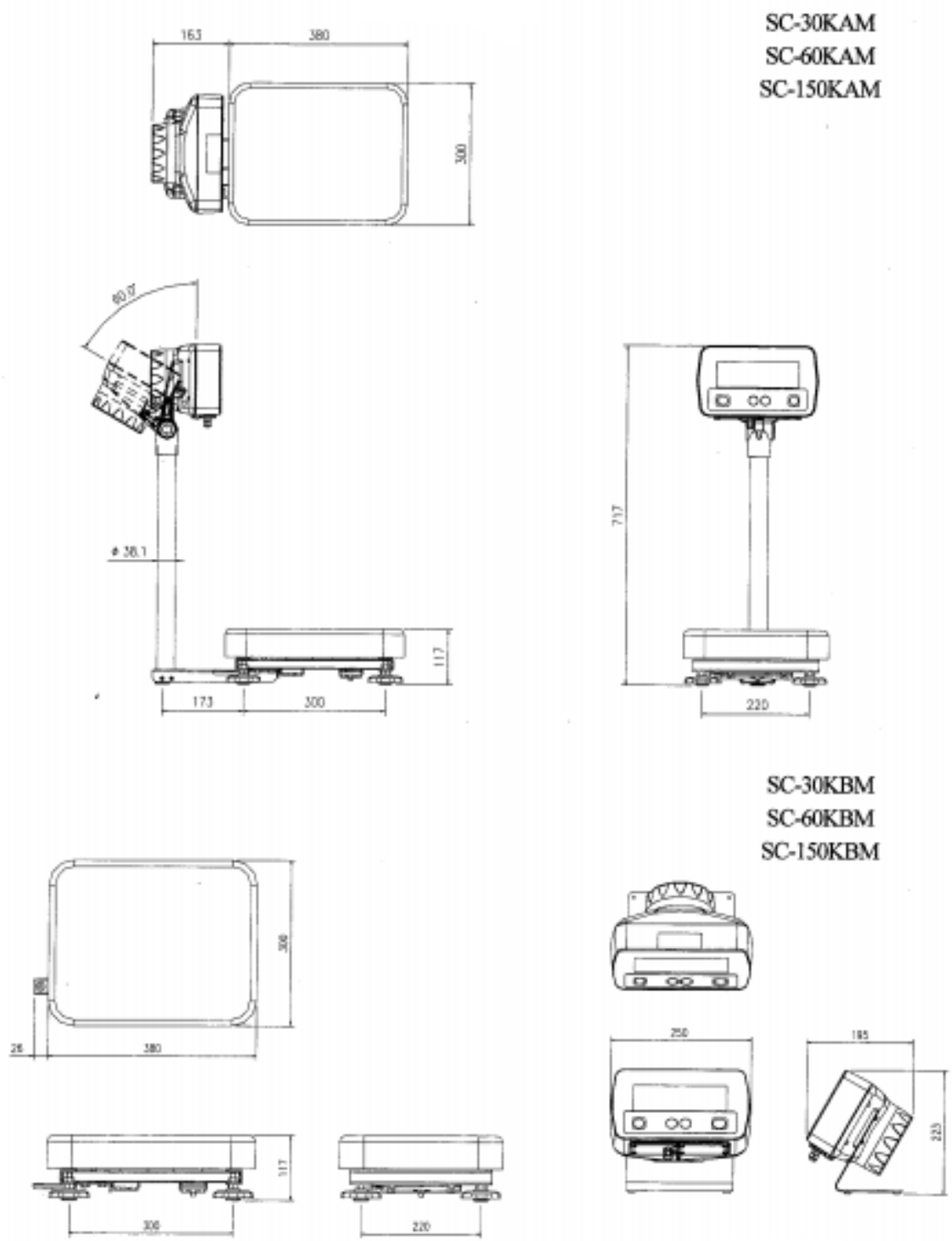

Figure 2 SC Series

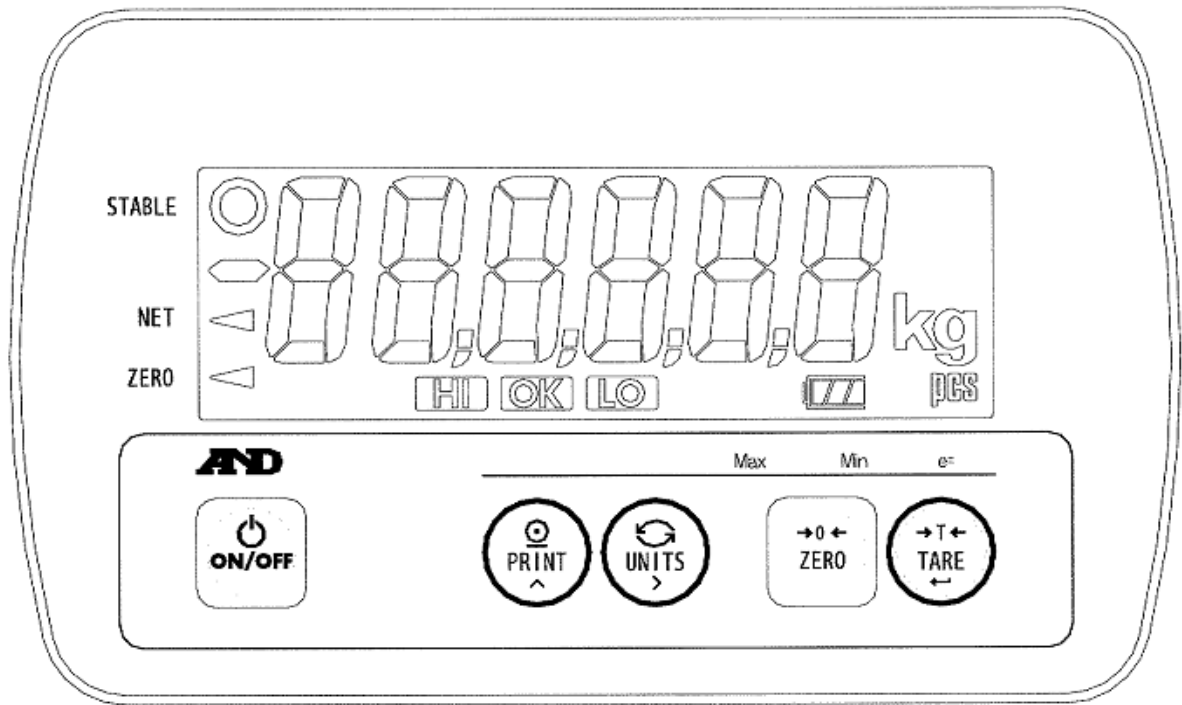

Figure 3 Display & legends

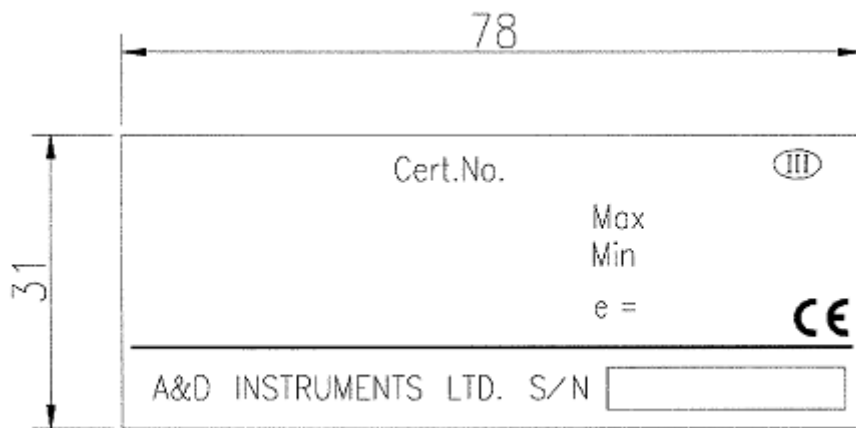

Figure 4 Data plate

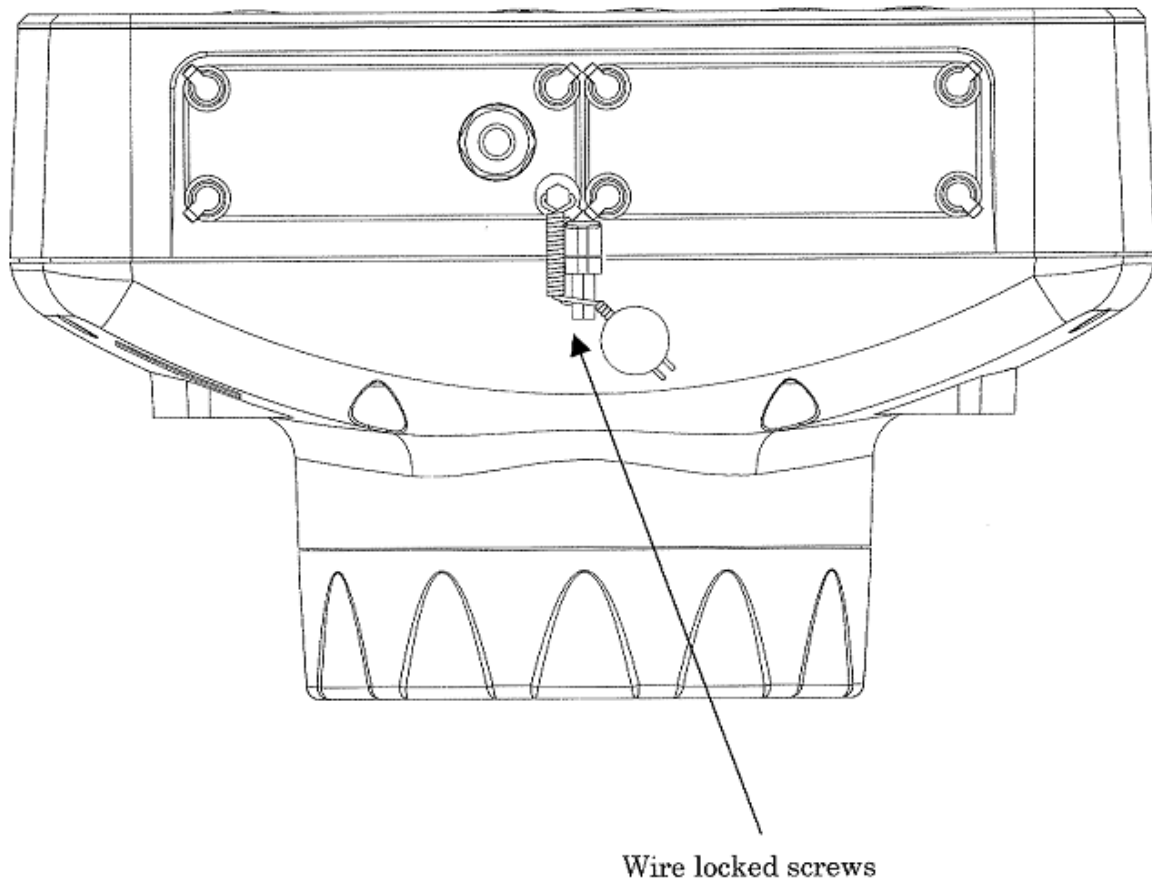

Figure 5 Sealing diagrams