



OPERATION MANUAL

Shaking Incubator

Model : ISS-3075, ISS-4075, ISS-3075R, ISS-4075R

Manual no. : 2D001L002 Version :0.0

⚠ WARNING

Before using this product, read this entire Operator's Manual carefully. Users should follow all of the Operational Guidelines contained in this Manual and take all necessary safety precautions while using this product. Failure to follow these guidelines could result in potentially irreparable bodily harm and/or property damage.

Thank you for purchasing Jeio Tech's products.

We are doing best for customer's satisfaction.

Quality Management System



Jeio Tech Co, Ltd. is dedicated to providing world-best product quality and customer satisfaction. To ensure we maintain this commitment we have developed and implemented a total quality program, which conforms to the requirements according to DIN EN ISO 9001:2008 for the design, development, production, sales and servicing of biotechnology, environmental chemical engineering related products, and reliable measuring equipment for electric and electronics (ovens, incubators, constant temperature humidity chambers, constant temperature baths, refrigerating bath circulators, heat exchangers and shakers).

Visit our Web site at www.jeiotech.com to view a copy of our certificate.

Disclaimer

Jeio Tech Co., Ltd. is committed to a continuing program of product development and improvement, and reserves the right to change information, such as specifications, appearance, and dimensions, described in this document without notice.

Copyright

No part of this manual may be reproduced or transmitted in any form or by any means, including photocopying, recording, or using information storage and retrieval systems, for any purpose other than the purchaser's own use, without the express written permission of Jeio Tech Co., Ltd.

©2014. All Rights Reserved. Jeio Tech Co., Ltd.

Any other product names and services identified in this manual are trademarks or registered trademarks of their respective owners. No such use, or the use of any trade name, is intended to convey endorsement or other affiliation with Jeio Tech Co., Ltd

Table of Contents

1 Safety	1
1.1 How to use the manual.....	1
1.2 Symbols used in this Manual	1
1.3 Exemption for responsibility.....	2
1.4 Caution statement.....	2
1.5 Caution statement for safe use	3
2 Functional Description.....	5
2.1 Introductions.....	5
2.2 Features	5
2.2.1 High Performance	5
2.2.2 Advanced Convenience.....	5
2.2.3 Advanced Safety.....	6
2.3 Structure.....	7
3 Installation	10
3.1 Unpacking and Checking.....	10
3.2 Component.....	10
3.3 Preparation before installation	12
3.3.1 Space requirements	12
3.3.2 Environmental Setting	13
3.4 Installation.....	14
3.4.1 Caution for Installation.....	14
3.4.2 Stacking the two units.....	15
3.5 Attaching Condensate Drain.....	16
3.6 Attaching/Detaching External Refrigeration (ISS-3075, ISS-4075 Only).....	17
3.7 Connecting Power	17
4 Operation	19
4.1 Controller.....	19
4.2 How to use the controller.....	20
4.2.1 Temperature control.....	21
4.2.2 Shaking Control.....	22
4.2.3 Shaking Timer	23
4.2.4 Alarm and Stop by force.....	23
4.2.5 Defrost (Refrigerated model, ISS-3075R, ISS-4075R Only).....	25
4.3 General Settings.....	26
4.4 System Settings.....	26

4.4.1	Control Deviation Limit.....	2 7
4.4.2	External Start/Stop Key.....	2 7
4.4.3	Calibration.....	2 8
4.4.4	Auto Tuning.....	2 9
4.4.5	Operating Parameters.....	2 9
4.4.6	Reset.....	3 0
4.5	Safety Tool	3 0
4.5.1	Over Temp. Limiter.....	3 0
4.5.2	High/Low Temp. Limiter.....	3 0
4.5.3	Glass Fuse.....	3 0
5	Maintenance.....	3 1
5.1	Inspection Period.....	3 1
5.2	Cleaning.....	3 2
5.3	Air filter cleaning (ISS-3075R/ISS-4075R)	3 3
5.4	Fuse Replacement.....	3 4
6	Troubleshooting	3 6
6.1	Stop during the operating	3 6
6.2	Another problem and solution.....	3 7
7	Accessories.....	3 9
7.1	Mountable maximum quantity.....	3 9
7.1.1	Universal Platform + Flask Clamp.....	3 9
7.1.2	Universal Platform + Plastic Flask Clamp.....	3 9
7.1.3	Universal Platform + Funnel Clamp.....	3 9
7.1.4	Universal Platform + Microplate Holder.....	4 0
7.1.5	Universal Platform + Test Tube Rack.....	4 0
7.1.6	Spring Wire Rack +Flask.....	4 0
7.1.7	Dedicated Platforms.....	4 1
7.1.8	Rubber Mats.....	4 1
7.1.9	Universal Attachment.....	4 1
7.1.10	Lab Sticker.....	4 1
7.1.11	Wire Shelves.....	4 1
8.0	SW.....	4 2
8.1	Monitoring Program installation	4 2
8.2	Communication Protocol.....	4 4
8.2.1	Physical Layer.....	4 4
8.2.2	Model System number.....	4 4
8.2.3	Modbus Protocol Address Definition.....	4 4
8.2.4	Modbus Protocol Description.....	4 6

9.1 Technical Specifications	5 0
9.2 How to use High/Low Temp.....	5 0
9.3 Disposing of products	5 2
9.4 Warranty.....	5 2
9.4.1 Terms of Warranty Service.....	5 2
9.4.2 Warranty exception	5 2
9.4.3 Service and technical advice	5 3

DOMINIQUE DUTSCHER SAS

1 Safety





1.1 How to use the manual

This manual is intended for individuals requiring information about the use of product. Use this manual as a guide and reference for installing, operating, and maintaining your Jeio Tech product. The purpose is to assist you in applying efficient, proven techniques that enhance equipment productivity

This manual covers only light corrective maintenance. No installation, service procedure or other maintenance should be undertaken without first contacting a service technician, nor should be carried out by someone other than a service technician with specific experience with laboratory equipment and electricity

1.2 Symbols used in this Manual

- (1) The alert marks are for safety operation and protect user and instrument from Damage.
- (2) Signal word panels are a method for calling attention to a safety messages or property damage messages and designate a degree or level of hazard seriousness.
- (3) Pay attention enough to the contents of alert marks.

Signal word panels	Uses
	Indicates a hazardous situation which, if not avoided, will result in death or serious injury
	Indicates a hazardous situation which, if not avoided, could result in death or serious injury..
	Indicates a hazardous situation which, if not avoided, may result in minor or moderate injury.
	Indicates a property damage message.

1.3 Exemption for responsibility

- (1) The claim which is out of the quality guaranteed by the manufacturer is out of manufacturer's responsibility.
- (2) The damage which is from unexpected fault or damage of user by Acts of God is out of Manufacturer's responsibility.

1.4 Caution statement

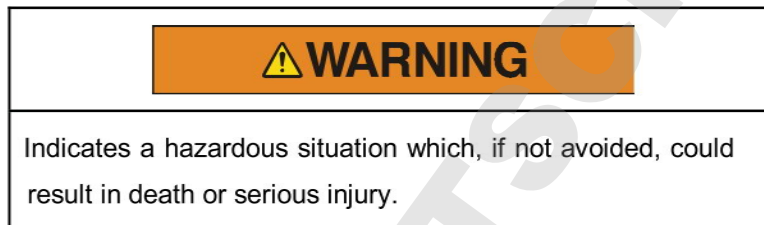

Please use the product in safety facility installing laboratory in case of accident. Installed the product on durable and flat surface.

Please, make sure safety equipment with relevant provision before handling the sample which may cause flammable or toxic gases.

Do not use the machine near to places where explosion can be happened due to organic evaporating gases.

Explosive materials: Acid, Esther, Nitro compound

Inflammable materials: salt peroxides, inorganic peroxide, salt acids.

Do not use the machine at places where moisture is high and flooding can be happened.

Please check and connect properly -the voltage, phase and capacity of power supply on the ID plate before installation.

Be sure to install a separate power wiring and use a dedicated power supply.

Power supply must be properly grounded.

Abnormal grounded connection causes serious damage. Grounded connection must not be on the water pipe and gas pipe.

Put off the power plug if some sounds and burning smell, smokes are happened. And request the service

Stop the product operation and request service.

Do not assemble, repair, modify on your own.

The product may not work well and electric shock in the efficiency of the product. Also you cannot get after service by warranty regulation

1.5 Caution statement for safe use

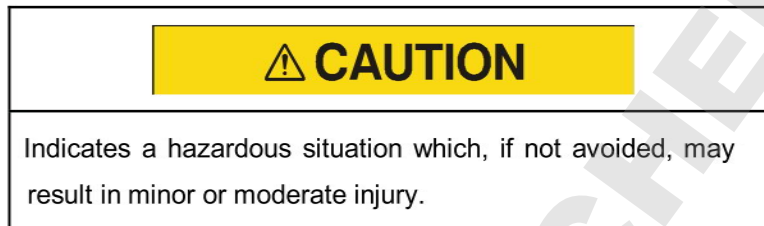

Be sure to disconnect the power after turning off the power switch.

This is the safety regulation for next user.

Do not put heavy things on the power line. Do not put the machine on the line.

It may take off the wire coating and causes the electric shock or fire.

Do not touch it with wet hands and put the main plug correctly.

It may cause the electric shock or injuries.

Do not inject any liquid and inflammable things inside of product.

Do not let the product take any strong shock or vibration.

It causes abnormal operation or trouble. It may deteriorate the ability of the product and not obtain correct results.

Do not install the stirrer neat machinery generating high frequency noise.

Please avoid installed from high frequency- welding machine, sewing machine, and mass SCR controller

Do not sprinkle insecticide or flammable spray on the product. Use smooth cloths.

Cleaning with solvent can cause fire and deformity.

Please power off while product cleaning.

It may cause the electric shock or fire



Wear protective gloves.



Wear eye protection.



No water



No corrosive



Electrical shock.



Flammable



Foot crush.



Hand crush or pinch.



Lifting hazard.



Do not take the device apart
deliberately.

2 Functional Description

2.1 Introductions

The cultivation environment such as temperature, pH, oxygen concentration, nutrition supply have a significant impact on cell cultures of animals and plants or proliferation of microorganisms.

This incubated shaker is to provide a suitable environment for the cultivation through controlling constant temperature and shaking speed.

- Cell culture
- Extractions
- Solubility studies
- Hybridization
- Plasmid purification
- Protein expression

2.2 Features

2.2.1 High Performance

(1) Precise and fast temperature / shaking speed control is available by microprocessor PID feedback control. PID feedback control ensures the same experimental environment conditions for the user. The device's deviation of set temperature and set rpm are each under ± 0.1 °C (standard: 37 °C), $\pm 1\%$ (standard: set rpm) which are regarded as very precise value. If the deviations go above a certain level, alarm will be activated to the user.

(2) Control range of temperature and stirring speed is wide. Temperature control up to 60 °C and stirring speed control up to 500rpm are available to provide users wider experimental conditions.

(3) Optimizing the structural design of the product enables stable shaking even with heavy load. Low center of gravity minimizes noise and vibration.

(4) More precise temperature control by 3ea temperature points.

User can mate temperature measuring instrument and the unit's temperature by 3 temperature points.

2.2.2 Advanced Convenience

(1) User friendly interface according to Touch LCD. Eidetic unit operation check and easy to control.

(2) Timer and operation time check of shaking performance is available. Setting and checking the value is available up to 999 hours and 59 minutes.

(3) Large window with LED lamp on the door offers the convenience to monitor the samples in the chamber without opening the door in the dark place.

(4) Easy connection from Unit to PC with RS232 Port and USB port and it allows easy monitoring and control.

- (5) By providing an automatic power failure recovery, even if the product gets power back after a momentary power failure, the auto run function automatically runs the product.
- (6) It is stackable up to two levels, beneficial for the space efficiency.
- (7) Two adjustable-height shelves are provided to allow static incubation, which increase storage capacity
- (8) In case of the liquid leakage caused by spilled reagent or cracked flask inside of the chamber, the liquid is designed to be drained out through the drain of the chamber bottom which is connected to the port on the product's side.
- (9) This equipment is more convenient when mounting / desorption of the sample. When shaking performance, operation always starts and stops at a specified location, the platform is fixed to easily replace the sample

2.2.3 Advanced Safety

- (1) Smooth shaking start and stop mechanism minimizes the opportunity of reagent leakage.
- (2) Unit can control possible RPM speed when the shaking that unit cannot control due to (overload & high RPM, weight imbalance) is operated. There is no movement due to shaking vibration
- (3) There is an independent adjustable temperature limit device in addition to the main controller in this device. If temperature rises more than the specified value due to equipment error, the independent device protects the internal sample and equipment by blocking the power supply of the temperature-related equipment.
- (4) When shaking operation is not possible due to the obstacle interfering the system, over current protection device stops the operation.

2.3 Structure

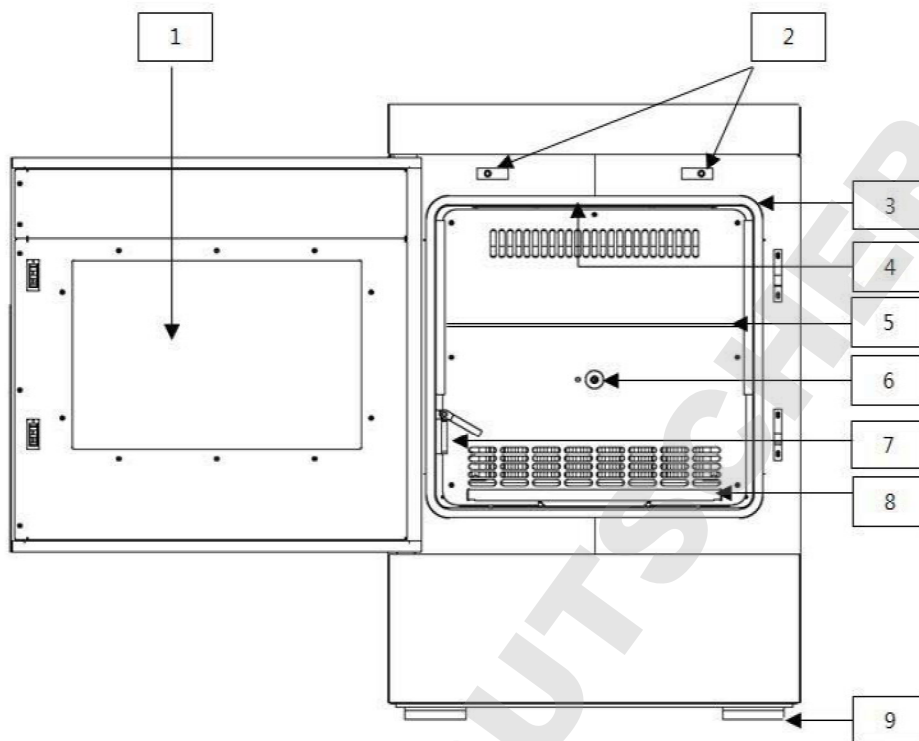

(1) Transparent Viewing Window

User can monitor the inner samples without opening the door during operation.

(2) Door Switch

There is a door limit switch between the door and the appliances mainframe's front parts. If the door is opened, Shaking, Blower and Heater operation automatically stops. After 3 minutes at this status, warning sound alarms users to close the door. If a user does not shut a door so that five minutes passes, and an alarm sound continuously rings. And it blocks off the power to be authorized with a power switch, and Off gets a power switch done and all blocks off 2 phase of the power supplied with to an each part of appliances, and configuration does the safe state that only a Ground part is connected.

(3) Door Packing

It absorbs the shock when opening/closing the door and seals up the chamber.

(4) LED Lamp

Long life span and energy efficient LED lamp offers bright observation of samples.

(5) Shelf

Two adjustable-height shelves are provided to allow static incubation, which increase storage capacity

(6) Temperature Sensor

It is Pt 100Ω sensor that temperature and resistance values are shown as the linear format and response speed is fast.

(7) Inner Outlet

The consent inside of chamber is beneficial for using small laboratory equipment in the chamber. The maximum current is 2.0A.

(8) Shaking Table

Shaking table is connected to a shaking system and Accessory such as Universal Platform can be equipped on shaking table. (Universal Platform is equipped in the figure.)

(9) Foot

Foot fix the device for stable operation.

(10)Control Panel

There are independent displays for each Temperature, RPM, Timer and there are and start/stop buttons and LED on/off buttons.

(11)Door Handle

To open/close the door

(12)Computer Interface

This unit can connect to PC by USB port and RS232 port.

If it is connected, PC can monitor the unit operation status and start the unit operation.

USB is connected preferentially if USB and RS232 are connected at the same time.

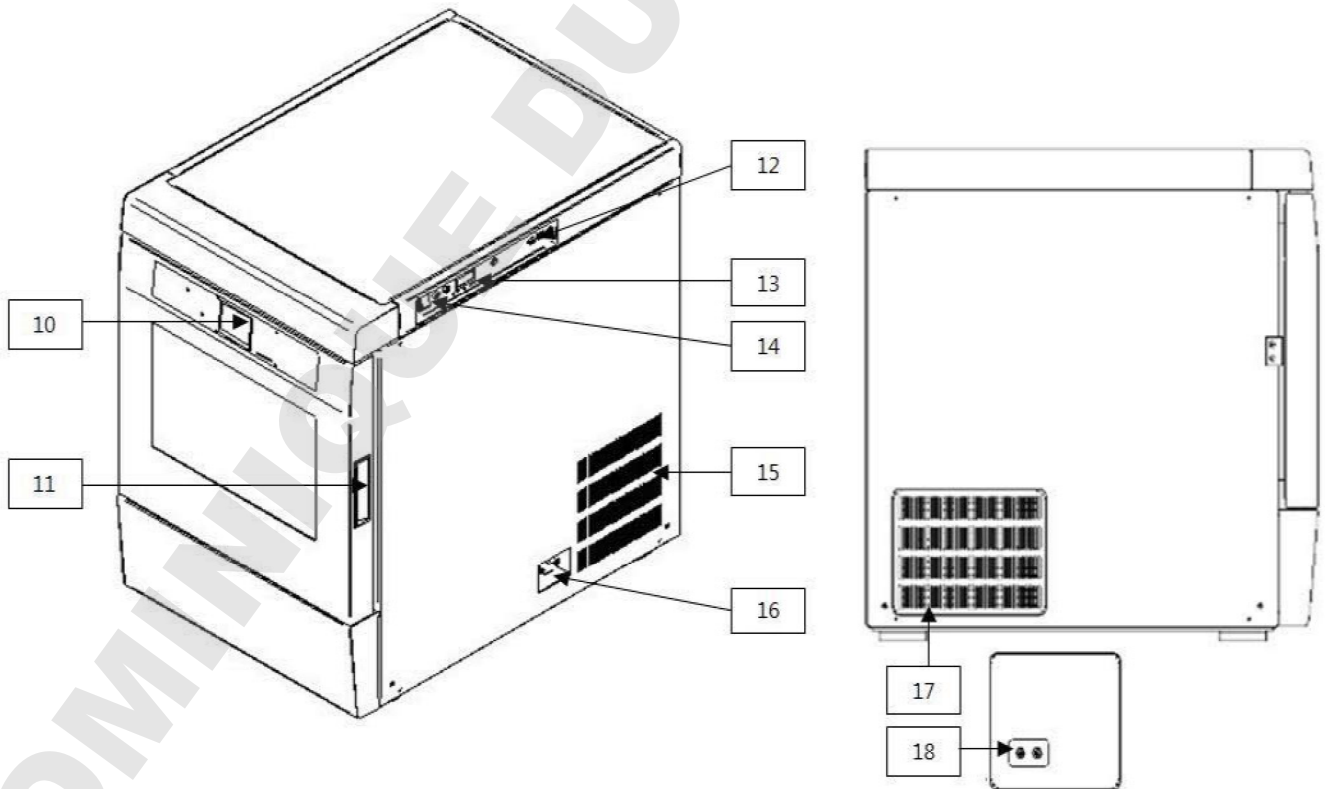

(13) Temperature Limiter

Temperature limiter is independently configured from the main controller. The inner temperature

of the chamber exceeds more than the set temperature, the device cut off the power to the power switch for the secure condition. (Refer to '4.5 Safety Device')

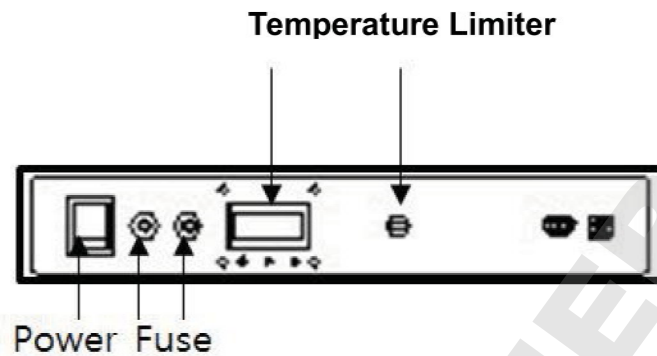

(14) Power Switch and Fuse

Power switch provide the main power to the device. Fuse protects the device from instantaneous overcurrent. In case of fuse replacement, check the rated power. (Refer to 5.4 Fuse Replacement)

(15) Refrigerating System (ISS-3075R/4075R only)

It circulates refrigerant in the chamber. It is operated in case of low temperature control.

(16) Spill Drain and Condensate Drain

In case of the liquid leakage caused by spilled reagent or cracked flask inside of the chamber, the liquid is designed to be drained out through the drain of the chamber bottom which is connected to the port on the product's side. (Refer to '3.5 Drain connection')

(17) Condenser Cover and Filter (ISS-3075R/4075R only)

Attachable condenser cover and filter prevent dust to the inside system.

(18) External Refrigeration Port (ISS-3075/4075 only)

Even if the model such as ISS-3075/4075 which has no refrigerator, It can lower the temperature in the chamber by receiving refrigerant from the external refrigerant device such as chiller. The In/out ports (refer to the figure) are located on the back and bottom side of the device. These brass push-to-connect fittings accept $\varnothing 8\text{mm}$ OD hard-wall tubing and provide access ports for external refrigeration.

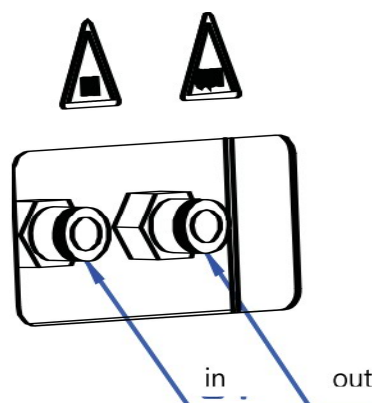



3 Installation



3.1 Unpacking and Checking

- (1) Inspect the shipping container carefully for any damage.
- (2) Remove the outer container.
- (3) Before use, inspect the product carefully for any damage that may have occurred during shipping.
- (4) Report any damage to your local Jeio Tech office or the distributor.

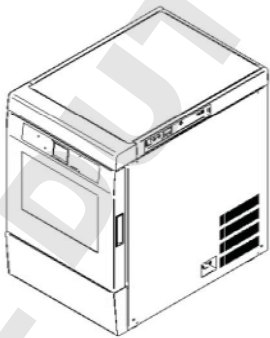
3.2 Component

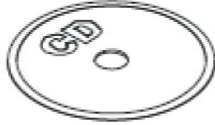
- (1) After unpacking, check the components.
- (2) In the case of omission of components, contact to Jeiotech.

Item	Figure	Quantity	Description
Main Body		1	
Shelves (Brackets)		2 (8)	
Fuse			
JEIOTECH SOFTWARE CD		1	

Cable for Communication (USB)		1	-
Power Cord		1	-
Operating Manual		1	

DOMINIQUE DUTSCHER SAS

3.3 Preparation before installation

3.3.1 Space requirements

It is essential that the product to be situated in an area where there is sufficient space for the product. Below figures show the minimum space requirements needed to properly operate and maintain the product.

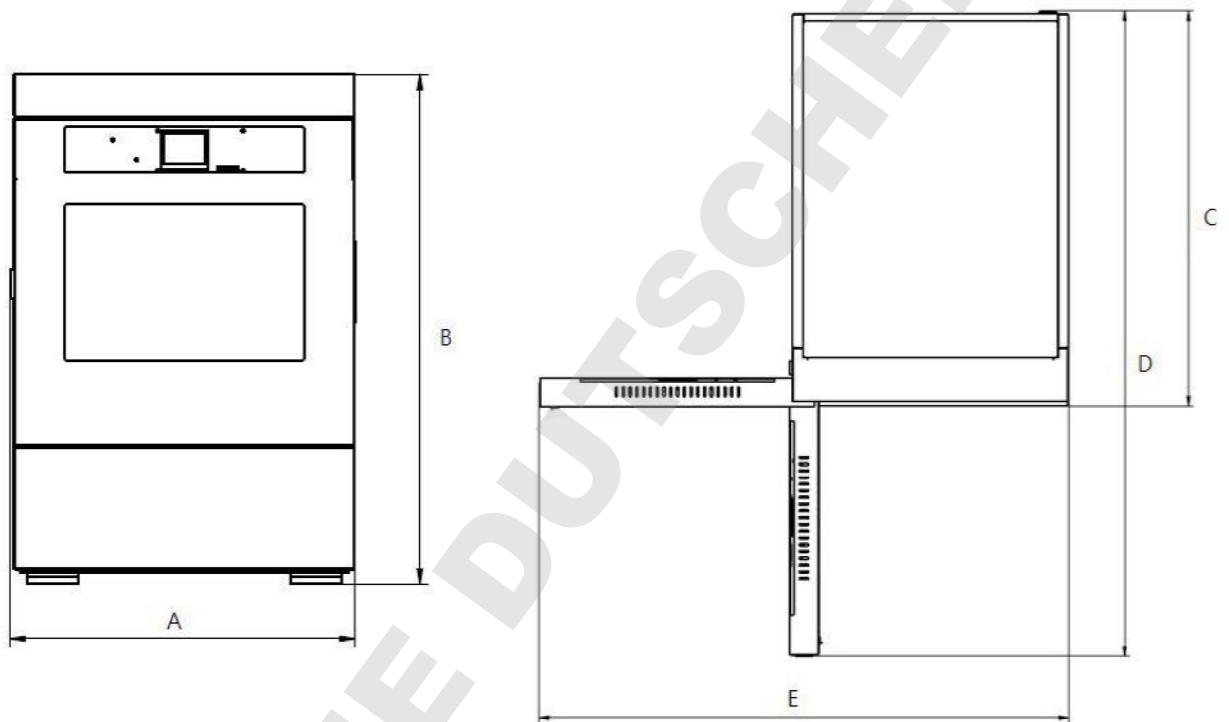

Dimensions (mm) / Models	A	B	C	D	E
ISS-3075(R)	578	854	815	1335	1094
ISS-4075(R)	678	934	895	1515	1294

3.3.2 Environmental Setting

The unit can be operated properly under the following environmental conditions for a long time running without any problem.



No direct sunlight on the product



Ambient temperature: 5°C ~ 40°C (41°F~104°F)



Relative humidity not to exceed 80%



Altitude not to exceed 2000m (6,562 feet)



Connect the product to earth grounded terminals only.

WARNING

- Please install on the sturdy surface laboratory which is set safety facility and make sure horizontal align correctly.
 - Do not use the Product near environments where flammable gas may leak.
 - Moving casters must be changed height adjustable foots so that the unit is not moving.
-

3.4 Installation

3.4.1 Caution for Installation

- (1) The device is recommended to use under the room temperature and humidity (30°C, 80%RH) do not install it near the Heat devices like a Heater.
- (2) Have enough space for door opening. (refer to 3.3.1)
- (3) Please install it on the sturdy surface laboratory and do not throw down or gives a big shock.
- (4) Locate it 1.5m away from any light devices and 30 CM away from the wall.
- (5) Install it on the sturdy leveled surface to prevent abnormal turbulence and noise.

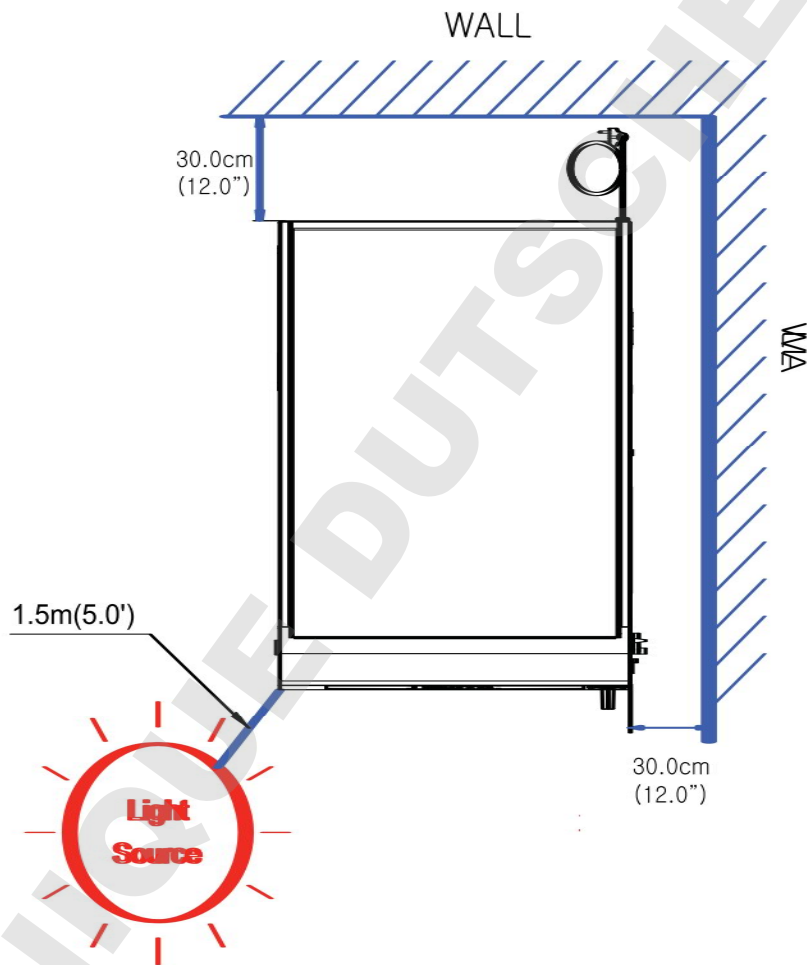

3.4.2 Stacking the two units

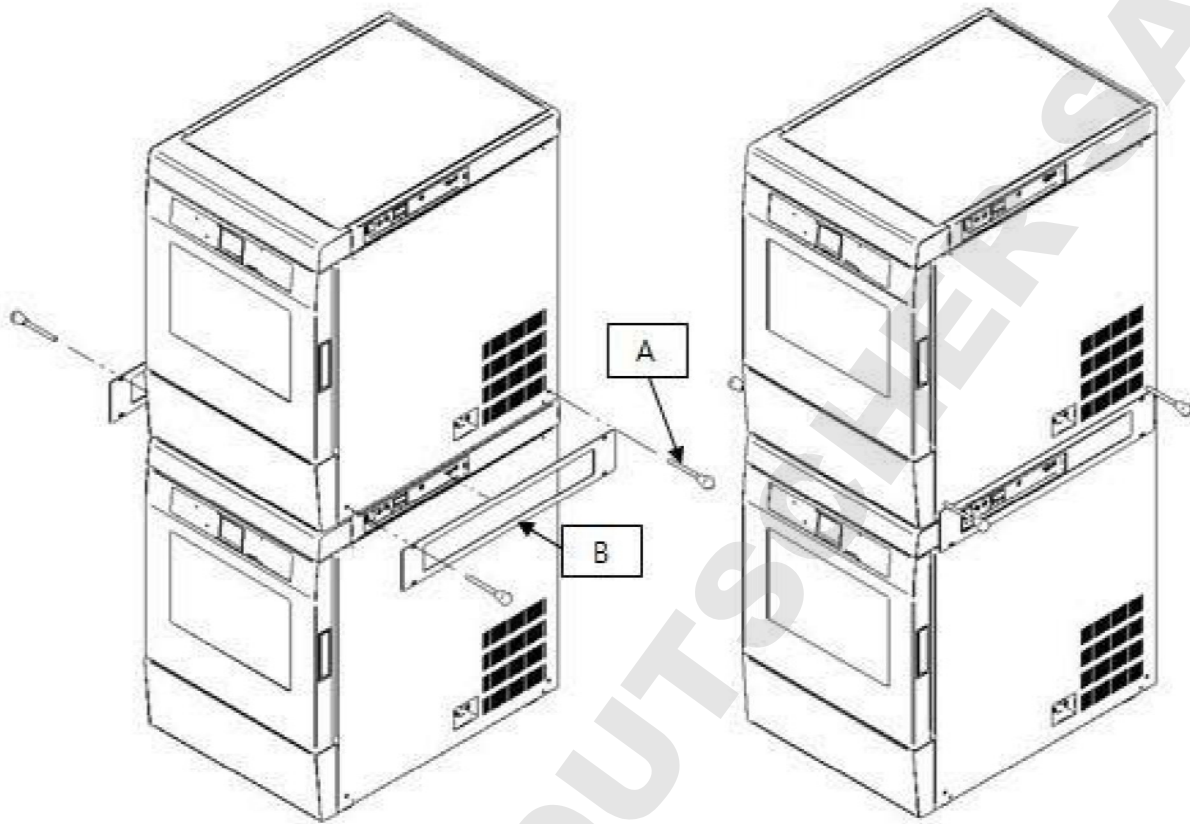

[The location of the handle and bracket]

In the case of stacking two units, using the bracket stacks the two units. The procedure is same as below.

- (1) Lift the unit and remove the feet one by one.
- (2) Put the handle(A) into the four places of the foot removed and lift up.
- (3) Using the bracket(b) and bolts, fix the upper and lower units.
- (4) Remove the handle.

3.5 Attaching Condensate Drain

In case of the liquid leakage caused by spilled reagent or cracked flask inside of the chamber, the liquid is designed to be drained out through the drain of the unit. The drain barb is made of chromium plated copper and it is easy to connect 6mm ID soft-walled tubing to the condensate drain.

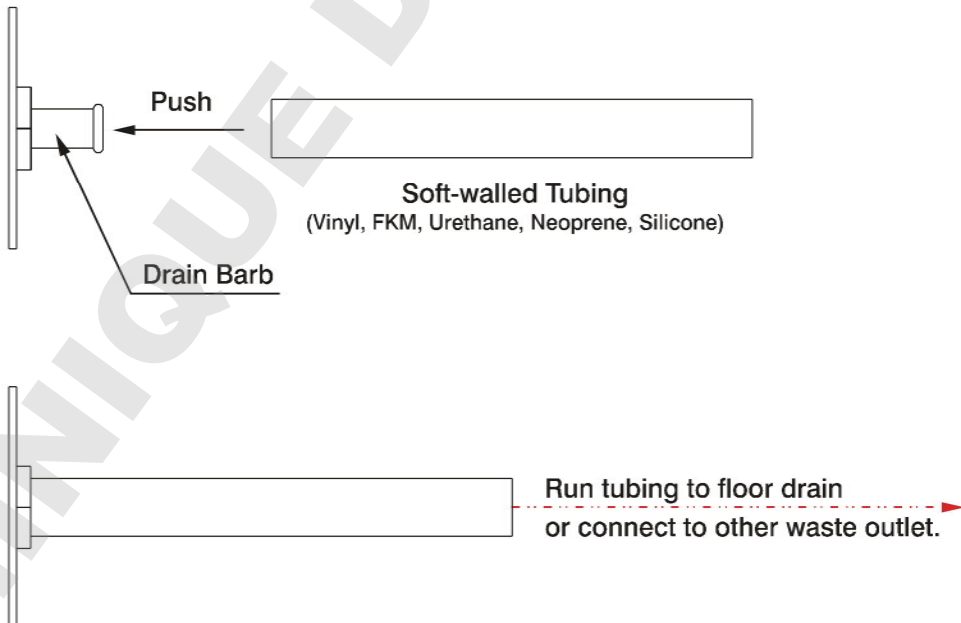
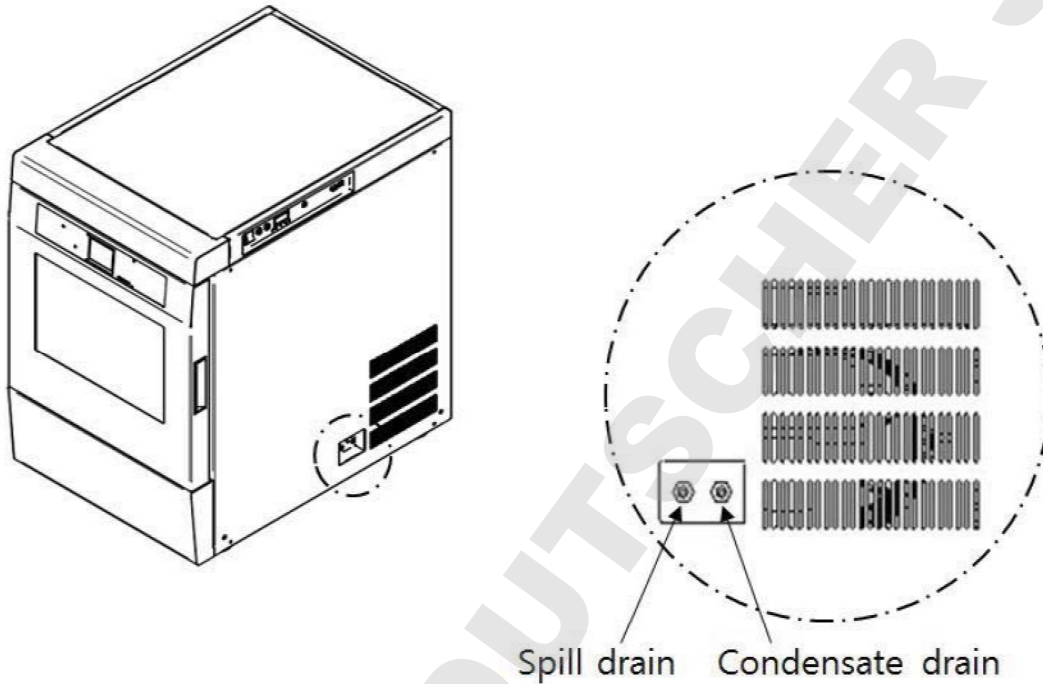

3.6 Attaching/Detaching External Refrigeration (ISS-3075, ISS-4075 Only)

Many laboratories are built with central chilling systems. With this in mind Jeio Tech has developed the ISS-3075/4075 so that it can be connected to external refrigeration systems. To connect the unit to an external refrigeration source use Ø8mm OD hard-walled tubing, such as nylon or polyethylene. Note: The ISS-3075/4075 controller does not have the ability to communicate with the external refrigeration source. Use the following procedure to connect/disconnect the tubing to the unit. Use the following procedure to connect/disconnect the tubing to the unit.

(1) Inserting tubing into fitting

Hold the tubing firmly and push it tightly into the fitting. Run the tubing to the external refrigeration source.

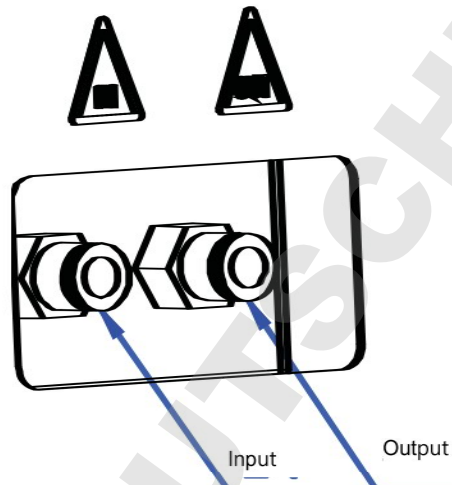

(2) Removing from fitting

Grab the tubing tightly and push towards the incubated shaker as you firmly push the collet release button with two fingers. Continue to push the collect release button, and pull the tubing out of the fitting.

3.7 Connecting Power

JEIOTECH's Shaking Incubators use a single-phase current. Use a suitable plug as the picture bellow by Identification label. Voltage is the 10% of applied voltage.

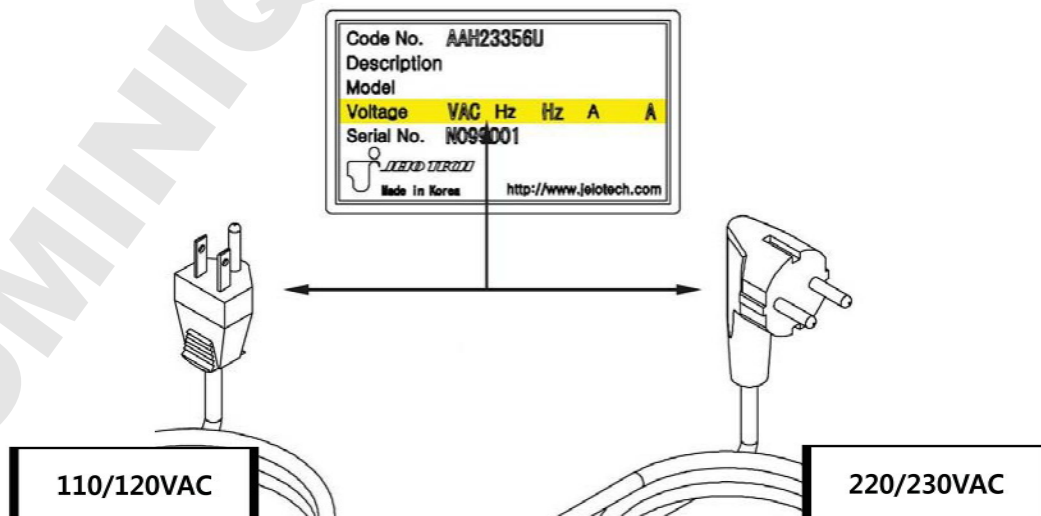

 **WARNING**



- Connect the power with checking the voltage, Phase, Capacity.
 - Use the ground power for the connection.
 - Do no use the double cap or a current tap socket causing a damage on the cable and fire due to an overcurrent.
-

4 Operation

4.1 Controller

The controller is consist of the touch screen, LED, membrane. Once the power is supplied, below display is appeared.

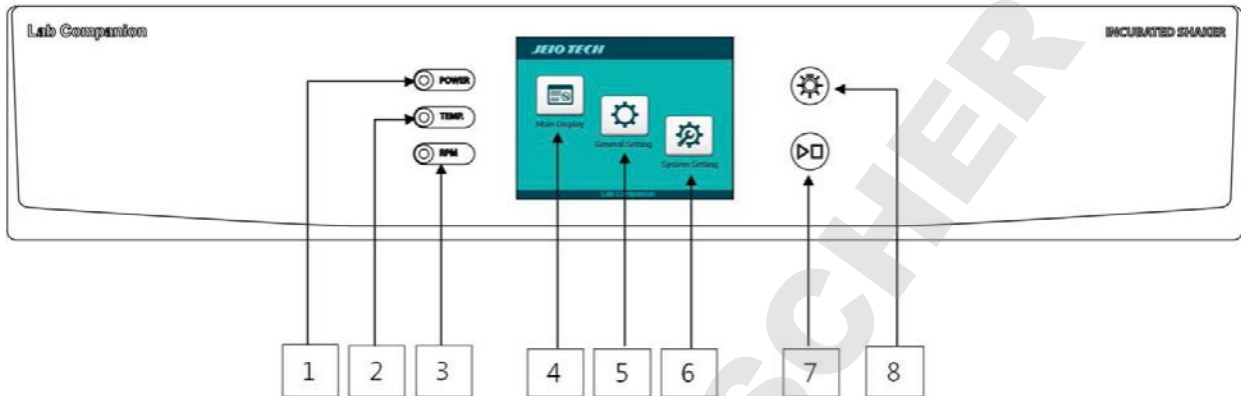







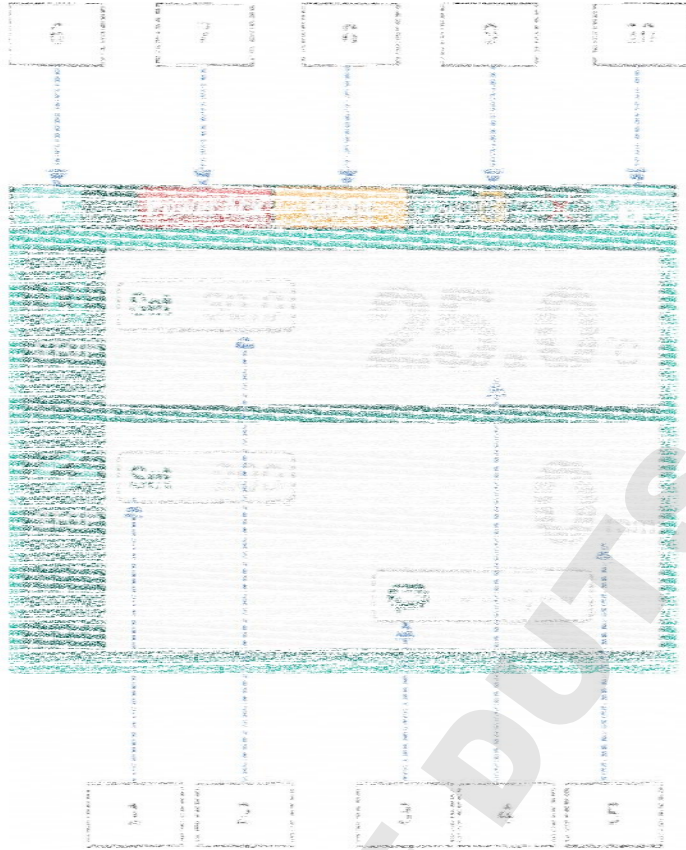



1	Power ON indicator	Power is supplied.
2	Temperature Control ON indicator	Under the temperature controlling.
3	Shaking Control ON indicator	Under the shaking controlling. In the case of the timer is set, it is off.
4	Main Display	Main Display for the operation.
5	General Setting	General setting.
6	System Setting	Parameter setting is available. For change the parameter, acknowledge the manual.
7	Quick Start/Stop	Touch button is the base. Start/Stop external button is installed on the controller for the user's convenience. Function setting is available on the system setting. (Default: shaking start/stop)
8	LED Lamp	On/Off the LED lamp.

4.2 How to use the controller

Setting is available on the main display.



1	Set RPM	Display the setting RPM. Touch the screen, set the RPM.
2	Set Temperature	Display the setting temperature. Touch the screen, set the temperature.
3	Set Timer	Display the shaking time. Touch the screen, set the timer. In the case of no timer is set, the operating time is displayed. (999hours 59minutes)
4	Actual Temperature	Display the temperature of inside of chamber.
5	Actual RPM	Display the present shaking speed.
6	Back	From main display to home display. It is available when the unit is stop the operating.
7	Power Ack	In the case of the power is off for the supply faulty reason and the supply is back, the previous operating is back. It is auto restart function. At the time Power-Ack button is appeared on the display. In the case of the shaking was operating, the operating time is appeared on the display with red words. Once touch the Power-Ack or change the setting value, The Power Ack display is disappeared.

8	Silent	In the case of attention on the unit is required, the unit generates the alarm. Touch the silent, the unit stops the alarm. Once the problem is not eliminated, the unit generates alarm again.	
9	Status Bar		The unit stops the platform on the same position. This display indicates that the platform is on the right position. If the platform is not on the right position, the color will be changed as yellow.
			The unit provide USB port and RS-232 port. The display is on when the computer is connected. Report Only :  / Slave Mode : 
			Door is opened.
			LED lamp is on.
			Mute function. The setting is available by the General Setting.
10	Lock	The lock function is to prevent the not proper setting change. Once touch the button, the display is changed same as  . To unlock it, touch twice of the button.  -> 	
11	Defrost	In case of refrigerated model, automatic defrost is activated regularly. When defrost process, defrost mark is shown next to Present temperature value on display.	

4.2.1 Temperature control

- (1) Start temperature control
- (2) Touch the set temperature button on the main display. Setting display is appeared. Set the temperature with touch pad and touch the start button. The temperature control starts. SV and PV is displayed on the main display with green color.
- (3) Stop the temperature control
- (4) Touch the set temperature button. Setting display is appeared. Touch the stop button. The temperature control stops. The temperature control starts. SV and PV is displayed on the main display with gray color.
- (5) Change the set temperature
- (6) Touch the set temperature button. Setting display is appeared. Put the setting value on the touch pad and touch the enter button. SV is changed.

NOTICE

- Temperature setting is one digit and one decimal point available. Touch the panel and put the numbers.
 - Move out from the setting mode with ESC button.
 - In the case of no touch for 10 seconds, the display changed to the main automatically.
 - Check the PV, RPM on the setting display is available. (right upper side)
 - The operating is maintained as previous during the setting.
 - Once the door is opened during the shaking operating, the heater and fan is stopped. Close the door before door error generating, the previous operating is back.
-

4.2.2 Shaking Control

(1) Start shaking control

Touch the Set RPM Button under the shaking stop status. Setting mode is appeared. Set the value on the display and touch the Start button. Shaking control starts. SV/PV rpm is changed to green color.

(2) Stop the shaking control.

Touch the Set RPM button under the shaking operating status. Setting mode is appeared. Touch the Stop button. Shaking stops. SV/PV rpm is changed to gray color.

(3) Change the shaking speed

Touch Set RPM button. Setting mode is appeared.

Set the value on the display and touch the Enter button. The rpm is changed.

NOTICE

- Move out from the setting mode with ESC button.
 - In the case of no touch for 10 seconds, the display changed to the main automatically.
 - Check the PV, RPM on the setting display is available. (right upper side)
 - The operating is maintained as previous during the setting.
 - Once the door is opened during the shaking operating, the heater and fan is stopped. Close the door before door error generating, the previous operating is back.
-

CAUTION

- In the case of change the sample, stop the shaking and check whether the platform is completely stopped.

4.2.3 Shaking Timer

Timer is only available for shaking. Once the timer is set, the shaking stops after operating the set time and beep is generated. Setting time is on the display once the timer is set and '---:--' is on the display once the timer is not set. Remaining time is on the display once the timer is set and accumulated time is on the display once the timer is not set.

(1) Timer ON

Touch the Set timer on the main display. Timer OFF is on the display once the timer is set and Timer on is on the display once the timer is not set. Touch the Timer ON button and set the time on the display. Touch the Enter button. Check the set time on the main display.

(2) Timer OFF

Touch the Set timer on the main display. Timer OFF is on the display once the timer is set and Timer on is on the display once the timer is not set. Touch the Timer OFF button and touch the Enter. Time display on the main display is changed to "---:--".

(3) Change the setting time

Touch the Set timer on the main display. On the Timer ON status, put the time on the display. Touch the Enter. Check the changed time on the main display.

NOTICE

- Once the setting time is changed during the timer operating, original set time is changed. The accumulated time is applied to the new time setting and the remaining time is calculated and displayed. If you want whole new time setting, off the timer and set the timer again.
- Timer setting is available for hour:minute. Touch the part you want to change and put the numbers on it.
- Move out from the setting mode with ESC button.
- In the case of no touch for 10 seconds, the display changed to the main automatically.
- On the timer set display, you can check the present chamber temperature and rpm. (right upper side of the display)
- Below 1 minutes is displayed as "mmm:ss".
- Timer is not counted during the door open.

4.2.4 Alarm and Stop by force

The unit senses the problem on the unit and warn to the user. The warning is visual-audial effect. The alarm is divided into warning and fault.

4.2.4.1 Warnings

Warning generates visual-audial alarm but the unit is operating. Once the warning is generated, Silent button is appeared on the main display. Once the silent button is touched, next 15 minutes there is no alarm. If the problem is on-going after 15 minutes, the alarm is generated again.

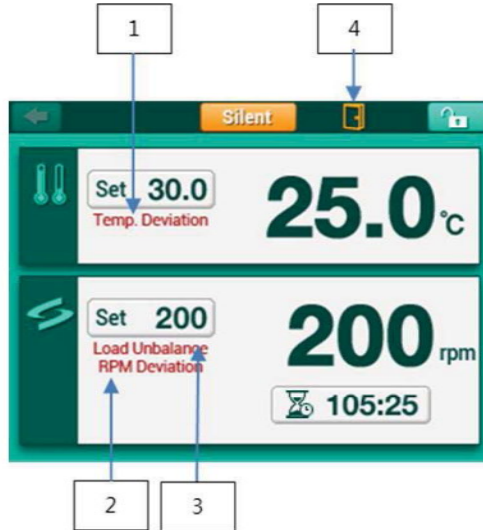

1	Temp. Deviation	The temperature difference between setting temperature and present temperature is more than the range of the permission. The unit check it once the present value reached to setting value. Once the gap is over the permission range, the alarm is generated.
2	RPM Deviation	The rpm difference between setting rpm and present rpm is more than the range of the permission. The unit check it once the present value reached to setting value. Once the gap is over the permission range, the alarm is generated.
3	Load Unbalance	Once the shaking system is vibrated by the present operating, the system adjusts the shaking speed to the controllable stage. This is on the display.
4	Door Open	Once the door is opened, the temperature and rpm are not operated. Once the door is opened, visual-audial alarm is generated. After 3 minutes of door opening, the alarm is effective. Once the door is closed, alarm is eliminated and the operating is back.

NOTICE

- Alarm is not effective if Sound Off is set on the General Setting.
- Deviation Alarm is not effective once the present value reaches to the setting value. (set time, in permission range)
- Deviation alarm is initialized under the below situation.
 - Set the setting value
 - Get back to the work after stopping the control. (Door open, Stop operating)
 - Defrost is under progress (Temperature control)
- Once the Deviation initialized, the unit check the present value. If the temperature not reaches to the SV for 4 hours and the rpm not reaches to the SV for 10 minutes, Deviation check is started.
- The range of permission and the period of Deviation is changeable on the System Setting.
- Once Load Unbalance is generated and the setting rpm is changed, the changed rpm is on the display with red color.

4.2.4.2 Faults

Fault Alarm stops the unit and inform it to the user when the unit need forced stop for the protection. Fault alarm are Electronic/Mechanical over-temp protection, Load Unbalance, Door Open, Sensor Fault, Over Current.

1	Temperature Limit	Electronic/Mechanical over-temp Limiters on the right side of the unit is activated. The inner temperature of the chamber exceeded the set temperature of the limiter. The unit stops operation for protection of the product and the samples. Check the range of the set temperature of the over-temp limiters.
2	Load Unbalance	This error occurs when shaking operation cab not be activated due to shaking system's vibration. Unbalanced sample load, heavy sample load, unlevelled floor are the factors. To protect shaking system, shaking operation stops.
3	Door Open	If the door is opened for more than 5 minutes during operation, the unit stops operation and activates door open fault alarm.
4	Sensor Fault	It stops operation due to main controller's temperature sensor malfunction.
5	Over Current	Automatic shutoff in the situation when there is over-current to the unit. The factors are excessive shaking operation, substance disturbance in the shaking system.

4.2.5 Defrost (Refrigerated model, ISS-3075R, ISS-4075R Only)

The refrigerated model activates automatic defrost when the setting temperature is saved under

the certain temperature. The defrost operation can raise the temperature of the chamber. Also the defrost mark  will blink on display to indicate defrost progress.

NOTICE

- The defrost operation can raise the temperature of the chamber.
- If you stop the temperature control or set the temperature out of the range of defrost activation, the defrost period is initialized.
- The monitoring for Temperature deviation alarm is initialized during defrost progress
- User can set the use of defrost function. (4.4.5 Operating Parameters)

4.3 General Settings

Set the general operating. Touch General Setting button and below setting menu is appeared. Touch the '<' or '>' and explore the menu.

1	Shaking Direction	Set the shaking direction • CW(clock wise), CCW(counter clock wise)
2	Temperature Unit	C°/F°
3	Lock	Use the Lock or not
4	System Sound	Mute for sound or not
5	LCD Brightness	Adjust the brightness of LCD
6	LCD Auto Dim	LCD Dim function (No input, LCD dim)
7	Dim Brightness	LCD Dim, and the brightness of the dim
8	Dim Time Out	Waiting time for LCD Dim mode operating
9	Light Brightness	Select the brightness of LED
10	Light Auto	Door opened, auto LED light on
11	Auto Restart	Auto restart function. The unit is back to the operating, before the power out.(Time information is not back)
12	USB (RS232)	USB and RS-232 port is available for the PC. Select the mode when PC is connected. Report Only : PC received the information from the unit. Slave Mode : PC control the unit.

4.4 System Settings

Set the main variable that effect on the unit. Please read the manual carefully before setting the system. Touch the System setting button on the home display, below clauses are arranged.

1	Control Deviation Limit	Set the deviation limit range. Temperature setting and rpm setting are available.
2	External	Start/Stop membrane button is located on the control panel. Set about

	Start/Stop Key	this key
3	Calibration	Calibration on the temperature sensor and rpm to the user's reference. Calibration on the LCD touch coordinate is available.
4	Auto Tuning	Temperature PID parameter update. Optimum control on the main operating temperature is available.
5	Operating Parameters	Set the operating and error check
6	Reset	Set the parameter as initial factory value.

4.4.1 Control Deviation Limit

Set the deviation limit between setting value and actual value of the temperature and rpm. The time of out of deviation limit range can be set either.

1	Temperature Deviation Limit	Set the deviation limit between setting value and actual value. Set on the key pad.
2	Temperature Deviation Alarm Delay	Once the deviation is out of range for alarm delay period, the alarm is generated. Once the actual temp reached to the set temp, the alarm is disappeared after alarm delay period check.
3	RPM Deviation Limit	Set the deviation limit between setting value and actual value. Set on the key pad.
4	RPM Deviation Alarm Delay	Once the deviation is out of range for alarm delay period, the alarm is generated. Once the actual rpm reached to the set rpm, the alarm is disappeared after alarm delay period check.

4.4.2 External Start/Stop Key

External Start/Stop button is on the control panel as membrane button. It generates start and stop. Set the applying range of it.



START/STOP

1	Only Shaker	The button only works for shaker's start/stop.
2	Only Incubator	The button only works for incubator's start/stop.
3	Shaker Incubator	The button only works for shaker and incubator's start/stop.

NOTICE

- Shaker and incubator are both available for the external membrane button. Once one of the shaker/incubator is on the generating and touch the button, the stopped part is operated. Touch the button again, both of mode are stopped.

4.4.3 Calibration

The temperature sensor and rpm reached to the user's reference measure value, accurate experiment circumstance can be made. Calibration for coordinate is available.

4.4.3.1 Temperature Calibration

Calibration for temperature sensor of main controller. The unit provides three points calibration. Each point of three shows the uncalibrated and calibrated status. Touch the point you want to change. Touch the one point of Calibration 1,2,3. Put the external sensor on the chamber and close the door.

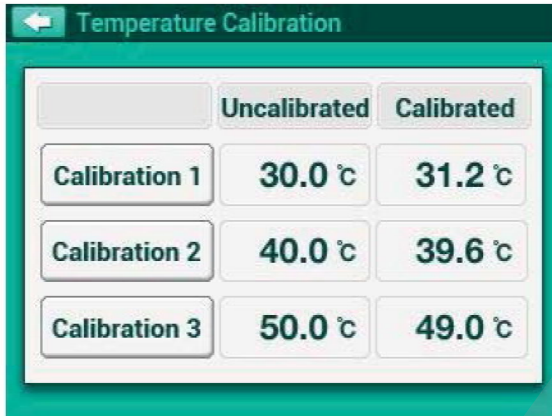

	Uncalibrated	Calibrated
Calibration 1	30.0 °C	31.2 °C
Calibration 2	40.0 °C	39.6 °C
Calibration 3	50.0 °C	49.0 °C

Touch the temperature on Set Temp. and put the desired temperature on it and operate the unit. Wait until the actual temp reaches to the setting temp. Once the actual temp reaches to the setting temp, touch the calibrated temp and put the temperature from the external sensor. Touch the confirm for the saving. The unit stops the operating. The unit read the temp as the external sensor's value.

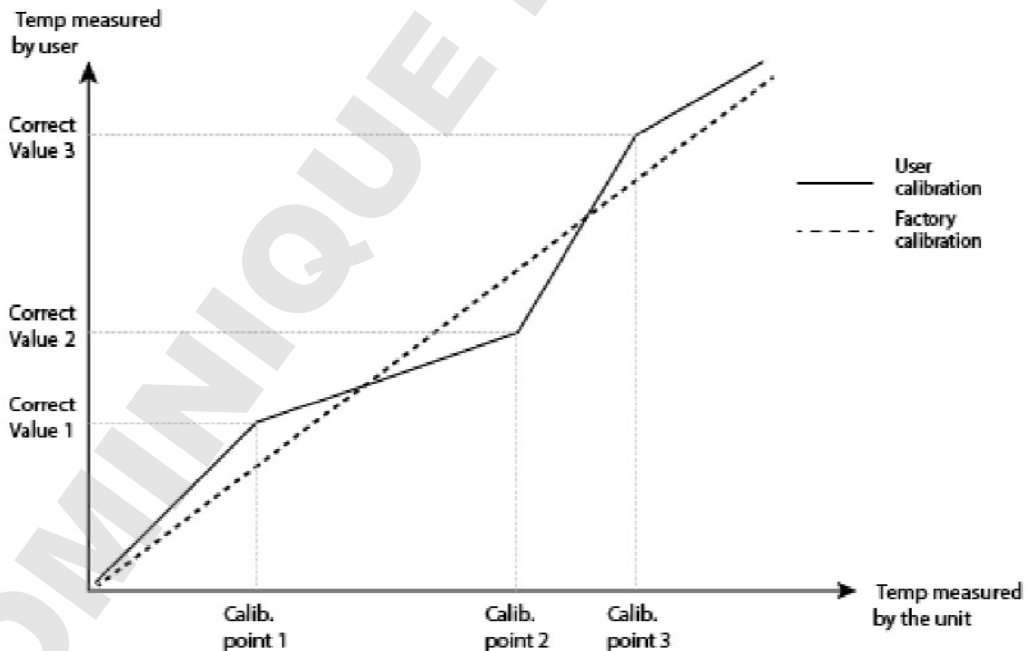

NOTICE

- Once the door is opened or the temperature is out of range, the temperature control is stopped.
- The calibration is operating on various points so it limits the calibrating that is out of the logic.
- The result of the calibration is on the uncalibrated and calibrated. Uncalibrated means the value from the unit and the calibrated means the temp that calibrated. The calibrated value is from the external sensor.
- The calibration setting is available to be initialized on the System Setting Reset.

4.4.3.2 Shaking Speed Calibration

The user calibrates the unit's rpm with external sensor. The unit is available for one point rpm calibration. The procedure is similar with temperature calibration. The difference is that the shaking is not stopped during the door opening because the door need to be opened to check the shaking with external sensor. Touch the set rpm. Put the desired rpm and start the nut. Wait until the actual rpm reached to the set rpm. Touch the calibrated rpm and put the value from the external sensor. Touch the confirm button to save it. The unit read the calibrated value from the next operating.

NOTICE

- Be careful that the external sensor never touch the platform. Once the external sensor is removed from the platform during the operating, it will be dangerous.
- The calibration setting is available to be initialized on the System Setting Reset.

4.4.3.3 Touch Screen Calibration

Touch penal coordinate could be in the problem for the reason of the older unit and the problem in the unit. The unit has a touch screen coordinate function. Touch the "+" on the screen three time s. And repeat it two times.

4.4.4 Auto Tuning

Update the parameter of PID temperature control. Optimum temperature for the main using temperature is available. The unit is set to use the temperature on proper range. Once the temperature is not actual on the main points during the actual use on the field, operating auto tuning will tune the temperature parameter and make the unit operates the temperature on the actual temperature. Touch the Set Temp. and put the desired value. Touch the START button and start the parameter tuning. Touch the stop button during the tuning and stop the tuning. Once the tuning is complicated, touch the ok button and save it.

4.4.5 Operating Parameters

Set the parameters for the other operating.

1	Position Sensor	Check the platform stop on the right position.
2	Stall Check	Check the belt when the platform is not working properly.
3	Defrost Use	Defrost is not for the IST model. Off the defrost use.
4	Load Unbalance	Once the vibration is generated, the shaking speed is adjustable.
5	Threshold	Load Unbalance check the vibration on the unit and adjust the

		rpm automatically. The vibration is on the range of not controlling, the automatic adjusting is operated.
--	--	---

4.4.6 Reset

Initialize the changed value to the factory value.

1	Temperature Calibration	Initialize the calibration value.
2	RPM Calibration	Initialize the calibration value.
3	Auto Tuning	Initialize the calibration value.
4	Touch Screen	Initialize the calibration value.
5	Operating Parameters	Initialize the calibration value.
6	Factory Default	Initialize the calibration value of all parts.

NOTICE

- Auto tuning parameter can be initialized to the factory value.

4.5 Safety Tool

4.5.1 Over Temp. Limiter

This model has the over temp limit and temp sensor in the main controller. Over temp limit is located on the right down side of the unit. Set the over temp limit over 15% than normal use temperature by a flat head screwdriver. In case of that the temperature in the chamber over set temp, the operation discontinues.

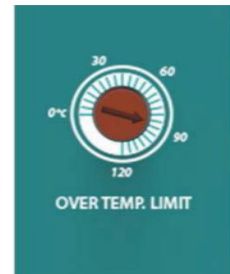

4.5.2 High/Low Temp. Limiter

This model has electric High/Low Temp. Limiter additionally. Over Temp. limiter is operated mechanically. But Electric High/Low Temp. Limiter make operation stop by receiving high/low value from user. If PV is out of high/low value, it is supposed to be stopped. Please refer to Appendix 9.2 regarding how to use electric High/Low Temp. Limiter



4.5.3 Glass Fuse

In the case of the over current generating, the fuse is cut and the power is down.

5 Maintenance

5.1 Inspection Period

Classification	Inspection period				
	Daily	Weekly	Monthly	Quarterly	Yearly
General					
Power					
Connection between machine and power	•				
Power code	•				
Exterior cleanliness		•			
Drain connection				•	
Outside refrigeration system connection (ISS-3075/ISS-4075)				•	
Incubator					
Set temperature and actual temperature difference	•				
Auto Tuning				•	
Temperature setting					
Temperature correction					•
Actual temp. / Display temp. correction					•
Air filter clean (ISS-3075R/ISS-4075R)			•		
PC Sync operation	•				
Controller and timer operation				•	
System					
Connection between platform and accessories	•				
Connection between platform and shaking table	•				
Actual rpm/ Display rpm correction					•
Malfunction of shaking system			•		

5.2 Cleaning

- (1) After disconnect the power cord, clean the machine with soft and dried towel.
Regarding the un-removable point, clean the polluted area only by towel with alcohol solvent (methanol, ethanol) which has low boiling point.
- (2) Do not use Acid solution, sharp one, soapy water, detergent and hot water.
It makes the machine discolored. Rubber and plastic part can be change of shape and color.
Especially, do not use volatile matter.
In case of neutral detergent, clean it with the soft fabric and dry well.
- (3) Do not put the water to exterior of the machine when you clean the surrounding (Especially, socket and controller part, it can make short circuit problem.)
- (4) After discussion the proper cleaning method to avoid any damage for the machine with Jeitech, if you want to clean the machine or remove the polluted area with not mentioned cleaning method before the clean.
- (5) The inside electric part of the machine should be handled by Jeitech or person who is delegated by Jeitech.
- (6) If the parts is required to replace, please use genuine parts only.
- (7) Technical maintenance is not offered in case of abnormal trouble beyond the normal limit.

WARNING



- Do not soak the machine into water and spray the water.

CAUTION



- Do not clean whole body with chlorine bleaching, detergent with chlorine, an abrasive, ammonia, steel sponge and alcohol solvent (methanol, ethanol) which has low boiling point.
-

5.3 Air filter cleaning (ISS-3075R/ISS-4075R)

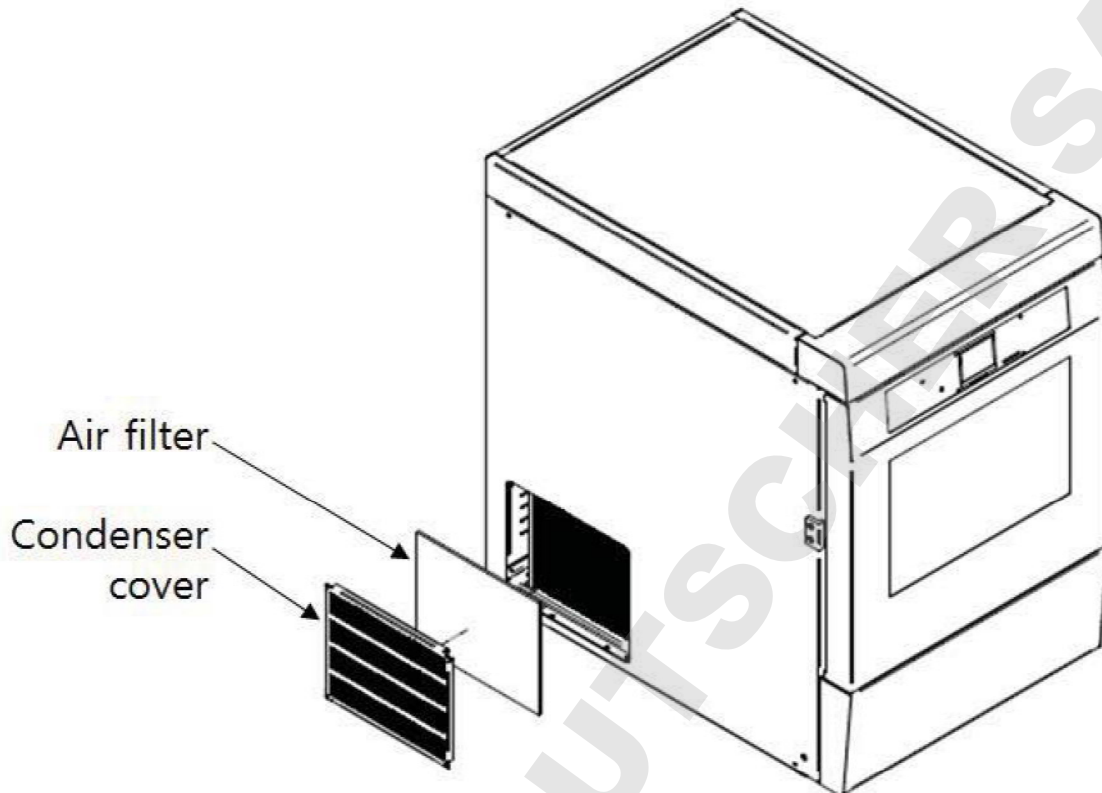

- Step 1: Put power switch and turn the machine off.
- Step 2: Loosen the bolt that located in edge of condenser cover
- Step 3: Disassemble condenser cover
- Step 4: Disassemble air filter which is combined with condenser cover.
- Step 5: Vacuum or clean the air filter with the water.
- Step 6: Vacuum or high pressure air clean to the condenser in the machine.
It makes better refrigeration effect.
- Step 7: Assemble air filter in reverse order of Step 1~Step4

NOTICE

- When air filter clean, please be careful to avoid fold the condenser pin, It is possible to decrease refrigeration effect.
-

5.4 Fuse Replacement

Replace the fuse which is located in next to power button (Refer to 2.3) if no operation of short circuit breaker and No power. There is extra fuse 2pcs in socket case inside. If you need additional fuse, ask it to sales team or seller.

Model	Voltage	Current consumption(A)	Fuse (A)	Fust Cat. No.
ISS-3075	120VAC, 60Hz	9.9	15	00CDE0005541
	230VAC, 50/60Hz	5.2	10	00CDE0005543
ISS-4075	120VAC, 60Hz	9.9	15	00CDE0005541
	230VAC, 50/60Hz	5.2	10	00CDE0005543
ISS-3075R	120VAC, 60Hz	13.5	15	00CDE0005541
	230VAC, 50/60Hz	7	10	00CDE0005543
ISS-4075R	120VAC, 60Hz	14.7	15	00CDE0005541
	230VAC, 50/60Hz	7.6	10	00CDE0005543

Fuse is located in next to power switch. (Side of machine.)

Please replace the fuse according the below picture.

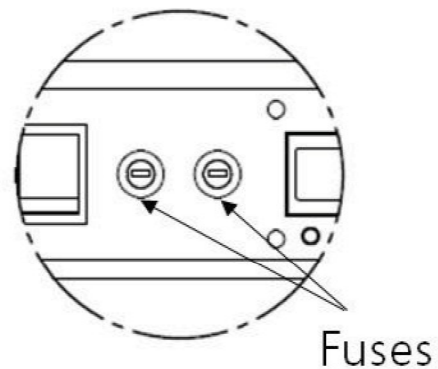
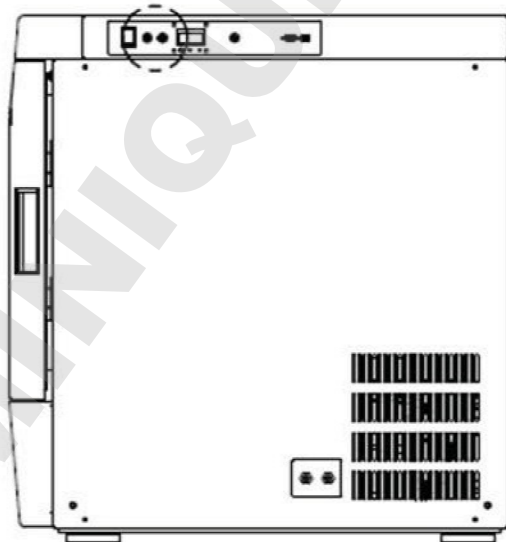

⚠ WARNING**Caution to Electrical shock.**

Before replace the fuse, turn the machine off and check the power connection again.

If the power is connected, serious injury or death can be occurred.

Step 1: Press power switch and Power off

Step 2: Connect (-) screw driver to fuse holder
Spin the fuse holder counterclock wise 50 ° then fuse holder is disassembled.

Step 3: Compare the fuse specification with the above table and replace it if there is no problem.

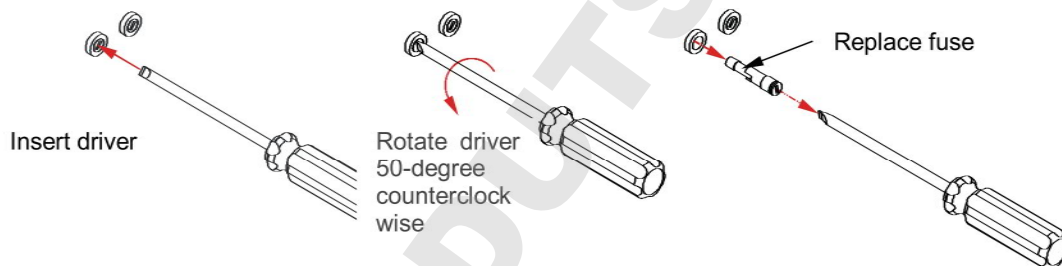

Step 4: Complete the replacement in reverse order of Step 2

6 Troubleshooting

6.1 Stop during the operating

Display Message	Description	Solution
Temperature Limit	Analog over temperature regulator is active.	Check the set on the analog over temperature regulator and the operating. Restart after temperature is inside of the range.
Load Unbalance	Vibration is generating and the normal shaking is not available. To prevent the shaking system, stop the shaking.	Check the unbalanced sample setting, overload, un-flat ground.
Door Open	Door is opened over 5 minutes during the operating.	Close the door and touch the start button and restart the unit.
Sensor Fault	Temperature sensor is faulty so the operating is stopped.	Contact the manufacturer or sales point.
Over Current	Over current is generated so the operating is stopped.	Check the overload, obstacle in the shaking system.

6.2 Another problem and solution

Trouble	Probable Cause & Solution
<p>The equipment is not on</p>	<ul style="list-style-type: none"> ① Check the power plug connection to the socket ② Check if the circuit breaker is operated ③ When the fuse is short circuited, replace new one as enclosed. ④ Check the power failure ⑤ If the problem is not fixed with the above method, please request A/S
<p>Power on but controller does not operated</p>	<ul style="list-style-type: none"> ① Check the power plug connection to the socket ② Check the panel board circuit breaker and reset it then turn the machine on. ③ Request A/S if Display board or Main PCB has problem. ④ Request A/S if Power switch has problem.
<p>NO The temperature of incubator rise to setting value</p>	<ul style="list-style-type: none"> ① Check the Temperature Control ON indicator is ON ② Check outdoor temperature is too high or low and maintain the right room temperature. ③ Request A/S after check the difference between actual temperature and display temperature. ④ Check the door switch irregularity ⑤ Request A/S if the heater is out of order ⑥ Request A/S if the freezer is out of order. ⑦ Check air filter condition and clean it according to 5.3 ⑧ Auto tuning if the temperature is unstable according to 4.4.4. ⑨ If the problem is not fixed with the above method, please request A/S.
<p>Shaking trouble</p>	<ul style="list-style-type: none"> ① If there is extremely intense vibration of the machine than usual during operation, check the horizontality. If you need, please adjust horizontality according 3.4.2 ② If there is extremely intense vibration of the machine and shaking speed is slow down, check the sample location and relocate the samples harmoniously ③ In case of overloading, control the sample weight according to 9.1(Max load per speed).

	<ul style="list-style-type: none">④ Check door switch if shaking is not operated after shaking start button press.⑤ Check Timer close status if shaking is not operated after shaking start button press, cancel timer set-up.⑥ If the problem is not fixed with the above method, please request A/S.
Noise	<ul style="list-style-type: none">① Check fixed condition of platform or sample.② Check the weight of sample is shifted to one side, relocate the samples evenly.③ If the problem is not fixed with the above method, please request A/S.

7 Accessories

7.1 Mountable maximum quantity

7.1.1 Universal Platform + Flask Clamp

Model Flask Clamp	ISS-3075 series	ISS-4075 series	Cat.No.
50ml	36	49	AAA23550
100ml	24	39	AAA23551
250/300ml	14	24	AAA23552/AAA23556
500ml	9	16	AAA23553
1,000ml	6	9	AAA23554
2,000ml	4	6	AAA23555
2,800ml	2	5	-
4L	-	4	AAA23558
6L	-	2	AAA23559

7.1.2 Universal Platform + Plastic Flask Clamp

Model Type	ISS-3075 series	ISS-4075 series	Cat.No.
50ml	36	49	AAA30570
100/125ml	19	29	AAA30571
200ml	13	21	AAA30572
250ml	13	19	AAA30573
300ml	12	19	AAA30574
500ml	9	12	AAA30575
1,000ml	4	9	AAA30576
2,000ml	2	5	AAA30577

7.1.3 Universal Platform + Funnel Clamp

Model Funnel Clamp	ISS-3075 series	ISS-4075 series	Cat.No.
250ml	4	6	AAA23562

500ml	3	4	AAA23563
1,000ml	-	3	AAA23564

7.1.4 Universal Platform + Microplate Holder

Type \ Model	ISS-3075 series	ISS-4075 series	Cat.No.
Single	8	15	AAA23654
Tower	6	10	AAA23651
Flat A(large)	-	2	AAA23562
Flat B(small)	2	3	AAA23563

7.1.5 Universal Platform + Test Tube Rack

Type \ Model	ISS-3075 series	ISS-4075 series	Cat.No.
Ø8mm(86ea)	2	4	AAA23581
Ø10mm(86ea)	2	4	AAA23582
Ø12mm(58ea)	2	4	AAA23583
Ø14mm(58ea)	2	4	AAA23584
Ø17mm(32ea)	2	4	AAA23585
Ø25mm(19ea)	2	4	AAA23586
Ø35mm(10ea)	2	4	AAA23594

7.1.6 Spring Wire Rack +Flask

Type \ Model	ISS-3075 series	ISS-4075 series
Cat.No.	AAA31521-VI	AAA231522-VI
50ml	16	25
100/125ml	9	16
250/300ml	4	9
500ml	4	5
1,000ml	2	4

2,000ml	1	2
2,800ml	1	2

7.1.7 Dedicated Platforms

Description	Cat.No.
An universal platform for ISS-3075/R Models with 250mL flask clamps 13ea	AAA31551
An universal platform for ISS-3075/R Models with 500mL flask clamps 10ea	AAA31552
An universal platform for ISS-4075/R Models with 250mL flask clamps 24ea	AAA31561
An universal platform for ISS-4075/R Models with 500mL flask clamps 16ea	AAA31562

7.1.8 Rubber Mats

Model Type	ISS-3075 series	ISS-4075 series
	Cat.No.	AAA31531

7.1.9 Universal Attachment

Models	ISS-3075/R	ISS-4075/R
Cat. No.	AAA31511	AAA31512

7.1.10 Lab Sticker

Description	Size	Cat.No.
Size (mm / inch, W×D×H)	200×200×5 / 7.9×7.9×0.2	AAA30551

7.1.11 Wire Shelves

Models	Description		Size	Cat.No.
	Included	Maximum		
ISS-3075/R	2	8	416×406/ 16.4×16	EDA8235
ISS-4075/R	2	11	516×506/ 20.3×19.9	EDA8233

※ About the right position for mounting maximum quantity of Accessories, please visit Jeio Tech website or contact our office and distributor..

8.0 S/W

8.1 Monitoring Program installation

- (1) Put the installation CD on the CD-ROM drive then the program is operated automatically. Click the “Next” button go to the License Agreement.



- (2) Check the details and click the “I agree”

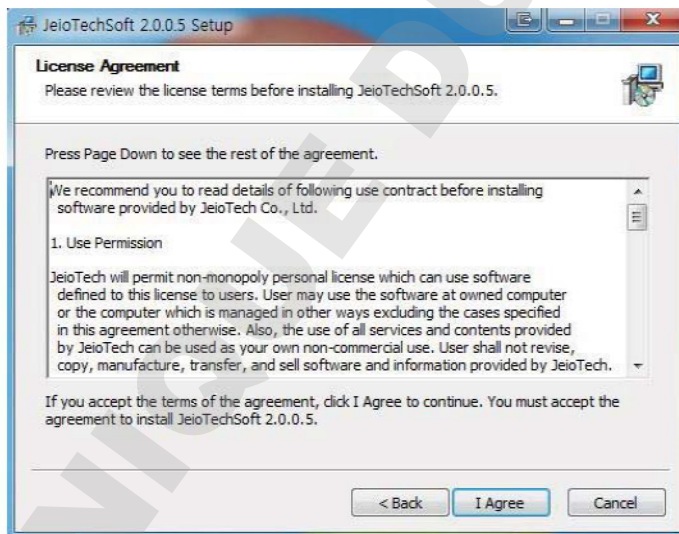

- (3) Click the “Install” and install the program.

Choose Install Location

Choose the folder in which to install JeioTechSoft 2.0.0.5.



Destination Folder

C:\Program Files (x86)\JEIOTECH\JeioTechSoft Browse...

Space required: 21.9MB
Space available: 49.0GB

< Back Install Cancel

- (4) Once the program is installed, below window is up and JeioTechSoft icon is generated on the background.
Check the Run JeioTechSoft 2.0.0.5 or double click the icon then the program starts.



8.2 Communication Protocol

The unit communicates with PC through RS-232C port. Software save the duplex communication, operating status, date. If you want to change on software, refer to below reference.

Communication Reference :

http://www.modbus.org/docs/Modbus_Application_Protocol_V1_1b3.pdf

8.2.1 Physical Layer

- Communication port : RS-232C /USB

8.2.2 Model System number

ITEM	System Number	System	Model Number
Incubated Shaker	1621H	Shaking incubator	ISS-3075
	1622H	Shaking incubator	ISS-3075R
	1623H	Shaking incubator	ISS-4075
	1624H	Shaking incubator	ISS-4075R

8.2.3 Modbus Protocol Address Definition

modbus function code	address	command	data	description	data length	
					word	byte
W/S	1	Beep	0x0001	BEEP_SYS_BOOT (Communication Test)	1	2
			0x0002	BEEP_KEY (Communication Test)	1	2
R/I	2	MOD_SYS_NAME	x	Model name	1	2
R/I	3	MOD_SYS_VERSION	x	Firmware Version	1	2
R/I	4	MOD_SYS_PARAMETER	x	system parameter	20	40
W/S, R/I	25	MOD_SYS_SOUND	0/1	system sound	1	2
W/S, R/I	26	MOD_SYS_LAMP	1 ~ 3	lamp bright	1	2
W/S, R/I	27	MOD_SYS_LAMP_AUTO	0/1	lamp auto onoff	1	2
W/S, R/I	28	MOD_AUTO_RESTART	0/1	system auto restart	1	2
W/M, R/I	29	MOD_TEMP_DEVI	temp devi min ~ temp devi max	temperature deviation	4	8
W/S, R/I	33	MOD_TEMP_DEVI_ALARM	0 ~ 3599	temp devi alarm time	1	2
W/S, R/I	34	MOD_RPM_DEVI	rpm devi min ~ rpm devi max	rpm deviation	1	2
W/S, R/I	35	MOD_RPM_DEVI_ALARM	0 ~ 3599	rpm devi alarm time	1	2
W/S, R/I	36	MOD_EXT_KEY	0 ~ 2	external key operation	1	2

		Y				
W/M, R/I	37	MOD_SET_TEMP	low temp lmt ~ high temp lmt	incubator set temp	4	8
W/S, R/I	41	MOD_SET_RPM	rpm min ~ rpm max	shaker set rpm	1	2
W/M, R/I	42	MOD_SHAKER_TIME	60L ~ 3599940L	shaker set time	2	4
W/S	44	MOD_SHAKER_TIME_ONOFF	0 ~ 1	shaker timer set	1	2
W/S	45	MOD_INCUBATOR_RUN_STOP	0 ~ 1	incubator operation set	1	2
W/S	46	MOD_SHAKER_RUN_STOP	0 ~ 1	shaker operation set	1	2
R/I	47	MOD_SYS_REPORT	X	system report	18	36
W/S	65	MOD_WARN_ACK	1	system warning ack	1	2
W/S	66	MOD_SILENT_ACK	1	system silent ack	1	2
W/S	67	MOD_AUTO_ACK	1	auto run ack	1	2

8.2.4 Modbus Protocol Description

Command	Description	Modbus function code	0						
Beep	Beep generating	W.S	Data	Write data	1	System boot beep			
				2	System key beep				
MOD_SYS_NAME	Return the unit name Refer to System number	Modbus function code	0	Return data	0				
		R.I	address		Upper	Lower	Model num		
MOD_SYS_VER	Return the firmware version	Modbus function code	0	Return data	0				
		R.I	address		Upper	Lower	version		
MOD_SYS_VER	Return the system parameter	Modbus function code	0	Return data	0 ~ 3	4 ~ 7	8 ~ 11	12 ~ 15	
		R.I	address		high temp lmt	low temp lmt	temp_d evi_max	temp_d evi_min	
					16	17	18	19	
					max rpm	min rpm	rpm_d evi_max	rpm_d evi_min	
MOD_SYS_SOUND	Set the system sound	modbus function code	0	return data	0				
		R.I	address		upper	lower	sound flag		
		modbus function code	0	r/w data	0	sound off			
		W.S	data		1	sound on			
MOD_SYS_LAMP	Set the lamp brightness	modbus function code	0	return data	0				
		R.I	address		upper	lower	lamp bright		
		modbus function code	0	r/w data	1 ~ 3				
		W.S	data		1 : Min, 3 : Max				
MOD_SYS_LAMP_AUTO	Automatic lamp on setting	modbus function code	0	return data	0				
		R.I	addresses		upper	lower	lamp auto flag		
		modbus function code	0	r/w data	0	lamp auto off			
		W.S	data		1	lamp auto on			
MOD_AUTO_RESTART	Auto run setting	modbus function code	0	return data	0				

		R.I	addresses		upper	lower
					auto run flag	
		modbus function code	0	r/w data	0	auto run off
		W.S	data		1	auto run on

MOD_TEMP_DEVI	temperature deviation	modbus function code	0	return data	0 ~ 3	
		R.I	addresses		temp devi	
		modbus function code	0~3	value	temp devi min ~ max	
		W.M	value			

MOD_TEMP_DEVI_ALARM	temp devi alarm time	modbus function code	0	return data	0	
		R.I	addresses		temp devi alarm	
		modbus function code	0	value	0 ~ 3599(sec)	
		W.S	value			

MOD_RPM_DEVI	rpm deviation	modbus function code	0	return data	0	
		R.I	addresses		rpm devi	
		modbus function code	0	value	rpm devi min ~ max	
		W.S	value			

MOD_RPM_DEVI_ALARM	rpm devi alarm time	modbus function code	0	return data	0	
		R.I	addresses		rpm devi alarm	
		modbus function code	0	value	0 ~ 3599(sec)	
		W.S	value			

MOD_EXT_KEY	external key operation	modbus function code	0	return data	0		
		R.I	address		ext key value		
		modbus function code	0	value	0	1	2
		W.S	value		shaker	incubator	both

MOD_SET_TEMP	incubator set temp	modbus function code	0	return data	0 ~ 3	
		R.I	addresses		set temp	
		modbus function code	0 ~ 3	value	high temp ~ low temp	
		W.M	value			

MOD_SET_RPM	shaker set rpm	modbus function code	0	return data	0	
		R.I	addresses		set rpm	
		modbus function code	0	value	rpm min ~ max	
		W.S	value			

MOD_SHAKER_TIME	shaker set time	modbus function code	0	return data	0 ~ 1	
		R.I	addresses		set time	
		modbus function code	0 ~ 1	value	0 ~ 3599940L(1min)	
		W.M	value			

MOD_SHAKER_TIME_ON OFF	shaker timer on/off set	modbus function code	0	data	0 : shaker timer off
		W.S	data		1 : shaker timer on

MOD_INCUBATOR_RUN_STOP	incubator operation set	modbus function code	0	data	0 : incubator stop
		W.S	data		1 : incubator start

MOD_SHAKER_RUN_STOP	incubator operation set	modbus function code	0	data	0 : shaker stop
		W.S	data		1 : shaker start

MOD_SYS_REPORT	system report	modbus function code	0	return data	0 ~ 3	4 ~ 7	8	9
		R.I	address		set temp	act temp	set rpm	act rpm
					10 ~ 11	12 ~ 13	14 ~ 15	16 ~ 17
					set time	remain time	system indicate	dummy

system indicate	4byte	MSB	30	29	28	27	26	25	24
		dummy	dummy	dummy	dummy	usb_mode	temp delay	auto tune	sk over cur

					0 : report 1: slave	무시할 것.			
		23	22	21	20	19	18	17	16
		rpm hold	temp hold	silent	ext otp	sk load warn	sk load	rpm devi	temp devi
		15	14	13	12	11	10	9	8
		auto run	mute	refrig	sens or	opt warn	door warn	otp	door open
					error				
		7	6	5	4	3	2	1	LSB
		usb connec t	silent disp	sk pos er	lamp	timer	shaker	incubat or	operation
					on/of f	on/off	op_flag	op_flag	sys op

MOD_WARN_ACK	warn message clear	modbus function code	0	data	1: message clear
		W.S	data		0: operation none

MOD_SILENT_ACK	mute	modbus function code	0	data	1: beep stop
		W.S	data		0: operation none

MOD_AUTO_ACK	auto run ack	modbus function code	0	data	1: auto run clear
		W.S	data		0: operation none

9.0 Appendix

9.1 Technical Specifications

MODEL		ISS-3075	ISS-3075R	ISS-4075	ISS-4075R
Temperature	Range(°C/°F)	Amb.+5to80/ Amb.+9to176	Amb.-20 (Min. +4)to80/ Amb.-36(Min. +7.2)to176	Amb.+5to80/ Amb.+9to176	Amb.-20 (Min. +4)to80/ Amb.-36(Min. +7.2)to176
	Accuracy(±°C/°F)	±0.1/0.18 in flask at 37°C			
	Uniformity(±°C/°F)	±0.5/0.90 in flask at 37°C			
	Refrigerator (Hp)	-	1/6Hp,HBP	-	1/6Hp,HBP
	Sensor Type	Pt 100Ω			
Shaking	Motion	Orbital			
	Amplitude Size (mm, dia.)	19.1/0.75			
	Speed Range (RPM)	10 to 500 (Stacking 10 to 250)			
	Accuracy	±1% of set speed (>100rpm) / ±1 (<100rpm)			
	Timer	1 min. to 999 hr 59 min.			
	Max. Load (kg/lbs)	10/22.0 at 500 rpm 21/46.3 at 400 rpm			
Material	Internal	Stainless Steel			
	External	Epoxy powder coated steel			
	Platform	Anodized aluminum plate			
	Insulation	EPDM 25t			
	Door	Insulating Glass 21t			
	Heater	Incoloy, Fin Type (550W X 2EA = 1,100W)			
Safety Device		CLS(Custom Logical Safe)-control system			
		Electronic temperature limiter, Hydraulic over-temperature limiter			
		Temperature deviation alarm (High/Low)			
Communication Interface		USB, RS232			
Dimension	Volume (L/cu ft)	80/2.8		150/5.3	
	Platform (W×D) (mm/inch)	350×350/13.8×13.8		450×450/17.7×17.7	
	Internal (W×D×H) (mm/inch)	440×440×418/17.3×17.3×16.5		540×540×518/21.3×21.3×20.4	
	Overall (W×D×H) (mm/inch)	578 x 815×854/22.4×32.1×33.6		678 x 895×934/26.7×35.2×38.8	
	Net Weight (Kg/lbs)	153/337.3	160/352.7	183/403.4	190/418.9
Electric requirements (230V/50/60Hz)		5.2	7	5.2	7.6
Electric requirements(120V/60Hz)		9.9	13.5	9.9	14.7

9.2 How to use High/Low Temp. Limit

As the standard (the temperature of NTC sensor), Circuit switch is off when out of limit of High/Low temperature.

Basic display : showing allowed High temp (H), allowed Low temp (L).

H : 112 °C

L : 0 °C

Checking current temperature by Up/Down.

Actual PV : XX

Stand by over 10sec or, back to basic display by SET button.

Status indicator color changes from Green to Orange when current temp is out of allowed temp range.

And if this status (out of allowed temp) keep going >

- 1) Indicator color is changed to Red.
- 2) Protect HIGH.T(High temp)/LTP(Low temp) shows up.
- 3) Thermostat connect to temp limiter will be off.

After checking the matters, back to basic display by Up/Down and SET button simultaneously.

It is available to set the range of limit (H/L temp) in Parameter setting display (press SET button over 2sec in Basic display)

LOW. T <-> HIGH T. <-> Unit

Checking parameter value by SET button and set the value by Up/Down.

High Limit : -10 ~ High Limit (C')

Low Limit : Low Limit ~ 120 (C')

Stand by over 5 sec or, back to basic display by SET button.

Revise the temperature as below, when current temperature is not matched with displaying temperature.

Turn off first,

Press Set button, Up/Down button at the same time and then turn on.

After pressing Set button, Up/Down button for 4sec, all set will be initialized and OFFSET will be showed up.

And press SET button to set OFFSET value.

Adjust OFFSET value (-10~10 'C) by Up/Down button, and press SET to save.

Check the revised OFFSET (saved) value after reset.

9.3 Disposing of products

Before you dispose product or the components



1. The equipment should be cleaned and decontaminated to protect workers servicing the equipment, the environment or the public purchasing surplus equipment because the incubated shaker can potentially be contaminated with biological material, chemicals or radioisotopes. Check with your institution or laboratory for individual policies and procedures for disposal of laboratory equipment.

2. Please contact your local governing body for regulations regarding disposal of electrical, electronic, metal (brass, aluminum, steel and stainless steel), refrigeration and rubber components. Jeio Tech recommends the user find a local scavenger or laboratory equipment recycler to properly dispose of the unit and its components.

9.4 Warranty

9.4.1 Terms of Warranty Service

(1) Customer can get free warranty service for 2 years limited warranty from the date of shipping date when the machine is broken while operating.

(2) When you ask for repairing, please check the below details first.

- Date of purchase
- Customer name / address / Phone number / E-mail
- Fault status

9.4.2 Warranty exception

Customer can't get free warranty service in case of as below.

- If the product is broken due to the user's fault.
- If the product is broken due to improper operation or storage.
- If the product is broken due to improper modify or repairing.
- If the product is broken due to overuse of voltage or earthshock.
- If the product is broken without taking care of the "Notice" alerted on the manual.

9.4.3 Service and technical advice

We, Jeiotech Co., Ltd. are doing best to give best support based on customer service system.

When we get the symptoms, fault states, contact number by customer, we offer after sales service.

➤ **International Sales Head Office (Korea)**

#1005, Byucksan Digital Valley 6-cha, 219, Gasan digital 1-ro, Geumcheon-gu, Seoul,
Korea
153-704

Tel: +82 2 2627 3816 **E-mail:** overseas@jeiotech.com

FAX: +82 2 3143 1824

➤ **The Americas (U.S.A. Branch)**

19 Alexander RD Unit #7, Billerica MA 01821, U.S.A.

Tel: +1 781 376 0700 **E-mail:** info@jeiotech.com

FAX: +1 781 376 0704

➤ **Europe (U.K. Branch)**

Unit 3, Tower Business Park, Warpsgrove Lane, Chalgrove, Oxfordshire, OX44 7XZ, United
Kingdom

Tel: +44 1865 400321 **E-mail:** labcompanion@medlinescientific.com

FAX: +44 1865 400736

➤ **China (Shanghai Branch)**

B-705, Jingting Bldg. No.1000 Hongquan Rd, Minhang district,

Shanghai, P.R.CHINA 201103

Tel: +86-21-5108-9161, 5414-8389 **E-mail:** longjuncao@jeiotech.com

FAX: +86-21-5168-5414

➤ **South East Asia (Malaysia Branch)**

No 57-59, Jalan Adenium 2G/6, Pusat Perniagaan Adenium, 48300 Bandar Bukit
Beruntung, Selangor Darul Ehsan , Malaysia

Tel: +60 3 6021 6880 **E-mail:** labcompsea@gmail.com

FAX: +60 3 6021 7880

- | |
|---|
| <ul style="list-style-type: none">• The contents of this manual can be changed or upgraded without prior notice.• The copyright of this manual is reserved by Jeio Tech. |
|---|