

Series	2100 Series 200 µl Universal Tip		
Part Number	2100, 2100.N	2107, 2107.N 2107.S	2102.N, 2102.NS, 2102, 2102.S
Graduation Marks	Graduation marks are indicated at 10 µl, 50 µl and 100 µl locations – refer to product image for visuals		
Tip Color	Clear		
Tip Composition	Neptune pipette tips are made of virgin polypropylene		
Tip Types Available	Natural Polypropylene and S ³ *		
Filter Material	Non-filtered products		
Offered in Pre-Sterile Format	No	Yes	
Configuration	Bulk	ESP Reload**	Racked
Packaging Breakdown	1000 tips per bag 10 bags per case	96 tips per card 10 cards per pack 10 packs per case	96 tips per bag 10 cards per pack 5 packs per case
Autoclavable	Autoclavable at 120 °C for 10-15 minutes at 15 PSI		
Storage Conditions	Store in a clean, dry environment at room temperature 15-30 °C		

2100 Series

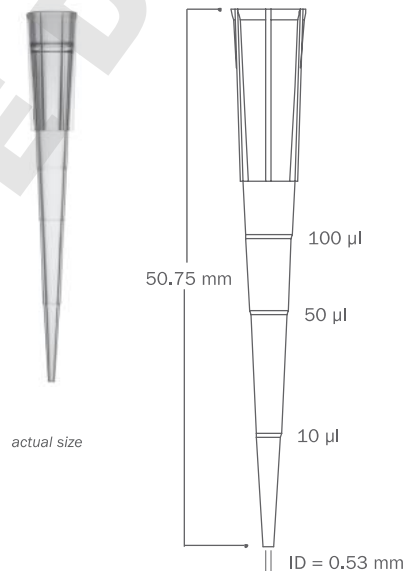

S³* Sample Saving Surface virtually eliminates sample hold-up
ESP Reload** Neptune's patented reload system
 Environmentally Sustainable Pack (ESP) reduces plastic waste by up to 90%





Quality Control

Certificates of Compliance	Each lot undergoes stringent inspection and individual lot testing ensures Neptune products are certified RNase, DNase, DNA and Endotoxin-free. Visit www.neptunescientific.com to obtain a copy of a certificate of compliance for your Neptune product.
RNase/DNase	Products are washed in distilled water and concentrated via centrifugation. Samples are added to previously established nucleic acid standards, incubated for one hour at 37°C, and tested on a 2% gel using electrophoresis. Products must show no degradation of standards to pass. Test sensitivity is 10 ⁻⁷ Kunitz units/μl.
Nucleic Acid	Products are washed in distilled water and concentrated via centrifugation. Then, samples are added to protocol specified PCR reactions and thermal cycled for 50 cycles. A 2% agarose gel electrophoresis is used to examine experimental samples, positive controls, and negative controls. To pass, product samples must show no DNA amplification. Test sensitivity is 10 ng.
Endotoxin/Pyrogen	Products are tested for endotoxins by using the Limulus Amebocyte Lysate (LAL) gel assay according to FDA guidelines. Test sensitivity is 0.06 EU/ml.
Sterilization	Products are sterilized using electron beam irradiation.
Traceability	Each product contains a 5 digit lot number located on the rack, pack and case of each finished good. With Neptune's advanced manufacturing process all raw materials are able to be traced for maximum quality assurance.

Advancements in Liquid Handling

S ³	Neptune's exclusive S ³ polymer was designed to increase pipetting accuracy by virtually eliminating tip retention and sample hold-up.
ESP Reload	Neptune's ESP (Environmentally Sustainable Pack) was the industry's first pipette reload system designed to minimize plastic waste by 90% and provide an environmentally friendly solution.
Aerosol Barrier Tip	Specifically engineered to reduce cross contamination.
Rack & Stack	192 tips per rack; 5 racks per unit. For high volume and multi-channel users.

Pipettor Compatibility:

Biohit™ M100 and M200

Biohit Proline Plus™ 100 μl and 200 μl

Brand Transferpette S™ 20 μl, 100 μl and 200 μl

Brand Transferpette Electronic™ 300 μl

Capp™ 50 μl, 100 μl and 300 μl

CLP Beta-Pette™ 20 μl, 100 μl and 200 μl

CLP Poseidon™ 50 μl, 100 μl, 200 μl and 300 μl

CLP Poseidon Electronic™ 200 μl

Eppendorf Reference™ 20 μl, 100 μl and 200 μl

Eppendorf Research™ 20 μl, 100 μl, 200 μl and 300 μl

Eppendorf Research Plus™ 20 μl and 100 μl

Eppendorf Xplorer™ 20 μl and 100 μl

Finnpipette™ 20 μl, 50 μl, 200 μl and 300 μl

Finnpipette™ Electronic 300 μl

Gilson Pipetman™ P20, P100 and P200

Gilson Pipetman Ultra™ U20 and U200

www.neptunescientific.com

NEPTUNE
Tools for Life Sciences