

Series	BT10XL Series 10 µl Extended Length Barrier Tip		2340 Series 10 µl Extended Length Tip		
Part Number	BT10XL	BT10XLS3	2340	2347.N 2347.NS	2342 2342.S
Graduation Marks	Graduation marks are indicated at both 2 µl and 10 µl locations – refer to product image for visuals				
Tip Composition	Neptune pipette tips are made of virgin polypropylene				
Tip Type	Natural Polypropylene	S ³ *	Natural Polypropylene		
Filter Material	High Density Polyethylene Filter		Non-filtered products		
Configuration	Racked		Bulk	ESP Reload**	Racked
Packaging Breakdown	96 tips per rack 10 racks per pack 5 packs per case		1000 tips per bag 20 bags per case	96 tips per card 10 cards per pack 5 packs per case	96 tips per rack 10 racks per pack 5 packs per case
Autoclavable	No		Autoclavable at 120° C for 10-15 minutes at 15 PSI		
Storage Conditions	Store in a clean, dry environment at room temperature 15-30				
Offered in Sterile Format	Yes		No	Yes	

BT10XL Series

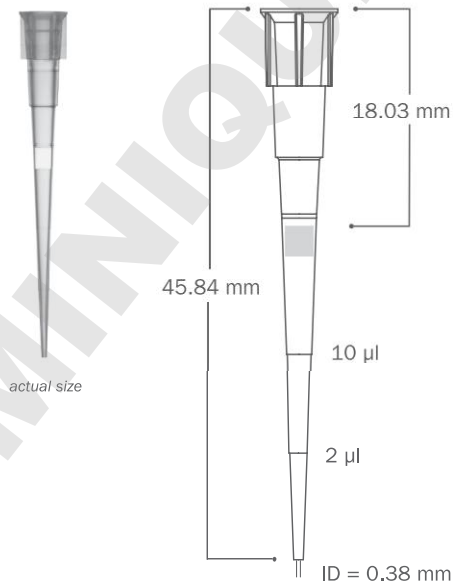

2340 Series

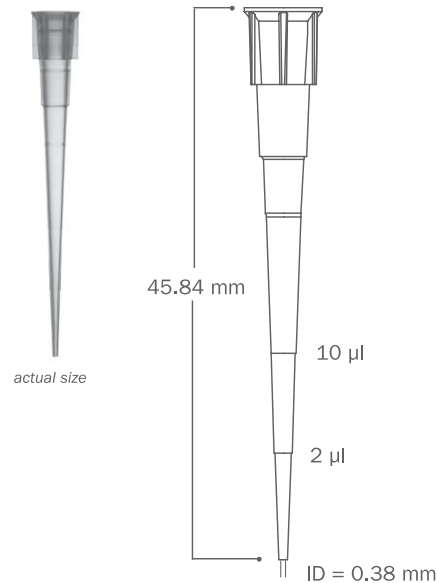

S³* Sample Saving Surface virtually eliminates sample hold-up
ESP Reload** Neptune's patented reload system
 Environmentally Sustainable Pack (ESP) reduces plastic waste by up to 90%





Quality Control:

Certificates of Compliance	Each lot undergoes stringent inspection and individual lot testing ensures Neptune products are certified RNase, DNase, DNA and Endotoxin-free. Visit www.neptunescientific.com to obtain a copy of a certificate of compliance for your Neptune product.
RNase/ DNase	Products are washed in distilled water and concentrated via centrifugation. Samples are added to previously established nucleic acid standards, incubated for one hour at 37°C, and tested on a 2% agarose gel using electrophoresis. Products must show no degradation of standards to pass. Test sensitivity is 10 ⁻⁷ Kunitz units/μl.
Nucleic Acid	Products are washed in distilled water and concentrated via centrifugation. Then, samples are added to protocol specified PCR reactions and thermal cycled for 50 cycles. A 2% agarose gel electrophoresis is used to examine experimental samples, positive controls, and negative controls. To pass, product samples must show no DNA amplification. Test sensitivity is 10 ng.
Endotoxin/ Pyrogen	Products are tested for endotoxins by using the Limulus Amebocyte Lysate (LAL) gel assay according to FDA guidelines. Test sensitivity is 0.06 EU/ml.
Sterilization	Products are sterilized using electron beam irradiation.
Traceability	Each product contains a 5 digit lot number located on the rack, pack and case of each finished good. With Neptune's advanced manufacturing process all raw materials are able to be traced for maximum quality assurance.

Advancements in Liquid Handling:

S ³	Neptune's exclusive S ³ polymer was designed to increase pipetting accuracy by virtually eliminating tip retention and sample hold-up.
ESP Reload	Neptune's ESP (Environmental Sustainable Pack) was the industry's first pipette reload system designed to minimize plastic waste by 90% and provide an environmentally friendly solution.
Aerosol Barrier Tip	Specifically engineered to reduce cross contamination.

Pipettor Compatibility:

Biohit Proline™ 10 μl
 Brand Transferpette S™ 10 μl
 Capp™ 10 μl
 CLP Beta-Pette™ 2 μl and 10 ul
 CLP Poseidon™ 2 μl and 10 ul
 CLP Poseidon Electronic™ 20 μl
 Eppendorf Reference™ 2.5 μl and 10 μl

Eppendorf Research™ 2.5 μl and 10 μl
 Eppendorf Research Plus™ 2.5 μl and 10 μl
 Eppendorf Xplorer™ 10 μl
 Finnpiette™ 10 μl and 50 μl
 Finnpiette™ Electronic 10 μl
 Finnpiette F1™ 10 μl
 Gilson Pipetman™ P2 and P10

Hamilton™ 2 μl and 10 μl
 Nichiryo Nichipet EX™ 10 μl
 Nichiryo Oxford Benchmate™ 2 μl
 Nichiryo Oxford Multimatch™ 10 μl
 Socorex Calibri 822™ 10 μl
 VWR Ultra High Performance™
 2 μl and 10 μl