

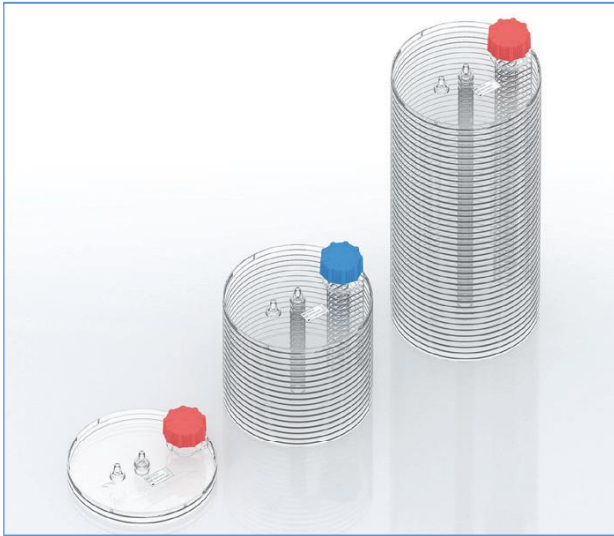

## Instructions for Use

### CELLdisc™ - Multi Layer Device (1 - 40 Layers)



The Greiner Bio-One CELLdisc™ is a ready-to-start, multi layer device, as easy to use as a T-flask. The innovative ergonomic CELLdisc™ design provides a versatile system for the propagation of adherent mammalian cells from research scale to industrial batches. It is available either with the standard tissue culture surface (TC; red screw cap) or the Advanced TC™ surface (blue screw cap) identical to all Greiner Bio-One cell culture products to assure consistent performance from lot to lot and from format to format.

The single layer CELLdisc™ (CD1), in contrast to the larger multi layered versions, allows easy monitoring of cell growth, cell morphology and confluency. As conditions within the single layer CELLdisc™ will be identical to those within larger units, the CD1 can be used to anticipate when media

changes are required and harvesting is recommended in any larger units being cultivated alongside the CD1. To ensure that the ambient conditions for the reference CD1 and the multi layer CELLdisc™ are absolutely identical, the CELLlevator™ allows storage of the single layer CELLdisc™ on top of the CELLdisc™ production unit. To ensure safe usage in general, customers are advised to test Greiner Bio-One systems under the conditions defined in their own protocols.

## Intended Use

The product is a cell culture disposable to be used by trained personnel in a laboratory surrounding.

## General CELLdisc™ Details

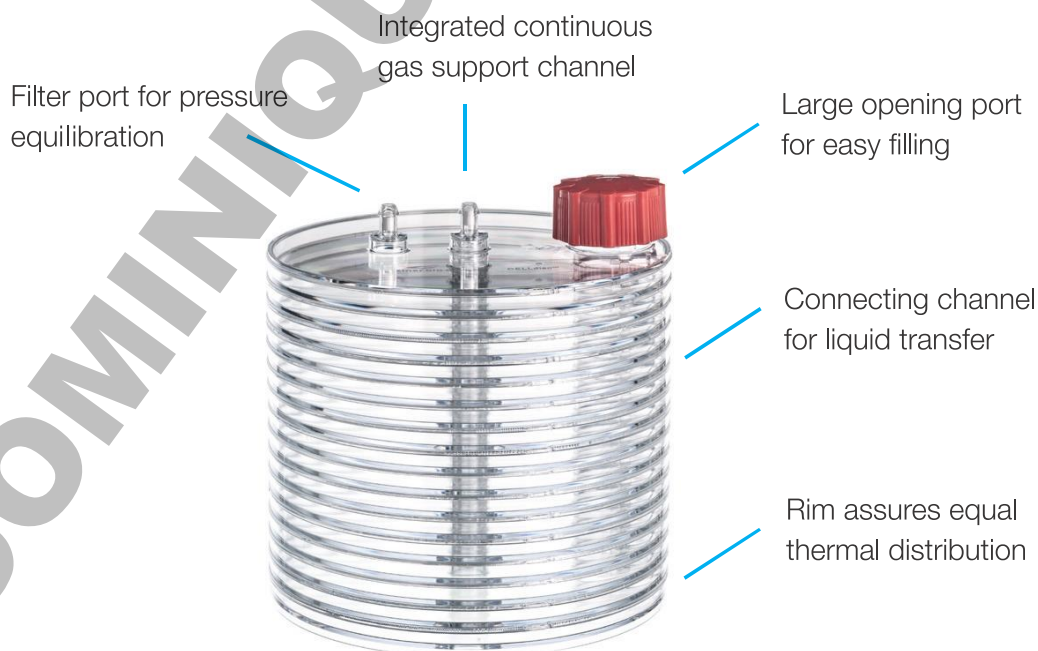

# Instructions for Use

## ① Single Layer CELLdisc™

1. Unpack the single layer CELLdisc™ and place it in a laminar air flow cabinet in order to work in sterile conditions.
2. Prepare cell suspension in accordance with the concentration (cells/cm<sup>2</sup>) used with other disposables for adherent cell culture. Unscrew screw cap and transfer the cell suspension directly into the CELLdisc™ using the large opening port either by pouring or pipetting (Fig. 1). Firmly tighten the screw cap onto the CELLdisc™ to close it.
3. Tilt the single layer CELLdisc™ gently from one side to the other to assure that media and cells distribute evenly.

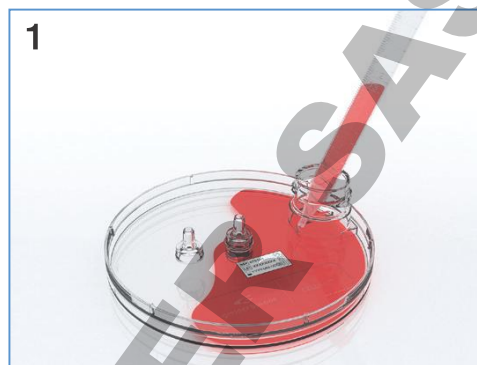

**Warning:** The media or cell suspension should **not touch the filter**. If the filter has absorbed any fluid, this will inhibit any gas transfer into and out of the CELLdisc. In this case the disposable has to be discarded and a new single layer CELLdisc™ has to be used.

## ② CELLdisc™ 4 - 24 Layers

**Note:** To obtain equivalent cell growth in all layers, formation of air bubbles must be avoided during CELLdisc™ processing. Therefore, an exact angle of 30° and a specific position of the central filling channel (see Fig. 2 and Fig. 3.1/ 3.2) must be maintained during filling of 4-, 8- and 16-layer CELLdisc™. This handling procedure guarantees that the pressure is equalized through the central gas channel (indicated in blue in Fig. 4) without contact with the filled in liquid. Thus, the air does not flow through the liquid and does not cause foaming. In addition to the filling process, any generation of air bubbles should be avoided. Vigorous shaking of the CELLdisc™ is not recommended. Larger volumes of liquids should be mixed outside the CELLdisc™ and then added to the disposable as described below. Small amounts can be pipetted directly into the CELLdisc™ and then distributed to all layers by repeating the equilibration process.

1. Unpack the CELLdisc™ and place it in a laminar air flow cabinet in order to work in sterile conditions.
2. Prepare cell suspension in accordance with the concentration (cells/cm<sup>2</sup>) used with other disposables for adherent cell culture.
3. Hold the CELLdisc™ at an **angle of 30°** (Fig. 2) with the screw cap at a position of approximately 105° for right-handed users (Fig. 3.1) or 255° for left-handed ones (Fig. 3.2). Unscrew screw cap and add the cell suspension either by pouring or pipetting directly into the CELLdisc™ using the large opening port as indicated in Fig. 4. The media will fill the topmost layer first and then move slowly to each layer underneath.



Wait until the liquid is distributed into the individual layers still keeping the CELLdisc™ in the indicated position before firmly tighten the screw cap to close it (Fig. 5). To start liquid equilibration lay down CELLdisc™ horizontally and turn it as displayed in Fig. 6/ Fig. 7 to assure that the media and all layers are in contact through the central filling channel. The media will now separate equally between all layers (Fig. 8).

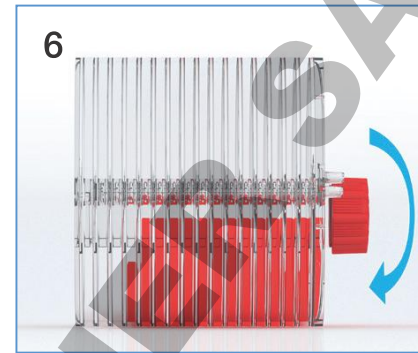
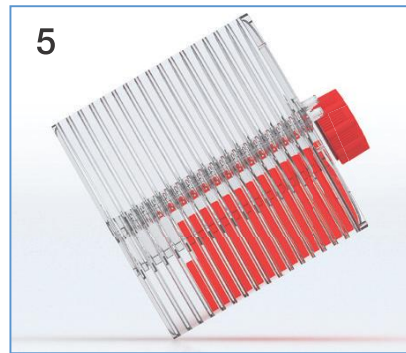
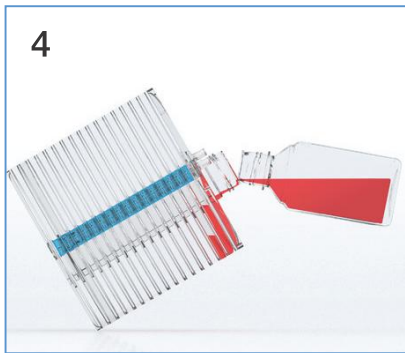

**Note:** Small volumes of liquids (e.g. trypsin) may accumulate in the upper layers during filling and not flow through the whole filling channel. To guarantee equal distribution the liquid must be in contact with all layers through the filling channel before the equilibration process is initiated. Therefore the CELLdisc™ must be positioned horizontally with the opening port at the lowest position.

- Turn the CELLdisc™ as indicated in Fig. 9 to disconnect media flow from the filling channel. Do not rotate the CELLdisc™ any further as this could lead to wetting of the filter.

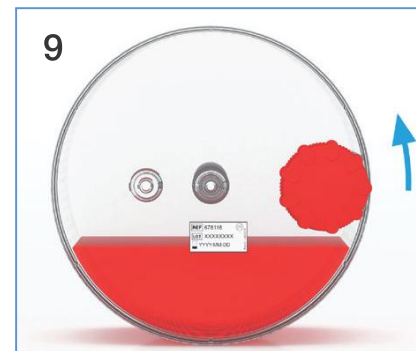
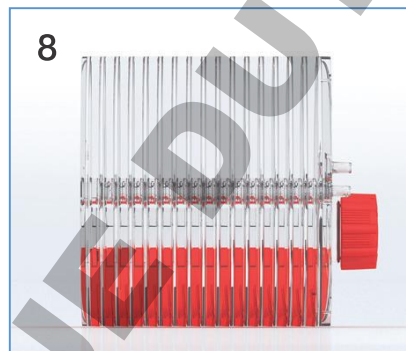
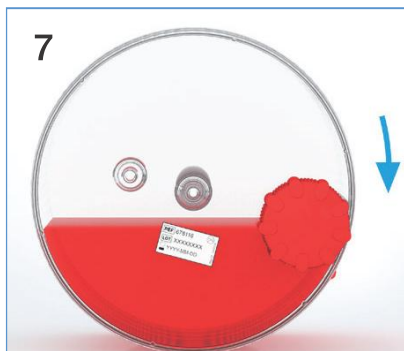

**Warning:** The media or cell suspension should **not touch the filter**. If the filter has absorbed any fluid, this will inhibit any gas transfer into and out of the CELLdisc™. In this case the disposable has to be discarded and a new CELLdisc™ has to be used.

- From this position raise the CELLdisc™ upright (Fig. 10) and place the disposable on a horizontal surface inside an incubator (Fig. 11). Proceed with the cultivation based on the appropriate protocol.



To stack individual CELLdisc™ or a single layer CELLdisc™ on top of a production CELLdisc™ use the CELLlevator™ (Fig. 12). More details on CELLlevator™ can be found on the reverse side.





**Note:** During transport, tilt the CELLdisc™ slightly backward to assure that there is no liquid contact with the filling channel or accidental media flow to another layer.

- For liquid removal, unscrew screw cap and tilt the CELLdisc™ slowly 90° with the large opening port at the lowest possible position and pour out the media or use a pipetting system as displayed in Fig. 13 and 14.

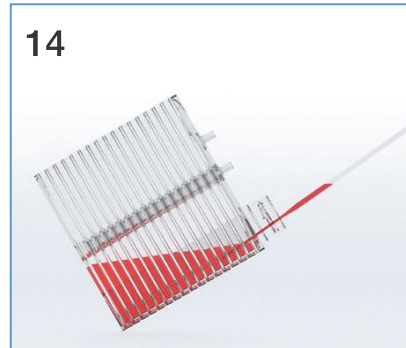
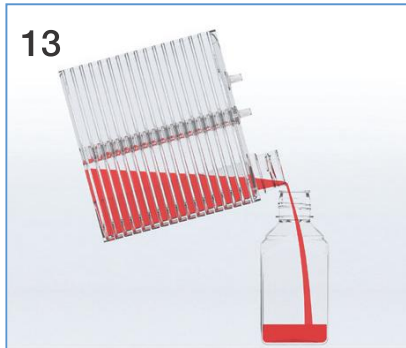

### ③ CELLdisc™ 40 Layers

- As with the CELLdisc™ 4-24 layers, air bubble formation must be avoided during processing to obtain even cell growth in all layers. While the position of the screw cap/filling channel and the general filling procedure is identical (Fig. 3.1/3.2) a smaller angle of 20° must be maintained during filling of a 40-layer CELLdisc™ (Fig. 15). This handling procedure guarantees that the pressure is equalized through the central gas channel (see Fig. 16, indicated in blue) without contact with the filled in liquid. Thus, the air does not flow through the liquid and does not create air bubbles.

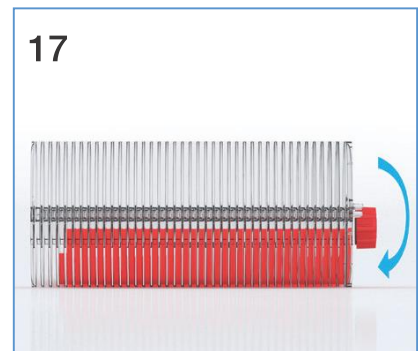
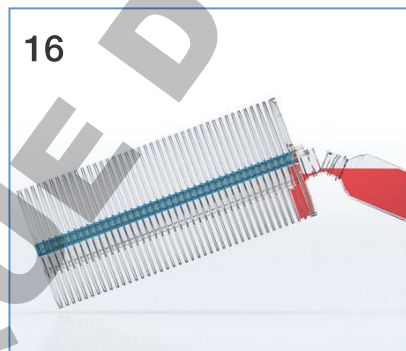
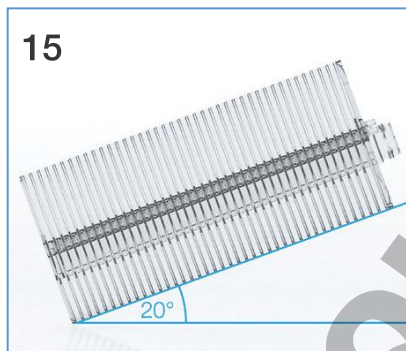

- To start liquid equilibration lay down the CELLdisc™ horizontally and turn it as displayed in figure 17 to assure that the media and all layers are in contact through the central filling channel. The media will now separate equally between all layers (Fig. 18). Turn the CELLdisc™ as indicated in Fig. 19 to disconnect media flow from the filling channel. From this position raise CELLdisc™ upright and place the disposable on a horizontal surface inside an incubator (Fig. 20).



- Liquid removal is identical to CELLdisc™ 4-24 layers (Fig. 13/14).

## ④ CELLdisc™ 4 - 40 Layers

### Harvesting of cells

The protocol for harvesting cells from a multilayer device such as CELLdisc™ which does not allow for direct pipette access varies slightly from your standard protocol. Especially as the detachment of cells can be visualized microscopically only for the bottom layer of a CELLdisc™ with one, four or maximum eight layers. This cell harvest protocol refers to standard techniques and specific suggestions to gain maximum cell yields.

In general, we recommend using the same dissociating solution and concentrations for enzymatic detachment that is used to harvest these cells from a standard Greiner Bio-One cell culture disposable. As the surface treatments and basic materials are identical for these vessels, standard protocols can be converted. The only adaption required is based on growth area and cell numbers per layer. The use of chelating agents such as EDTA in addition to the enzyme (trypsin, papain etc.) may improve cellular detachment. Remove cultivation media either by pouring or aspiration as described above. Wash cells once with PBS or an equivalent buffer using approx. 20 ml per layer. Follow the same protocol as for CELLdisc™ filling to distribute the buffer through all layers. Then tilt the CELLdisc™ slowly back and forth to gently rinse each cell layer and remove all traces of media.

Remove PBS either by pouring or aspiration. Thereafter add 7-10 ml of your enzymatic dissociation agent per layer. For a 4-layer CELLdisc™ this results in 28-40 ml which has to be equilibrated as described above. Incubate CELLdisc™ at 37 °C and 5 % CO<sub>2</sub> for 3-5 minutes. Tapping CELLdisc™ from the side can accelerate cellular detachment. Strong adherent cells might need longer incubation or stronger tapping. Stop the enzymatic reaction by adding the same amount of serum-containing media or an appropriate inhibitor to the CELLdisc™, equilibrate the liquids and mix the solutions by gently tilting the CELLdisc™ back and forth. Thereafter cell suspension can be harvested for further processing by pouring or aspiration.

If removal of the enzymatic dissociation agent is desired, then spin cell suspension at 100xg for 5 minutes. Remove the dissociation agent containing media and resuspend cell pellet in fresh media.

### CELLdisc™ Product Overview

Order no.	Layers	Surface treatment	Surface [cm <sup>2</sup> ]	Min working volume [ml]	Max working volume [ml]	Quantity per bag/case
678101	1	TC	250	15	70	1 / 8
678104/ 678904	4	TC/ Adv. TC	1.000	60	280	1 / 4
678108/ 678908	8	TC/ Adv. TC	2.000	120	560	1 / 3
678112/ 678912	12	TC/ Adv.	3.000	180	840	1 / 2
678116/ 678916	16	TC/ Adv. TC	4.000	240	1.120	1 / 2
678124/ 678924	24	TC/ Adv. TC	6.000	360	1.680	1 / 2
678140/ 678940	40	TC/ Adv. TC	10.000	600	2.800	1 / 1

CELLdisc™ is also available **with external filter, triple packed**: 678XXX-EXF.  
For further information please contact your local subsidiary or GBO distributor.

# CELLdisc™ Accessories



**CELLlevator™**  
Stacking device for CELLdisc™

Order no. 878071

Easy and secured CELLdisc™ stacking  
CELLlevator™ is positioned within the circumferential rim of the top plate of the CELLdisc™. Another CELLdisc™ can be positioned on top of the CELLlevator™.

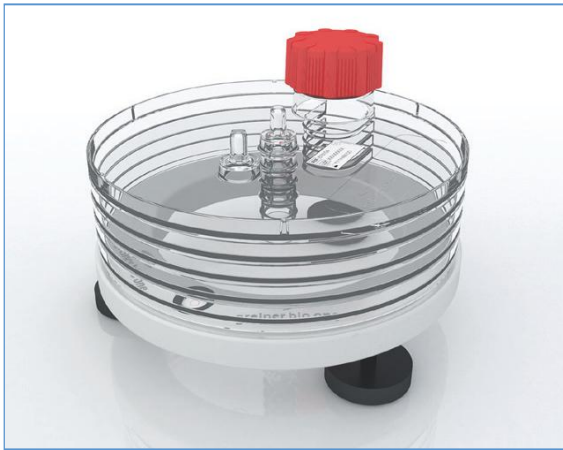

**CELLring™**  
Levelling ring

Order no. 878075

CELLring™ assures an exact horizontal position of CELLdisc™ compensating surface irregularities, e.g. of a working bench or an incubator.



**CELLhandle™**  
Gripping device

Order no. 878074

CELLhandle™ facilitates secure and easy transportation of particularly large-sized CELLdisc™ formats as well as convenient emptying of these.



A video animation showing the handling of CELLdisc™ is available on our website:  
[www.gbo.com/celldisc](http://www.gbo.com/celldisc)

For further information please visit our website [www.gbo.com](http://www.gbo.com) or contact us.

**Greiner Bio-One:**

<b>Austria</b> office@at.gbo.com	<b>Belgium</b> info@be.gbo.com	<b>Brazil</b> office@br.gbo.com	<b>China</b> office@cn.gbo.com	<b>France</b> accueil@gbo.com	<b>Germany</b> info@de.gbo.com	<b>Hungary</b> office@hu.gbo.com
<b>Italy</b> office@it.gbo.com	<b>Japan</b> info@jp.gbo.com	<b>Netherlands</b> info@nl.gbo.com	<b>Portugal</b> info@vacuette.pt	<b>Spain</b> info@es.gbo.com	<b>UK</b> info@uk.gbo.com	<b>USA</b> office@us.gbo.com