

Rif./Ref	Data/Date	Descrizione modifica / Modification	Disegnatore / Designer
E	02/07/2020	AGGIORNATO TOLLERANZA Ø FILETTO E RIFERIMENTO DISEGNO IN1096 IN TABELLA Thread diameter tolerance and reference IN1096 on list updated AGGIORNATO CARTIGLIO E INSERITO TABELLA LINER / Datasheet updated and liner list inserted	Z.M.



TABELLA DEI LINER / LINER REF.

RIF.	CODICE	DESCRIZIONE	Ø	SP.	gr.	NOTE
A	YGR/PE2	LINER POLESPAN PE2	25.4	1.2	0.25*	*TO ADD TOTAL WEIGHT
B	YGR/205-28RP	LINER SAFE GARD PLUS/N	25.55	1.2	0.45*	*TO ADD TOTAL WEIGHT

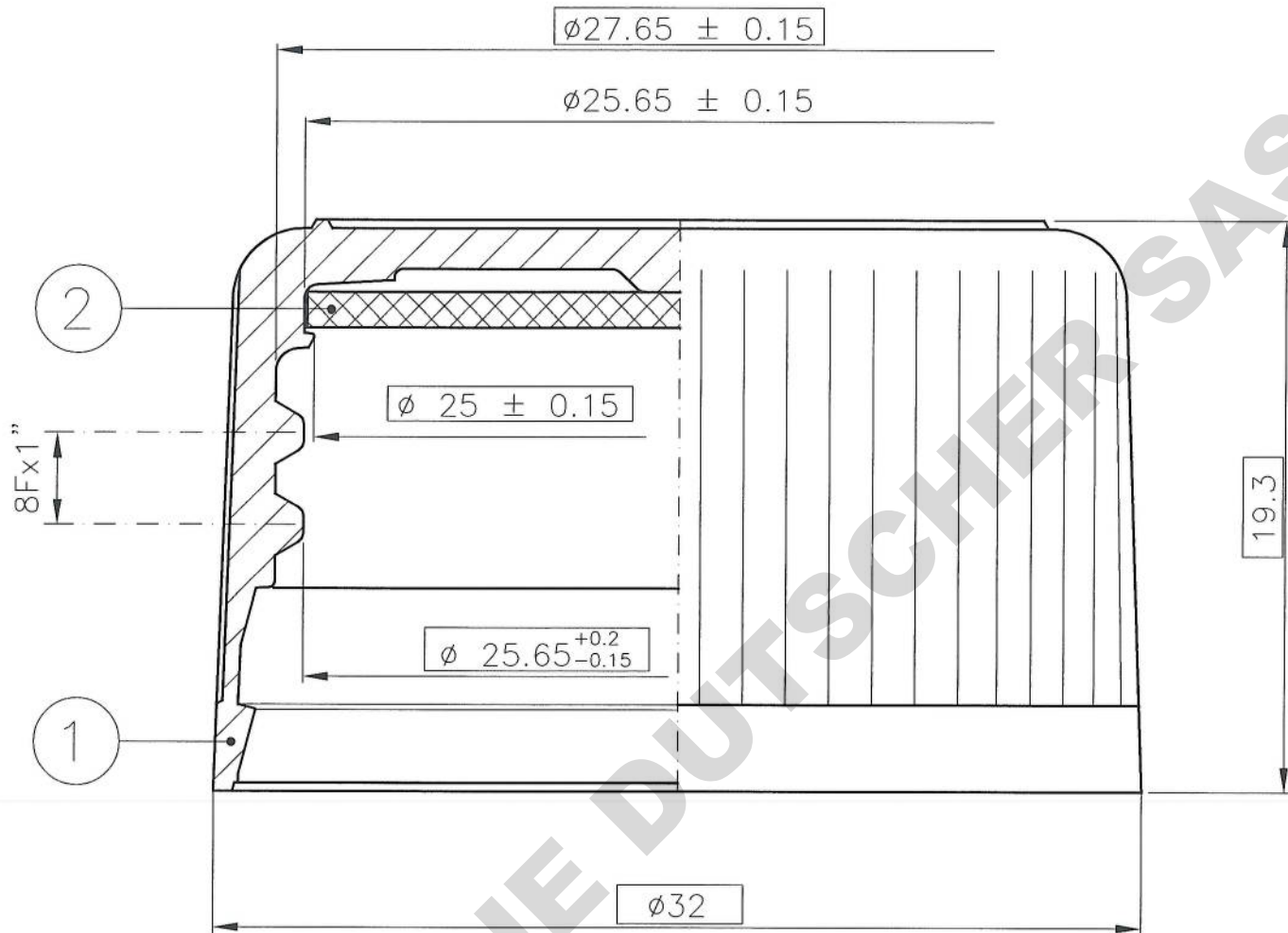

2	GUARNIZIONE / LINER	---	*	---	Vedi tabella / See ref.
1	CAPSULA T.E.28 / T.E. 28 CAP	PP	3.0 ± 0.3	IN 1096	Disegno / Drawing n° A2261/H
Pos./Pos.	Particolare/Component	Mat./ Mat.	Peso(gr.)/Weight	Articolo/Ref.	Note/Notes

Denominazione/ Description		Clientel/Customer						
COMPLESSIVO TE 28 x LINER TOTAL DRAWING TE 28 LINER		STANDARD						
Cap. Nom. ml. Nom. capacity	--	Cap. RB. ml. Brimful cap.	-- ± --	Prima emissione / First issue Dis.da / Designer	M.PEDRONA	Ultima rev. / Last rev. Appr. da / Approved by	Nota: le quote funzionali devono essere tassativamente verificate	
Peso Gr. Weight	3.0* ± 0.3	Toll. Gen. General Tol.	± 0.2	Data / Date	29/06/2005	Scala / Scale		4:1
Sostit. e Annulla Dis.N° Replace and delete drw N°	A4879/D	del issued	05/10/2018	Data / Date	29/06/2005	Data / Date	06/07/2020	
				Formato / Size	A4	Art. / Ref N°	AF4026	
				DisN/ Drw. N°	A4879		Rev. / Rev.	E
- NB : A NORMA DI LEGGE SI DIFFIDA DAL RIPRODURRE IL PRESENTE DISEGNO, O DI PASSARLO A TERZI - - In according to the law it is forbidden to reproduce the drawing or to pass it to third parts -				- QUOTE ESPRESSE IN mm - - dimensions in mm -				