

Operator's Manual



The Freedom Rocker™ BlotBot®

Congratulations!

Congratulations on your purchase of a Freedom Rocker™ BlotBot® by Next Advance, Inc. We're sure that once you use it, you will never want to process your Western blots manually again.

Please read this operator's manual which explains proper operation of the instrument. This manual is posted on our website, www.nextadvance.com. Click on the "Support" button and then on the appropriate link to the manual.

We're confident that your BlotBot will become an essential tool in your laboratory and we wish you success with your work.

Contents

Parts of the BlotBot.....	2
The BlotBot Work Area	3
Table of Icons	4
Setup.....	5
Operation.....	5
Programming the BlotBot.....	6
After the Run	7
Maintenance	7
Troubleshooting.....	9
Support.....	9
Specifications.....	10
Warranty.....	10
Warnings	11
Disclaimer	11
Contact Info.....	12

Parts of the BlotBot®

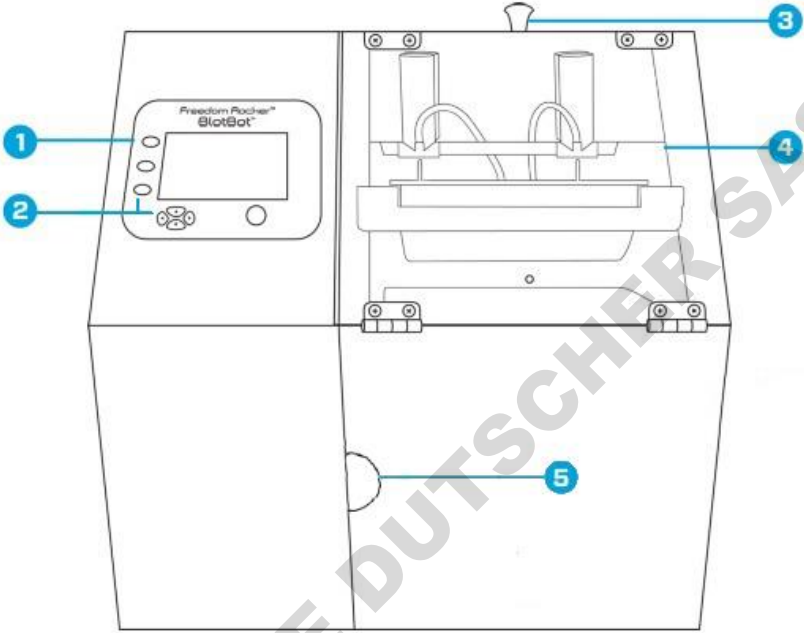

Model 120 shown. Model 240 has twice the work area.

- (1) Display (2) Control Buttons (3) Window Knob (4) Work Area visible through the window (5) Waste tank compartment



Caution: follow the instructions in the Operator's Manual



This product complies with European Low Voltage and EMC Directives



Please dispose of the tubes, trays, and BlotBot in accordance with local regulations

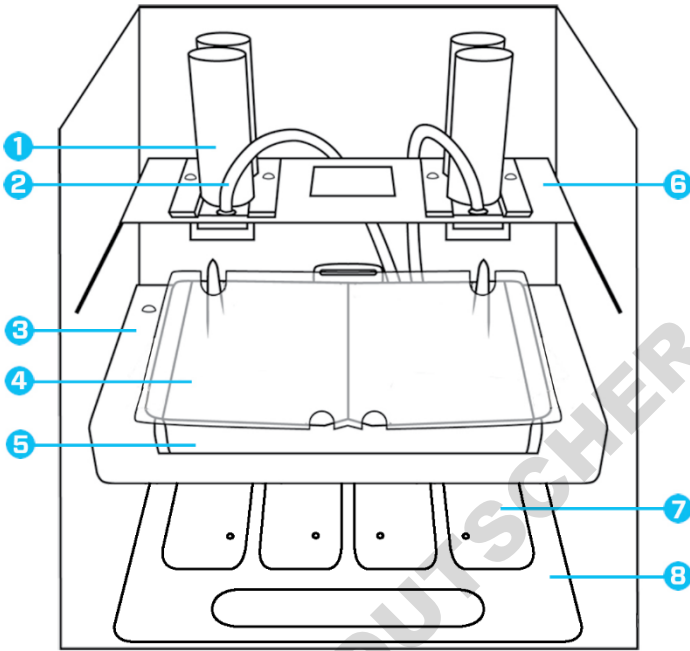











The BlotBot Work Area

- (1) Reagent (antibody) tubes (2) Wash buffer tubing (3) Rocker cradle
(4) Tray cover (5) Sample tray (6) Reagent slider
(7) Recovery funnel (8) Waste funnel (9) Funnel tray

Blots to be processed are placed in the sample tray. The mini blot tray, which has a central divider, can be used for mini blots and strips. Larger blots can be processed using the midi blot tray.

The reagent slider positions the reagent (antibody) tubes and the wash buffer nozzles over the sample tray when needed. Waste liquids are dumped into the waste funnel which directs them into the waste tank. Reagents that are to be recovered for reuse are directed into the recovery funnels.

The reagent tubes, tray cover, sample tray, funnel tray, and waste tank are easily removed from the machine for cleaning. Other components are designed to remain in the instrument.

Table of Icons			
	Accept		Fill
	Back		Home
	Cancel (Stop)		Pause
	Continue		Run
	Drain		Save
	Edit		

Button icons used on the BlotBot. The functions of particular buttons are explained in the text.

SETUP

Remove all tape and packing materials from the BlotBot, and place the BlotBot on a stable, level lab bench. Open the door and remove the funnel tray. Unscrew the caps from the 50 mL recovery tubes and place them in the holders to each side of the waste tank. Replace the funnel tray, with the arrow pointing toward the back of the unit. Slide it backward until it hooks into place. To check that it is in place, pull the funnel tray forward. It should have a little wiggle room but resist forward movement. Close the door.

Open the transparent window that protects the work area. Place the sample tray into the rocker cradle and push down to ensure that it is fully seated. If the sample tray is not seated properly then it will impair dispensing of the reagent. Place the tray cover onto the sample tray and make sure it is firmly held down by the magnets. See the "BlotBot Work Area" diagram for reference.

The wash buffer connector and the power jack are located at the back of the instrument. Attach the wash buffer hose to the connector, and attach the other end to the buffer bottle using the quick-connect fitting. Plug the power supply into the power jack on the back of the BlotBot, and insert the plug into a wall outlet. The machine is now set up.

OPERATION

Ensure that the window(s) and door(s) are completely closed. Turn the power switch on the back of the unit to the "on" position. The display will illuminate, and the moving parts will return to their home positions. After a few seconds, the home screen will display.

Program or select your preferred Western blot protocol (see "**Programming the BlotBot**", below).

Fill the buffer bottle. Ensure that the hose hanging from the cap reaches the bottom of the bottle. **Leave the cap loose** to allow air into the bottle as liquid is pumped out.

To fill the buffer hose, select "Flush" from the home screen menu, and press the "Accept" button. The reagent slider will move forward until the buffer dispensing nozzles are over the back of the sample tray. Press the "Fill" button until wash buffer is dispensed from both nozzles. (This may take several seconds.) When the tubing has been filled, press the "Drain" button to remove the dispensed buffer from the sample tray.

Check each reagent tube to make sure the foil seal is intact and firmly attached. If you are using primary and secondary antibodies, you will need two tubes for each blot you are processing. Screw one tube firmly and completely into the first reagent (e.g. primary antibody) position (toward the

back of the slider), and the other into the second reagent (e.g. secondary antibody) position, just behind the buffer dispensing nozzle.

Pour or pipet the desired reagent volume into each tube. A standard-sized mini blot processed in a mini blot tray requires a minimum of 3.5 mL of reagent, such as an antibody solution, per tube. The maximum is 50 mL.

Place your blot(s) into the sample tray **oriented with individual lanes aligned back to front**, along with your blocking solution or other starting reagent or buffer. If you are using a mini blot tray, which has a central divider, make sure the blot is on the same side of the divider as the appropriate reagent tubes, and use no more than 50 mL of blocking solution per side. (If you are using a midi blot tray, you may use up to 100 mL blocking solution.) Replace the tray cover and make sure it is fully seated.

Close the waste tray compartment and the work area window. Select the desired protocol from the menu, and press the "Run" button.

On the next screen, select the type of sample trays that will be used for the protocol. Follow the instructions on the screen to enable or disable individual compartments of the selected sample tray. Disabled compartments will not have buffer dispensed into them. When you are done, press the "Continue" button to proceed.

If you have not already done so, check the waste tank to make sure that it is empty, and place 50 mL tubes into the tube holders if you plan to recover reagent, such as antibody. Once this has been done, close the waste tray compartment and press the "Run" button to start the run.

PROGRAMMING THE BLOTBOT

The BlotBot is designed to work with your own laboratory protocols. This process starts at the home screen.

From the home screen, select "Programs". You will see a list of programs, which have been populated with default values as well as the option for "New Program".

Select one of the programs using the dial, and press the "Edit" button to begin editing the program. To program a new protocol, follow these steps:

Step 1: Choose a name for your protocol. Select letters and numbers by turning the dial. Use the cluster of four buttons at the lower left of the screen to navigate back and forth between characters, and to delete characters or add spaces. When finished, press the "Save" button to save your program name, and then press the "Continue" button to move to the next screen.

Step 2: On this screen, select whether the protocol will be used with a mini blot tray (2 chambers with a central divider), or a midi blot tray (one large

chamber). If you typically run mini blots, use the mini blot tray even if you plan to run only one blot at a time; it will save reagents. Press the "Save" button, and then press the "Continue" button to move to the next screen.

Step 3: Now, choose whether you want a clearing rinse to be included in the protocol. A clearing rinse will briefly rinse the blot with 10 mL of wash buffer at the end of each step. If you want a clearing rinse, highlight "Enable" on the screen and then press the "Save" button. Press the "Continue" button to continue.

Step 4: On the last screen, input the times and reagents for each step in your protocol. Buffer wash steps can be repeated up to 10 times, but reagent steps cannot be repeated. When selecting the reagent, you can choose the following: Buffer; Reagent 1; Reagent 2; or END. Selecting "END" indicates that there are no more steps. Note that you can select prefill for the first step. Since blots and gels should be kept wet, this first step takes into account any liquid, such as a blocking buffer, in the tray.

	REAGENT
STEP 1	Prefill
STEP 2	BUFFER
STEP 3	REAGENT 1
STEP 4	BUFFER
STEP 5	REAGENT 2
STEP 6	BUFFER
STEP 7	END

You should also indicate whether you want your reagent solutions to be recovered for future use. The BlotBot can recover up to two reagents. Recovered reagents will be diverted to the tubes held in the brackets on either side of the waste tank. If you do not plan to recover any reagents, you may set all reagent steps to "Waste" for the recovery option.

AFTER THE RUN

Once the run is complete, the tray will continue to rock at a slow speed with the last dispensed liquid, typically a wash buffer. Press the "Home" button to stop the rocker and return to the home screen. Open the window and remove the sample tray. The blot is now ready for downstream processing (chemiluminescent or colorimetric detection, etc.) The sample tray and cover can be washed using a gentle laboratory detergent. Use caution not to bend the spikes when washing the sample tray. Sample trays should never rest on the spikes. If a spike is bent, then reagent dispensing may be impaired.

Remove the reagent dispensing tubes from the machine. The BlotBot ships with a supply of reagent tubes; you may contact us or your local distributor for replacement tubes.

If you will not be using the BlotBot again for a few days, you may wish to flush the buffer line with distilled water. To do this, place the wash buffer hose into a container of water and use the "Flush" function to run water through the line and into the tray.

MAINTENANCE

General cleaning. Rinse the waste tank and funnel tray when desired. The components are made from reagents that are resistant to chemicals typically used in a Western blot, but some of the components of blocking buffers (nonfat dry milk, BSA, etc.) can form unattractive deposits on the surface.

If the instrument isn't going to be used for a while, clean it. If it is going to sit for more than 2 weeks, run distilled water through the lines. This will help prevent crystallization of salts or growth in the lines. This can be accomplished by changing the buffer bottle and holding down the "flush" button until you are satisfied.

The display screen protector, the work area window, and the interior surfaces of the BlotBot can be wiped down as needed with water and a laboratory wipe. Use of alcohol is not recommended, as it may fog some of the plastic surfaces over time.

Calibration. The pumps that deliver wash buffer to the tray have been calibrated at the factory. If you want to check or recalibrate the pumps, use the "Calibration" function to do so.

From the home screen, select "Maintenance". The on-screen instructions will guide you through the calibration process, which is described below. You will require a graduated cylinder (50 mL is ideal) to perform the calibration.

Before you calibrate the pumps, confirm that the wash buffer line is completely full of liquid. If there is air in the line, use the "Flush" function

(described above) to remove the trapped air.

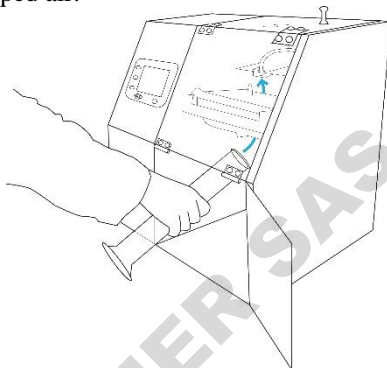

Open the waste compartment and remove the funnel tray. If you are using a larger graduated cylinder and need extra room, you may remove the waste tank as well.

Place the graduated cylinder under the buffer position indicated on the display, and press the "Fill" button to dispense liquid into the cylinder. The pump will dispense approximately 40 mL.

Once the pump has stopped running, measure the actual amount of liquid dispensed, and enter the value using the encoder knob. Measure the volume from the other positions the same way, and record the value. Press the "Save" button to save the values. The pumps are now calibrated. Replace the waste tank and funnel tray and close the waste compartment.

The BlotBot compensates for the effect of temperature on the volume of liquid dispensed by the pumps. Even so, it is better to calibrate the pumps near the ambient temperature at which it will be used. For example, if it will

be used in a cold room, calibrate the pumps in the cold room.

TROUBLESHOOTING

In addition to the tips given below, a list of troubleshooting tips is available at: nextadvance.com/blot_processor-support/.

If the BlotBot doesn't start, the plug of the power supply cord may not be in a live wall outlet or the power supply connector may not be fully inserted in the socket on the back of the BlotBot.

If the unit stops working, turn the system off for one minute to allow the electronics to reset. If the BlotBot does not turn on after this period, contact customer service.

If the unit stops during a run and displays an error message, the run will resume once the error is fixed. The most common error is that the work area window has not been fully closed.

If the unit has lost power because it was unplugged, or because there was a power outage, simply restore power to the unit when possible. If a run was in progress, it will automatically re-start at the point it had reached when power was lost. You do not need to take any special measures. If you wish to terminate the recovered run, simply press the "Home" button when the program recovery screen is displayed.

If the antibodies are not being dispensed, make sure that the sample tray is properly secured in the rocking cradle. Ensure that the spikes on the sample tray are facing toward the back of the instrument, and that they are still sharp. Make sure that the tray spikes

are not bent. The BlotBot ships with several trays. Replacement trays are available for purchase.

If buffer is not being dispensed during the run, check to make sure that the end of the buffer hose is resting in the bottom of a full bottle of buffer. The bottle cap should also be slightly loose in order to allow air to flow into the bottle.

If the buffer supply is adequate, use the "Flush" function to diagnose the difficulty. The pumps should be audible as soon as the "Fill" button is pressed; if they are not, call customer support. If the pumps are running but no liquid is dispensed, make sure the buffer nozzles have not become clogged with dried salts or detergent.

SUPPORT

FAQs and other helpful information can be found on our website, www.nextadvance.com. Click on the "BlotBot Automated Blot Processor" tab on the left hand menu. If you would like further assistance, contact customer service by email at customersupport@nextadvance.com or by telephone at 1.518.674.3510.

SPECIFICATIONS

	BlotBot 120	BlotBot 240
Width	37 cm (14-1/2 in.)	59.7 cm (23-1/2 in)
Depth	39 cm (15-1/4 in.)	40.7 cm (16 in)
Height	43 cm (17 in.)	44.5 cm (17-1/2 in)
Weight	12 kg (25 lb.)	15 kg (32 lb.)
Capacity		
Blots	2 mini blots or 1 midi blot	4 mini blots or 2 midi blots
Buffers	1	1
Buffer volume	Midi blot tray: 150 mL Mini blot tray 75 mL per side	
Reagents	dispense 2 recover 2	dispense 2 recover 2
Maximum reagent	50 mL each	50 mL each
Minimum reagent per blot	Midi blot tray: 7 mL, 6 mL can be recovered Mini blot: 3.5 mL per blot, 3 mL can be recovered	
Protocol steps	9	9
Washes per step	10	10
Rocks per minute	5 to 40, independent for each step	5 to 40 independent for each step

Power Requirement: 12 VDC, 5
Amp

Relative Humidity: 5 – 90% non
condensing

Operating Temperature: 4 - 40°C

Altitude: <2000m

Storage Temperature: -40 to 50°C

WARRANTY

Next Advance warrants its Products against defects in materials and workmanship for time periods which vary according to the Product. Within these time periods, Next Advance will replace or repair, without charge to the original purchaser, any part which is defective.

BlotBot warranty = Two years

The warranty is void if the Product is defective due to product accident, product modification, exposure to radiation other than for sterilization, connection to an improper electrical supply, lack of proper maintenance, contamination, improper installation or misuse. If the product is used in a manner not specified by the manufacturer, the protection provided by the equipment may be impaired. Also, The warranty shall also not apply to defects arising from fire, flood, lightning or other conditions unrelated to correct operation of the Product.

Next Advance's liability is limited, at the company's election, to (1) refund of the original purchaser's purchase price for the Product (2) repair of the Product, or (3)

Operator's Manual for the Freedom Rocker™ BlotBot®

replacement of the Product or defective parts. Evidence of purchase by the original purchaser is required. Next Advance may also request documentation of proper maintenance, if applicable.

Next Advance makes no other warranty, expressed or implied, with respect to its Products. **NEXT ADVANCE MAKES NO WARRANTY RESPECTING THE MERCHANTABILITY OF THE PRODUCTS OR THEIR SUITABILITY OR FITNESS FOR ANY PARTICULAR PURPOSE OR USE.** Next Advance shall not be liable for indirect, special, incidental or consequential damages of any nature. Any recovery for any claim shall be limited to the original purchase price for the product.

OPERATOR'S RESPONSIBILITY

Provide proof of purchase and provide normal care and maintenance.

WARNINGS AND CAUTIONS

Read this Operator's Manual before operating.

Do not open the window when the BlotBot is in use.

Use recommended accessories only. Substitutions may result in unsatisfactory performance.

Do not remove any panels or screws. No user serviceable parts are behind the panels.

For indoor use only.

Pollution Degree 2 per EN 61010-1.

Overvoltage Category II per EN 61010-1. Enclosure Protection: Not

Protected Against the Ingress of External Moisture.

Do not immerse in liquid.

DISCLAIMER

Next Advance, Inc. makes no representations or warranties, expressed, statutory or implied, regarding the fitness or merchantability of this product for any particular purpose. In no event shall Next Advance be liable for incidental or consequential damages. Next Advance, Inc. is not liable for any damages, including but not limited to, lost profits, lost savings, or other incidental or consequential damages arising from ownership or use of this product, or for any delay in the performance of its obligations under the warranty due to causes beyond its control.

Next Advance, Inc. also reserves the right to make any improvements or modifications to the product described in this manual at any time, without notice of these changes. Next

Advance, Inc. products are not designed, intended, or authorized for use in applications or as system components intended to support or sustain human life, as a clinical medical device for humans, or for any application in which the failure of the product could create a situation where personal injury or death may occur.

All brand and product names used in this manual are the trademarks of their respective owners.

CONTACT INFO

Next Advance, Inc.
Troy, NY, USA
Telephone 518-674-3510
www.nextadvance.com
Email: info@nextadvance.com

DOMINIQUE DUTSCHER SAS

