

MiniT-H2C/MiniT-H3

Incubator

Operation Manual

Version 1.0

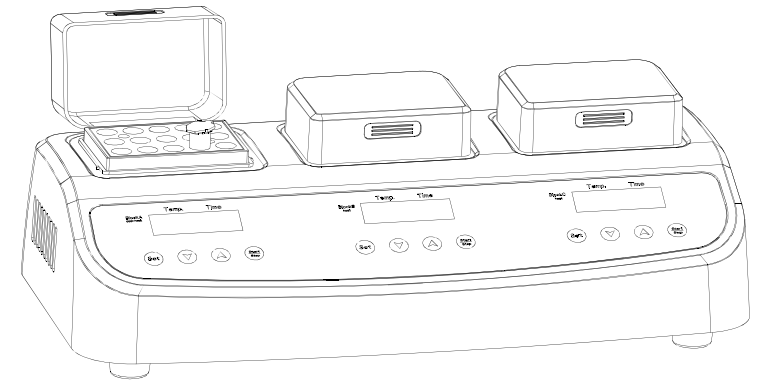

HANGZHOU ALLSHENG INSTRUMENTS CO., LTD.
ADD: 3#.Xiyuan Road 7th, Economic Park of Science
and Technology of the Westlake, Hangzhou city, Zhejia
Province,China
TEL: 86-571-88948289,88802738
FAX: 86-571-87205673
Website: www.allsheng.com www.allsheng.com.cn
Email: info@allsheng.com

ALLSHENG

ALLSHENG

HANGZHOU ALLSHENG INSTRUMENTS CO., LTD

Foreword

Thank you for purchasing our Products: MiniT-H2C/MiniT-H3 Incubator. This Manual for users contains function and operation of the Instrument. In order to use the instrument properly, please read this manual carefully before using the Instrument.

Opening Check

Please check the Instrument and Appendix with the packing list when you first open the instrument packing case. If you find there is something wrong with the Instrument and the Appendix, do contact the vendor or the producer.

Packing List

| No. | Item | Type | QTY |
|-----|-----------------------|------------|-----|
| 1 | Incubator | | 1 |
| 2 | Adapter | DC12V 120W | 1 |
| 3 | Wrench | | 1 |
| 4 | Operation manual | | 1 |
| 5 | Quality Certification | | 1 |

Annex 1 Wiring Diagram for Incubator MiniT-H2C

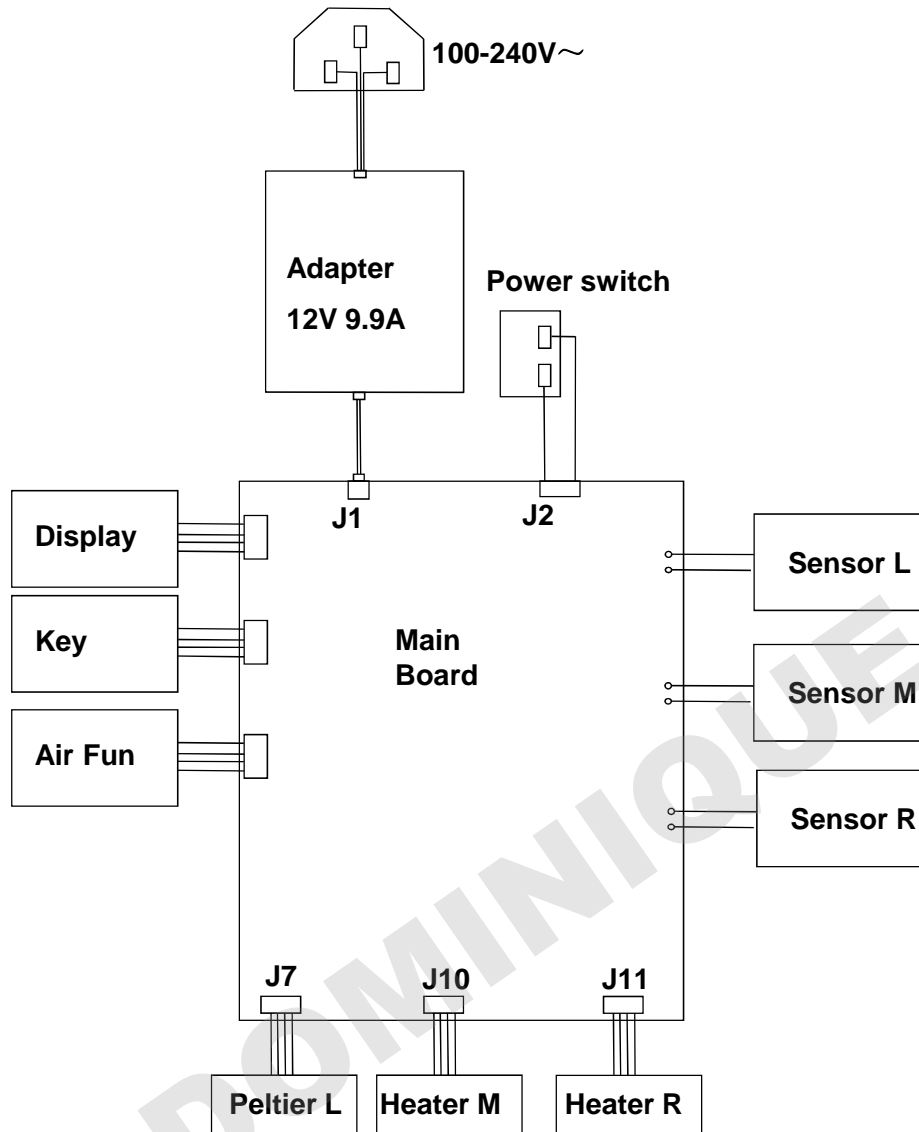

Contents

| | |
|--|----|
| 1. Introduction..... | 1 |
| 1.1 Delivery package..... | 1 |
| 1.2 Structure | 2 |
| 1.3 Installation instructions..... | 3 |
| 2. Technic data..... | 4 |
| 3. Safty warning..... | 5 |
| 4. Operation guide | 6 |
| 4.1 Operation and key..... | 6 |
| 4.2 Mode setting..... | 6 |
| 4.3 Temperature and time setting..... | 6 |
| 4.4 Run and stop | 7 |
| 4.5 Temperature calibration..... | 8 |
| 5.Maintenance and cleaning..... | 10 |
| 6.Troubleshooting | 10 |
| Annex 1 Wiring Diagram for Incubator | 11 |
| Packing list..... | 12 |

1 Introduction

This incubator is controlled by microcomputer. Widely apply in the field of sample preservation and reaction, DNA amplification and electrophoresis, degeneration, serum solidification, etc.

Before starting up this incubator for the first time, please read the rest of this operations manual.

1.1 Packing List

| | |
|-----------------------|---|
| Incubator | 1 |
| Adaptor | 1 |
| Wrench | 1 |
| Operation Manual | 1 |
| Quality Certification | 1 |

5 Maintenance and cleaning



The well in the block should be cleaned by the cloth stained with alcohol to assure good heat translation between the block and the test tube and no pollution. If there are smutches on the Instrument, clean them with cloth.



Power off when cleaning the Instrument.
When cleaning the well, don't drop the cleaning liquid in the well. Corrosive cleaning liquid is strongly prohibited.

6 Troubleshooting

| Error | Cause | Solution |
|------------------------------------|--|--|
| No display | No main power connection. Power failure. Main board is broken. | Plug in mains cable on both sides. Back to factory or contact service |
| "Err001" displayed and alarm | Temperature over 105°C | Power off or change main board |
| "E005" displayed and alarm | Open circuit of sensor | Back to factory or contact service |
| "E006" displayed and alarm | Short circuit of sensor | Back to factory or contact service |
| No heating or cooling of the block | Peltier or sensor broken | Back to factory or contact service. |
| Press invalid | Keyboard failure | Back to factory or contact service |

4.5.3 Press “▲” and “▼” key simultaneously on any block, instrument shows calibration interface, top left sign “1” means it is calibration at 5.0°C for Block A area. Other two block area show ambient temp. Block A area temperature control at 5.0°C. Time show “Adj”. “Adj” twinkle regularly after temp reach 5.0°C. Same time not input any value on Block B or Block C.

4.5.4 After 20 mins constant temperature, "Adj" stop twinkle and decimal point of temp begin. Read value on thermometer, such as the value is 4.9°C, then press “▲” or “▼” to amend display value to 4.9°C. Press "Start/Stop" to confirm.

4.5.5 After confirmation by press "Start/Stop", all of three block area will heating to 40.0°C automatically and top left show "2".

4.5.6 After temperature arrive at 40.0 °C "Adj" twinkle regularly.

4.5.7 After 20 mins constant temperature, "Adj" stop twinkle and decimal point of temp begin. Read value on thermometer of 3 block, such as the value is 39.8, 39.5, 39.0 then press “▲” or “▼” to amend display value same as above. Press "Start/Stop" to confirm.

4.5.8 After confirmation by press "Start/Stop", all of three block area will heating to 99.9°C automatically and top left show "3".

4.5.9 After temperature arrive at 99.9 °C "Adj" twinkle regularly.

4.5.10 After 20 mins constant temperature, "Adj" stop twinkle and decimal point of temp begin. Read value on thermometer of 3 block, such as the value is 99.2, 99.0, 99.1 then press “▲” or “▼” to amend display value same as above. Press "Start/Stop" to confirm.

4.5.11 Screen back to start display interface and re-control temperature again to aim temp.

Note: 1. Input each data show by thermometer to every block. Only both 3 blocks' calibration ending on same temperature. Next calibration on another temperature can be done.

2. During Temperature calibration, press “▲” and “▼” key simultaneously to cancel the calibration. The system keeps the former calibration. So don't press “▲” and “▼” key simultaneously unless need calibrate the temperature!

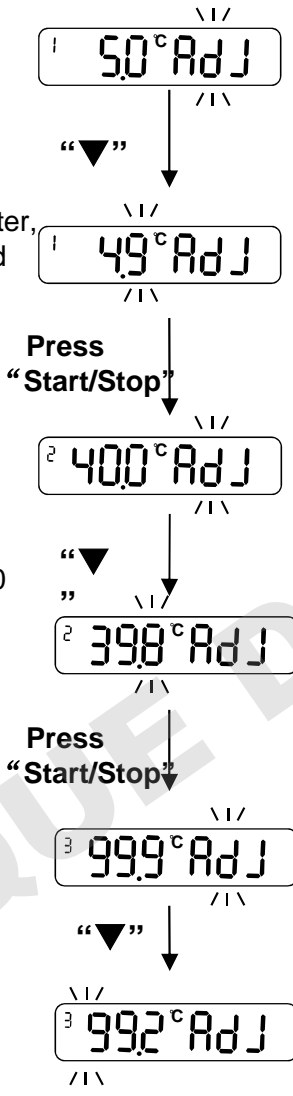

1.2 Structure

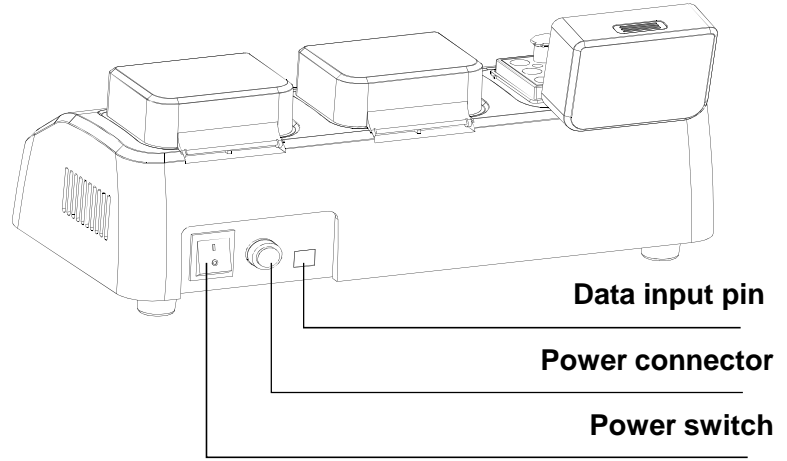
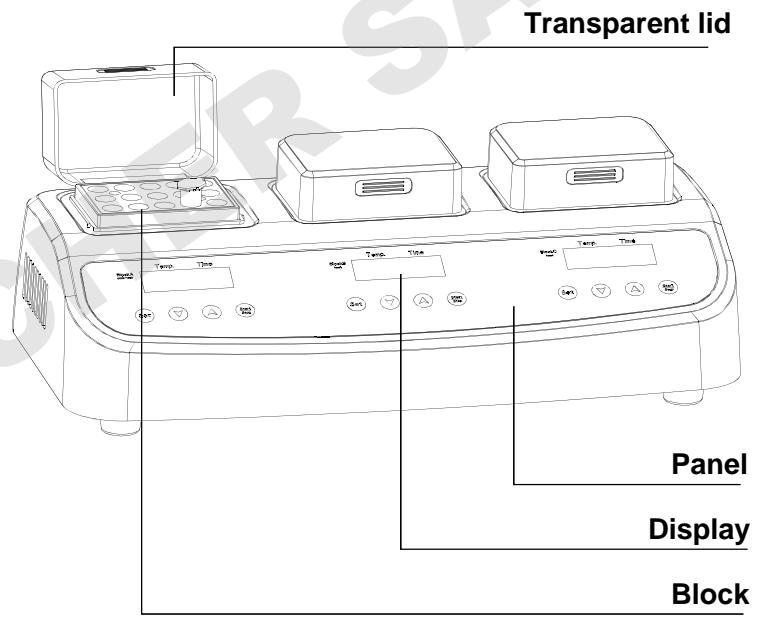

1.3 Installing the device

1.3.1 Place the incubator onto a level, horizontal surface.

1.3.2 Insert the column connector of the adapter to power connector of the device, and insert another connector of the adapter to mains power supply(100~240V).

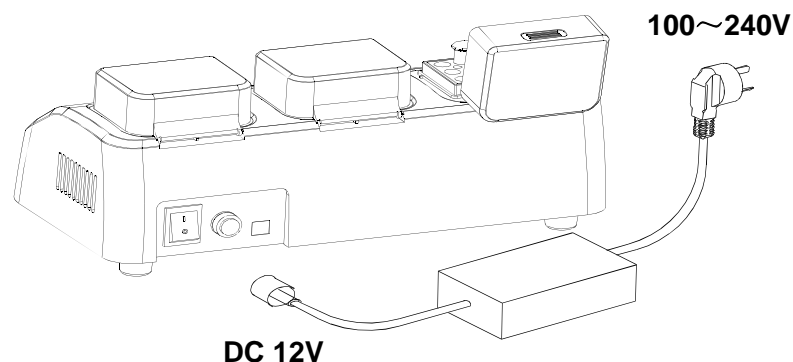

1.3.3 Power on the main switch. Current temperature will be displayed.

1.3.4 After temperature reach the aim one. Put the test tube into the block, then put on the lid.

4.5 Temperature calibration

Temperature of the instrument has been calibrated before out of factory. But if there is deviation between the actual temperature and the displayed temperature due to some reasons, you can do as follows to calibration.

Notes: The Instrument uses three temperatures adjustment to ensure its veracity. This means it is linearly calibrated on 5°C, 40°C and 99.9°C three points. The temperature veracity will be within $\pm 0.5^\circ\text{C}$ after the three temperature adjustment.

(MiniT-H3 is calibrated on 40°C and 99.9°C two point linearly calibration)
Temperature of circumstances and both 3 blocks should be lower than 30°C.

Notice: Calibration have been done before factory delivery, only do this when necessary.

Adjustment methods as follows:

4.5.1 Power on the instrument, and emerge the waiting interface

4.5.2 Inject mineral oil into one of the cone-shaped wells of each block, and then put thermometer into the wells (Make sure the precision of the thermometer should be within 0.1°C and the temperature ball should be absolutely immersed into the cone-shaped well). Seeing from Fig a.

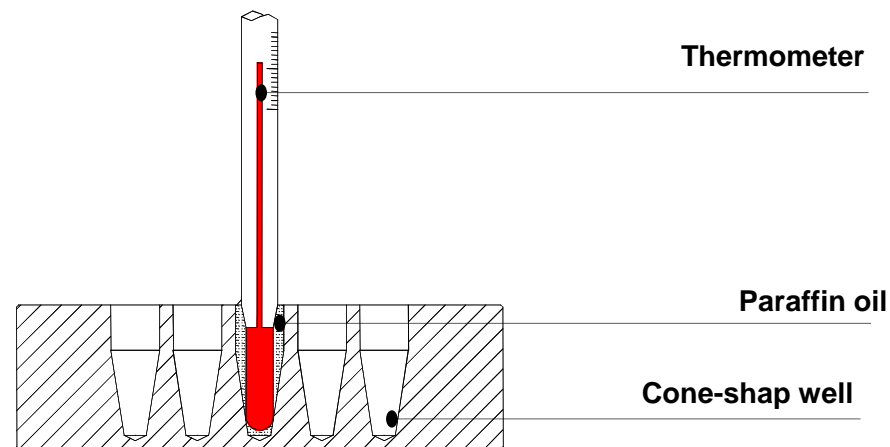
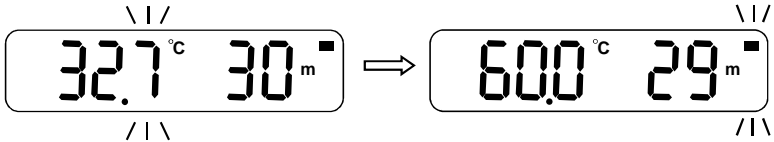

Fig a.

4.4 Run and Stop

4.4.1 After temperature and time settle down, instruments heating automatically. Press "Start/Stop" after reach the setting value. Same time, constant temperature begin timing and "■" "twinkle in the up right.

Note: Decimal point twinkle regularly stand for instrument is still in heating process. Press "Start/Stop" instruments will count down after a constant temperature.



4.4.2 It will stop after long press "Start/Stop" 2s during instrument running. Press this key again, then re-start.

4.4.3 End of the timing, buzzer alarm 5 times. Temperature is setting value (Factory default mode "0n ") Time is shown as "End "











4.4.4 End of instrument running, it shows as ending interface. Press any key to back program interface.

2 Technic data

| Model | MiniT-H2C | | | MiniT-H3 | | |
|--------------------------|--|---------|---------|--------------------------------|---------|---------|
| Parameter | | | | | | |
| Block | Block A | Block B | Block C | Block A | Block B | Block C |
| Temperature range | 0°C~99.9°C | | | Room temperature +5°C ~ 99.9°C | | |
| Ambient temperature | 5°C ~ 30°C | | | | | |
| Heating and cooling time | ≤25min (from 20°C to 0°C) | | | ≤20min (from 25°C to 99.9°C) | | |
| Block quantities | 3 | | | 3 | | |
| Timing range | 1 ~999 hrs 1 ~999 min 1 ~999 sec | | | | | |
| Power supply | DC12V | | | | | |
| Power | 120W | | | | | |
| Temperature accuracy | ≤ ±0.5 °C | | | | | |
| Temperature Uniformity | ≤ ±0.5 °C | | | | | |
| Display accuracy | ±0.1°C | | | | | |
| Dimensions (W×D×H) | 360mm×180mm×150mm | | | | | |
| Weight (kg) | 3.0 | | | | | |

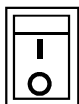
NOTE: This Dry Bath can reach to 0°C when the ambient temperature less than 25°C and can reach to 4°C when the ambient temperature less than 30°C.

3 Safety warning

-  This product is for indoor use.
-  Read the Manual carefully before operation, Device must be used by skilled personnel with the appropriate training.
-  The operator should not open or repair the instrument by yourself, this will result in losing the qualification of repair guarantee or occur accident. If there is something wrong with the instrument, the factory will repair it.
-  The Instrument should be put in the place of low temperature, little dust, no water and no sun or strong lamp. What's more, the place should be good aeration, no corrosively gas or strong disturbing magnetic field, far away from central heating, camp stove and other hot resource. Don't put the Instrument in wet and dusty place.
-   Mains switch is on the rear of the device, push "I" to power on the device, and push "O" to power off the device.
-   Power connector is on the rear of the device, DC12V input, inside is "+", Outside is "-".
-  Power off when you finish your work. Pull off the connector plug when there's long time no use of the Instrument and cover it with a cloth or plastic paper to prevent from dust.

4. Operation guide

- 4.1 Operation and key
 - Start/Stop----start or stop the program
 - Set-----set the program
 - ▲ ▼ -----set temperature and time
- note: Panel control field correspondence with each block

4.2 Mode setting

Press "Set" and "▼" at same time in any block field. Power on instrument and there is "On" show in screen. Means temperature is setting temperature after instrument run. (This is default setting out of factory). Press "▲" or "▼" to change mode, if display "OFF" means temperature down to ambient temperature automatic after run. It will exist setting mode 3S later.

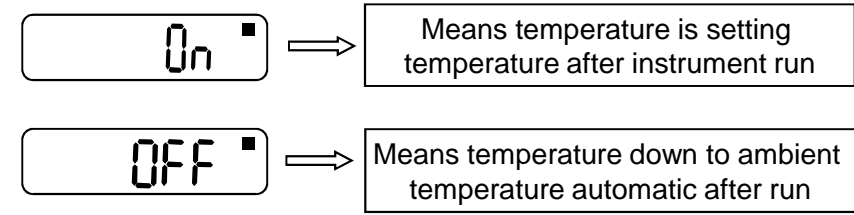

4.3 Temperature and time setting

Power on instrument, Display glitter 3 times and with voice "di", instruments go into initialization status. Press "Set" Key, temperature is glitter, then press "▲" or "▼" to change the temperature. Keep press "set" time is glitter, then press "▲" or "▼" change time. Continue press "Set" unit of time begin to glitter, press "▲" or "▼" to change time unit ("h" stands for hour, "m" stands for minute, "S" stands for second). Press "Start/Stop" to confirm and exist setting mode or just wait 3 seconds, it will exist automatic.

Note: Users can long press "▲" or "▼" to change the setting value.

