



## CLS-1445 Series Spinner Flask Instruction Manual



Chemglass Life Sciences  
3800 North Mill Road  
Vineland, NJ 08360 USA  
Phone: 800-843-1794

Email: [customer-service@cglifesciences.com](mailto:customer-service@cglifesciences.com)

Web address: [www.cglifesciences.com](http://www.cglifesciences.com)

Rev. A 02/05/13

# CLS-1445 Series Spinner Flask Instruction Manual

## Description:

The Chemglass Life Sciences spinner systems are designed for long life, high efficiency and low maintenance. Spinners are the ideal environment for culturing a wide variety of cell cultures such as insect cells, hybridomas and many other suspension adapted cells.

## Features:

All sizes feature a flat bottomed vessel  
Heavy wall center port and side arms  
FDA approved materials

## Material Specifications:

Spinner flasks are constructed of high quality components with the following specifications:

Vessels:	Borosilicate type 1 glass
Shafts:	Borosilicate glass 7mm
Magnets:	PTFE encapsulated
Cap:	Polypropylene
Compression fitting:	Polypropylene
Liner:	Silicone
O-ring:	Silicone

Material certifications:	21 CFR 177.1550
	21 CFR 177.2600
	TSE\BSE Declarations
	ASTM E-438, USP Type 1, Class A glass

Material certifications are available upon request.

## Manual Symbols:



The warning symbol indicates attention to an operation that could cause injury, equipment or process damage.

## Operating and Assembly Instructions:

The cap and magnet assemblies are shipped partially assembled.

### Glass Rod Installation (refer to Figure 1):

Remove the magnet from the magnet holder by pushing the magnet through the holder until free. Insert the glass shaft into the hole in the bottom of the magnet holder and re-install the magnet.

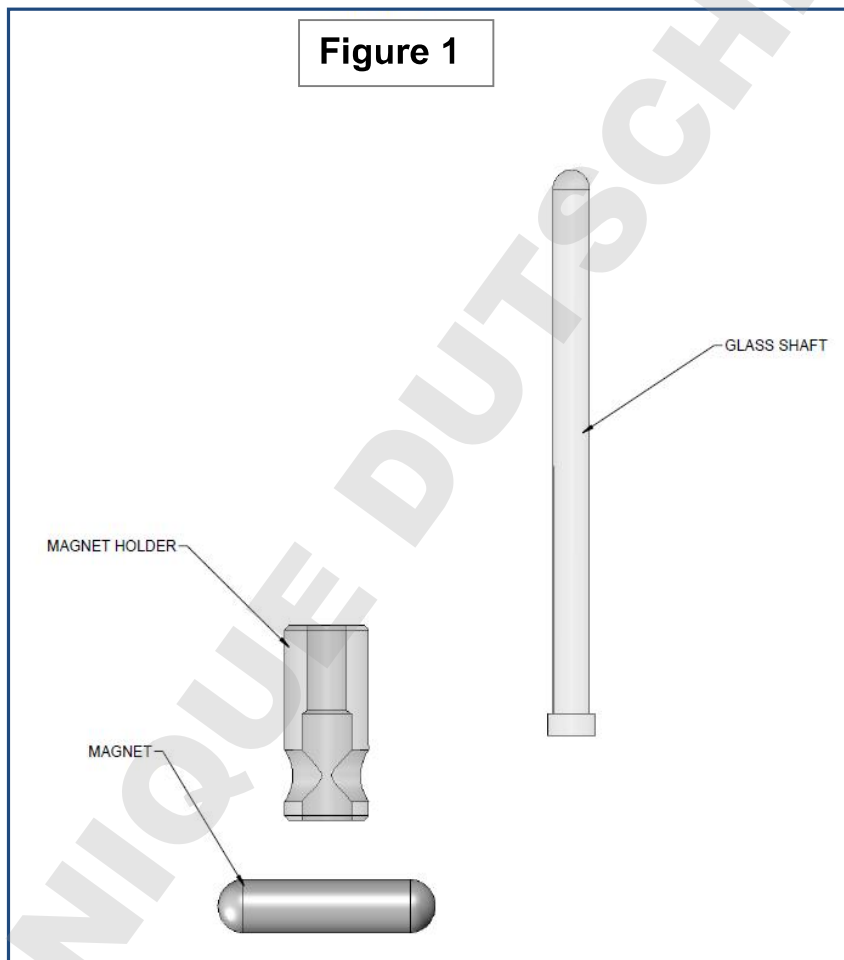

**WARNING:** Be careful handling the glass shaft as accidental breakage can cause injury

## Magnet Assembly Installation (refer to Figures 2 & 3):

Loosen the cap nut from the cap but do not completely remove. For easier installation, moisten the glass shaft with water and gently slide it through the cap assembly from the bottom through compression fitting body and then hand tighten the cap nut loosely to hold the magnet assembly in place.

Place the entire assembly into the flask and adjust the height of the magnet by sliding the glass shaft either up or down until the desired height is achieved (see figure 3). Next tighten the cap nut to lock the magnet height.

Figure 2

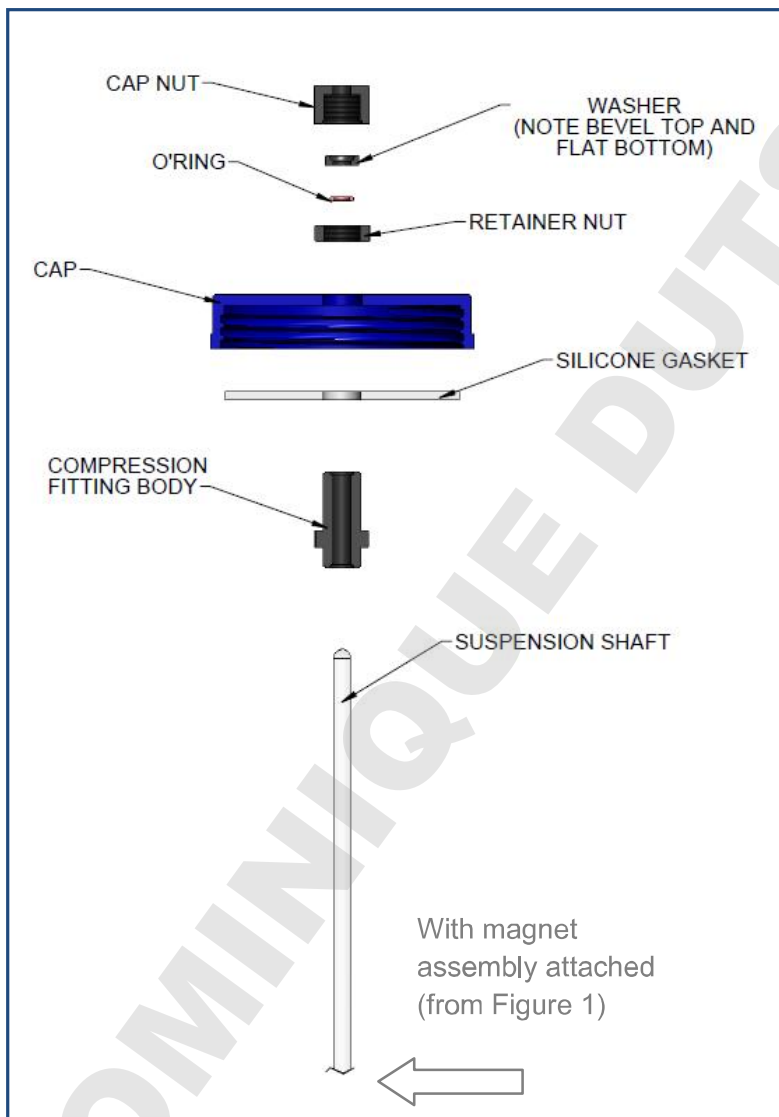
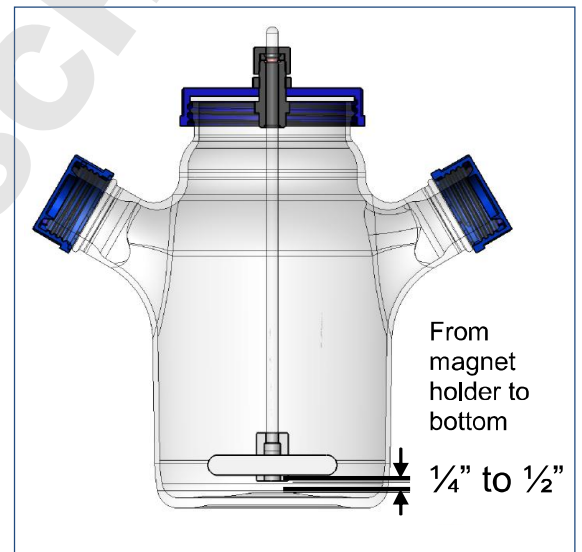
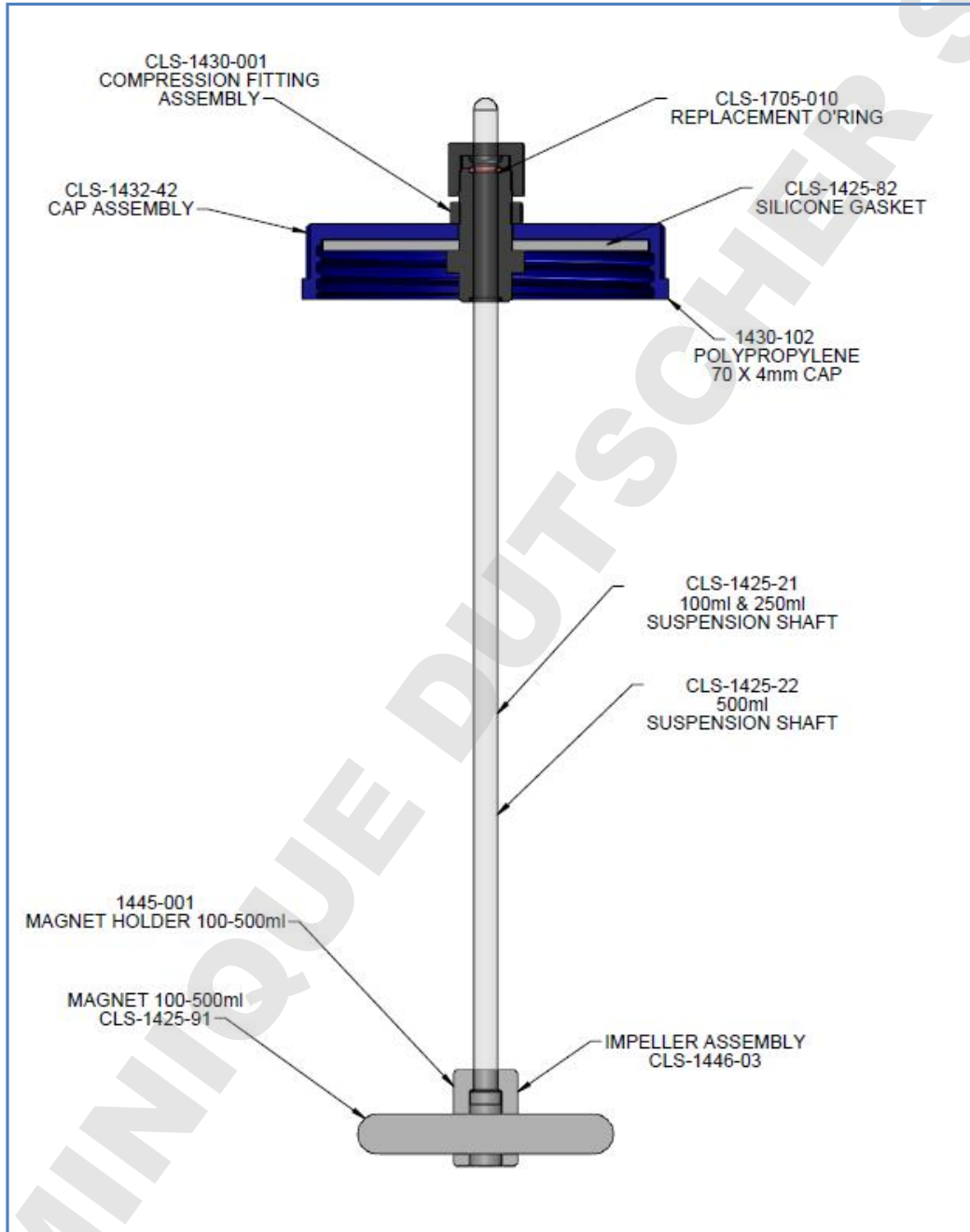

Figure 3



**WARNING:** Be careful handling the glass shaft as accidental breakage can cause injury

## 100mL, 250mL & 500mL Spinners



## 1L & 3L Spinners

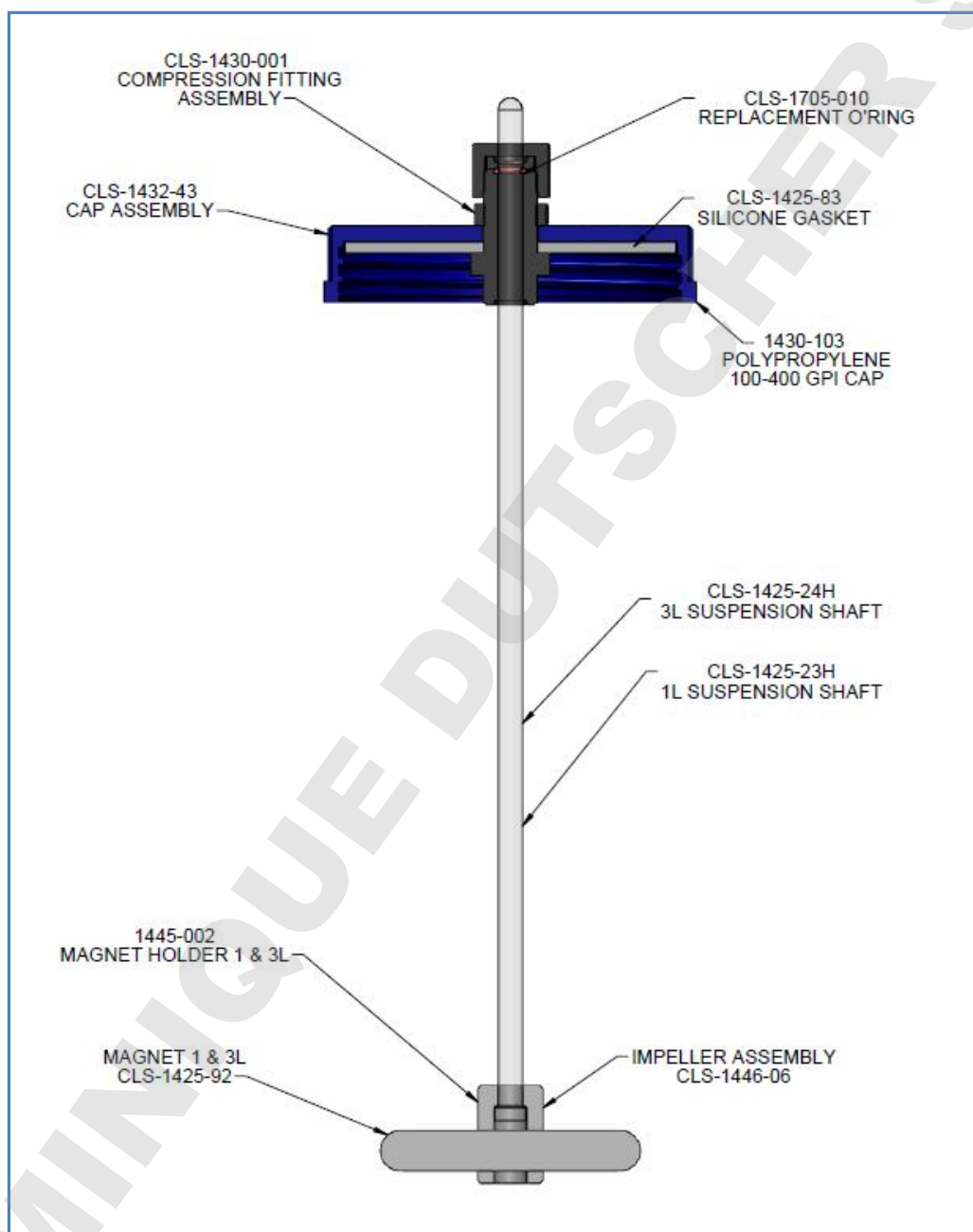

## **Cleaning:**

Use a commercial cleanser approved for glass. Chemglass Life Sciences recommends item number [CLS-4752](#), 7X™ and 7X-O-Matic® cleaning solutions.

Rinse all glassware as soon as possible after use.

To decontaminate ware, autoclave contaminated items in water containing cleanser.

Disassemble spinner assemblies, compression fittings and paddle assemblies for cleaning and to avoid the trapping of disinfectants and cleansers. Failure to do so may result in the release of these compounds during use with possible detrimental effects to cultures or assays.

Thoroughly rinse items in tap water then distilled or deionized water - even the smallest products. Rigorously follow your rinsing protocol.

**Do not use glassware that is scratched, chipped or cracked for centrifugation, pressure, vacuum, heating or freezing. Breakage may result.**

## **Sterilizing:**

To prevent warping of the top cap and magnet holder, it is recommended that the flask be autoclaved in the standing position only. In large vessels, place a few ml of distilled water in the flask to generate additional steam in the vessel. Place approximately 20 ml of water (or PBS buffer) for each 10 liter of flask volume and autoclave @ 121C for 15 to 30 minutes.



**Make sure that the vessel is vented so that pressure or vacuum will not build up and cause vessel to explode or implode.**

## **Chemglass Life Sciences Warranty and Limitation of Liability**

### **Guarantee:**

Chemglass Life Sciences, herein known as CGLS, warrants the equipment to be free from all defects and guarantees acceptable performance assuming the equipment has been installed in accordance with the instructions provided by CGLS, and has been used for the specific design purpose, and has been maintained according to the maintenance instructions accompanying the equipment or other CGLS published documents. The warranty period is for one year from the date of sale. If the unit is determined to have a defect in materials or workmanship, then it will be repaired or replaced at no charge.

**NOTE: THE MAGNET HOLDER (P/N'S: 1445-001 and 1445-002) WILL WEAR OVER TIME AND SHOULD BE INSPECTED AND REPLACED PERIODICALLY**

## Return Authorization:

CGLS must authorize any return of material. Please contact a customer service representative at the correspondence listed below to obtain a Return Merchandise Authorization (RMA) number. The purchaser is responsible for all packing and shipping to CGLS. If the equipment or material came in contact or was proximate to any biological organism, toxic or corrosive material, or any agent reasonably deemed to be potentially harmful, it must be cleaned and decontaminated prior to receipt by CGLS. The purchaser is obligated to disclose fully in writing, the cleaning and decontamination method. We reserve the right not to accept any unauthorized or potentially harmful shipment.

Correspondence:

Chemglass Life Sciences

3800 North Mill Rd.

Vineland, NJ 08360

USA

Phone: 800-843-1794

Email: [customer-service@cqlifesciences.com](mailto:customer-service@cqlifesciences.com)

Web: [www.cqlifesciences.com](http://www.cqlifesciences.com)

