



FastGene[®]

PAGE PROTEIN SYSTEM



PG01 Manual

 **NIPPON Genetics EUROPE**
Innovation for you!

NIPPON Genetics EUROPE GmbH Mariawellerstraße 28-30, 52349 Düren, Germany.
Tel: +49 2421 5549 60, Fax: +49 2421 55496 11, E-Mail: info@nippongenetics.de, www.nippongenetics.eu





DOMINIQUE DITSCHER SAS



CONTENT

1. INTRODUCTION.....	P. 5
2. SYSTEM COMPONENTS.....	P. 7
2.1 Ordering Information.....	P. 7
2.2 FastGene® PAGE Protein Sytem (PG01).....	P. 8
2.2.1 PAGE System Set Components.....	P. 8
2.2.2 Gel Hand-Casting Set Components.....	P. 11
3. SYSTEM OPERATION.....	P. 13
3.1 Gel Hand-Casting.....	P. 13
3.1.1 Assembly of Gel Hand-Casting Set.....	P. 13
3.1.2 Polyacrylamide Gel casting.....	P. 16
3.2 PAGE System Operation.....	P. 19
3.2.1 U Sealing Strips for Pre-Cast and Hand-cast gels.....	P. 19
3.2.2 Gel Cassette Assembly.....	P. 20
3.2.3 PAGE System Chamber Assembly.....	P. 22
3.2.4 Sample Preparation.....	P. 23
3.2.5 Sample Loading.....	P. 24
3.2.6 Performing Electrophoresis.....	P. 25
4. TROUBLE SHOOTING.....	P. 27
5. WARRANTY.....	P. 31
6. CONTACT INFORMATION.....	P. 31



DOMINIQUE DUTSCHER SAS



1. INTRODUCTION

Thank you for purchasing the FastGene® PAGE Protein System. The system is compatible with hand-cast gels and pre-cast gels (e.g. FastGene® gels, Bio-Rad TGX™ gels and ThermoFisher™ mini gels) for electrophoretic protein separation. It can run a maximum of 4 gels simultaneously.

PAGE stands for Polyacrylamide Gel Electrophoresis and describes an analytical method in biochemistry for the separation of differently sized protein mixtures in an electric field. During PAGE, proteins migrate through a gel matrix in response to an applied electric field. Smaller proteins travel faster through the gel than larger proteins, leading to a size dependent separation.

The most common form of PAGE is SDS-PAGE. The detergent sodium dodecyl sulfate (SDS) is added for PAGE sample preparation and is also part of the buffer composition. The treatment with the harsh detergent leads to full protein denaturation and unfolding. SDS binds to hydrophobic parts of the unfolded protein and masks the intrinsic charge of the protein with its own negative charge. As a consequence, SDS-protein complexes migration is predominantly dependent on the size of the protein, allowing an estimation of its molecular weight.

After the PAGE protein separation is completed, protein visualization and detection is carried out. Protein visualization is achieved by the use of protein specific stains. After staining, images can be taken of the gel for analytical purposes.



DOMINIQUE DUTSCHER SAS



2. SYSTEM COMPONENTS

2.1 Ordering Information

Following sets / components are available, additionally to the FastGene® PAGE Protein System (PG01):

Cat. No.	Product	Content
PG01	FastGene® PAGE Protein System	Complete protein PAGE set (for content list see table on next page)
PG02	FastGene® Comb Set 075	Gel hand-casting set (for 0.75 mm gel thickness) (for content list see table on next page)
PG03	FastGene® Comb Set 150	Gel hand-casting set (for 1.5 mm gel thickness) (for content list see table on next page)
PG04	FastGene® Glass plates short	Short flat glass plates for hand-cast gels (10 glass plates)
PG05	FastGene® Gel/Blot chamber tank	Large gel electrophoresis buffer tank (1 chamber tank)
PG06	FastGene® Gel casting clip	Frame for holding hand-cast gels (4 pieces)
PG07	FastGene® Sealing gaskets	Sealing gaskets for gel casting (5 pieces)



2.2 FastGene® PAGE Protein System (PG01)

Please check the system and the packing list when you first open the packing case of the FastGene® PAGE Protein System. If you find there is something wrong with the system or the packaging content, please contact NIPPON Genetics EUROPE or your local distributor.

The FastGene® PAGE Protein System (PG01) contains PAGE System components and Gel casting set components for hand cast gels:

FastGene® PAGE Protein System (PG01)	Qty
PAGE System set	1 set
Gel hand-casting set (1 mm gel thickness)	1 set

2.2.1 PAGE System Set Components

The PAGE System set components of PG01 allow to execute electrophoretic separation of proteins with the use of polyacrylamide gels.

FastGene® PAGE Protein System (PG01) - PAGE System		Qty
PAGE System	Inner electrophoresis chamber with electrodes (with side clip for gel holder 2x)	1
	Inner electrophoresis chamber without electrodes (with side clip for gel holder 2x)	1
	U sealing strip long for 10 x 10 cm gels (e.g. ThermoFisher mini gels)	4
	U sealing strip short for Bio-Rad TGX™ gels (10 x 8 cm)	4
	U sealing strip FastGene (10 x 8 cm)	4
	Plastic dummy cassette short (10 x 8 cm)	1
	Plastic dummy cassette long	1
	FastGene® Gel/Blot chamber lid with electrodes (and power cable)	1
	FastGene® Gel/Blot chamber tank (PG05)	1
	Gel shovel	5



1. FastGene® Gel/Blot chamber lid with electrodes (and power cable)

3. Inner electrophoresis chamber with electrodes (with side clip for gel holder 2x)

2. FastGene® Gel/Blot chamber tank

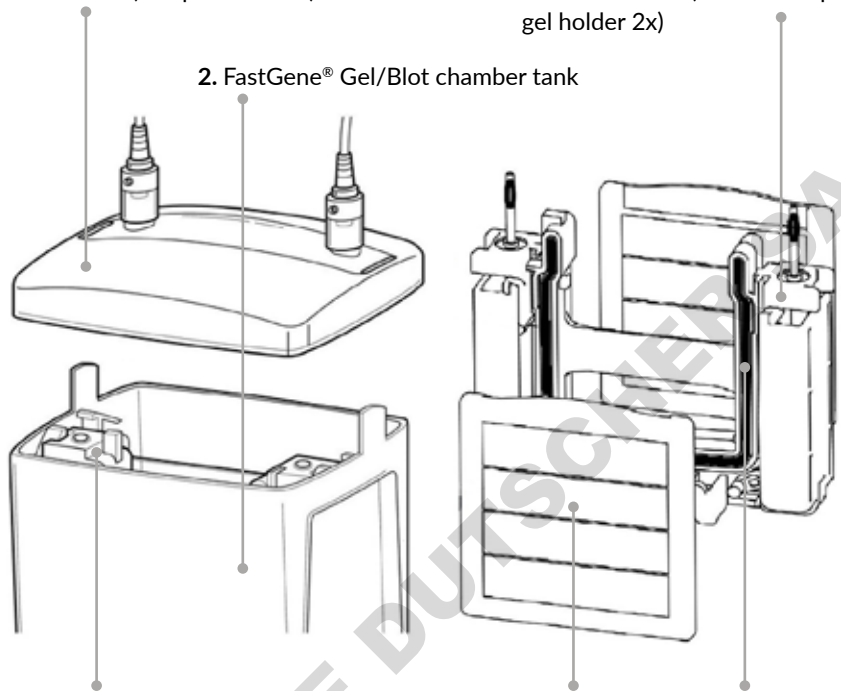

4. Inner electrophoresis chamber without electrodes (with side clip for gel holder 2x)

5. Hand-cast gel /
Pre-cast gel /
Plastic dummy cassette

6. U sealing strip

Fig. 1: PAGE system components



Description of PAGE system components (depicted in Fig. 1):

1. FastGene® Gel/Blot chamber lid with electrodes (and power cable):

The lid is positioned on top of the inner electrophoresis chambers and the FastGene® Gel/Blot chamber tank. The power cables (cathode and anode) are connected to the power supply.

2. FastGene® Gel/Blot chamber tank:

The chamber tank holds both inner electrophoresis chambers with a maximum of four gels/plastic dummy cassettes. The chamber is filled with running buffer during the electrophoresis run.

3. Inner electrophoresis chamber with electrodes:

Holds two gels/plastic dummy cassettes via the two gel side clip holders. The inner chamber is filled with running buffer during the electrophoresis run. The lid is connected to the inner chamber electrodes.

4. Inner electrophoresis chamber without electrodes:

Holds two gels/plastic dummy cassettes via the two gel side clip holders. The inner chamber is filled with running buffer during the electrophoresis run. The lid is placed on top of the inner chamber electrodes.

5. Hand-cast gel / Pre-cast gel / Plastic dummy cassette:

The system is compatible with hand-cast gels and pre-cast gels (e.g. FastGene® gels, Bio-Rad TGX™ gels and ThermoFisher™ mini gels) for electrophoretic protein separation. In case 1 or 3 gels are used with the system, a gel is replaced with a short or long plastic dummy cassette.

6. U sealing strip:

The U sealing strips are placed between the inner electrophoresis chambers and the gels/plastic dummy cassettes on both sides. They seal the inner electrophoresis chamber (cathode) from the (outer) gel/blot chamber tank (anode). Depending on the gel size and gel type, different U sealing strips are used (See page 19 for the use of compatible U sealing strips).



2.2.2 Gel Hand-Casting Set Components

The FastGene® PAGE Protein System (PG01) is equipped with a gel hand-casting set for the preparation of hand-cast (polyacrylamide) gels with 1 mm gel thickness. The FastGene® Comb Set 075 (PG02) and FastGene® Comb Set 150 (PG03) are available for the preparation of 0.75 mm gels and 1.5 mm gels, respectively.

FastGene® PAGE Protein System (PG01) - Gel hand-casting set				Qty
Gel hand-casting set (1 mm gel thickness)	Comb 1 mm 10 wells	PG02 (0.75 mm)	PG03 (1.5 mm)	5
	Comb 1 mm 15 wells			5
	Glass spacer long 1 mm			5
	Glass plates short (PG04)			10
	Gel casting base			4
	Gel casting clip (PG06)			4
	Sealing gaskets (PG07)			5
	Glass plate holder			1
	Tube holder			1

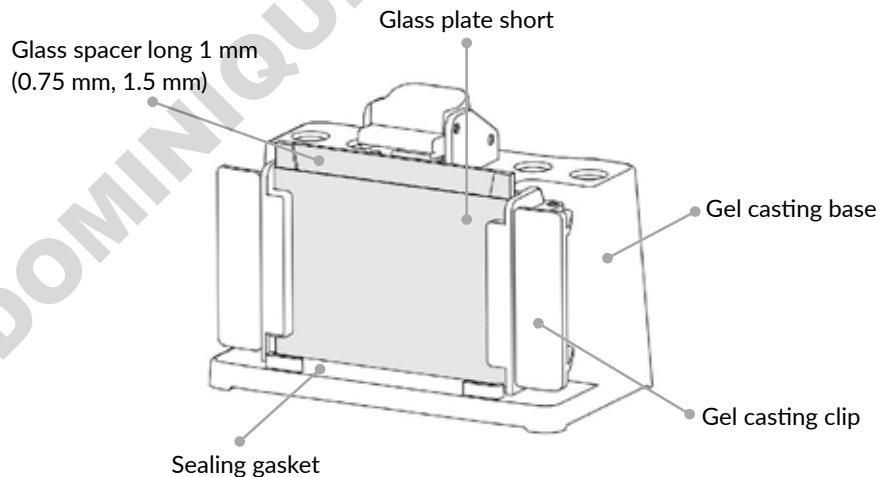

Fig. 2: Gel hand-casting set components



DOMINIQUE DUTSCHER SAS



3. SYSTEM OPERATION

Please read the instructions manual carefully and operate the system accordingly.

3.1 Gel Hand-Casting

If you are using ready-to-use pre-cast gels, skip this section and continue with section 3.2 PAGE System Operation.

3.1.1 Assembly of Gel Hand-Casting Set

- 1 Assemble the glass spacer (1 mm, 0.75 mm or 1.5 mm) together with a glass plate on top.

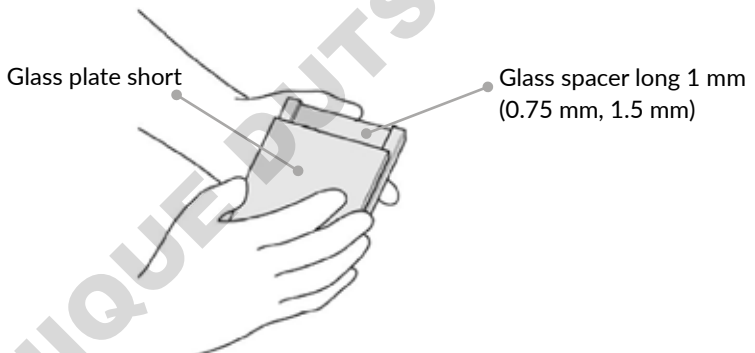

- 2 Place the gel casting clip on a horizontal lab desk and keep both hinges of the frame open. Position the short glass plate towards the front and slide the assembled glass spacer and glass plate into the gel casting clip from the top.

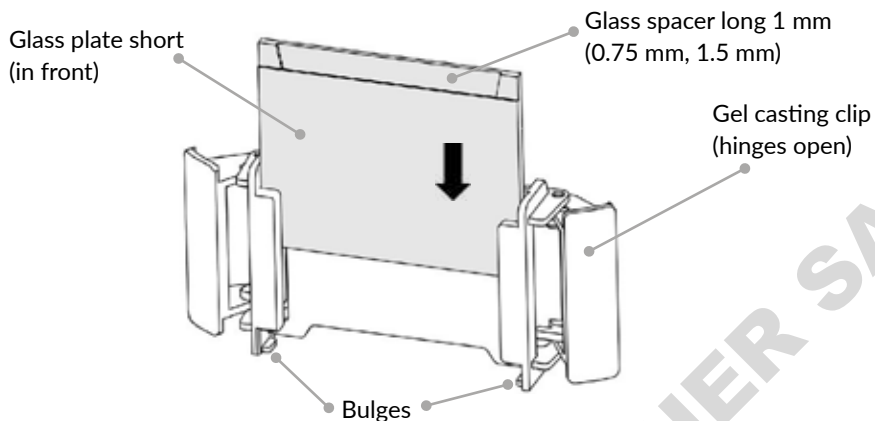

3

The two glass plates should be aligned and both rest on the two bulges at the bottom of the gel casting clip. Close the hinges on both sides of the gel casting clip.

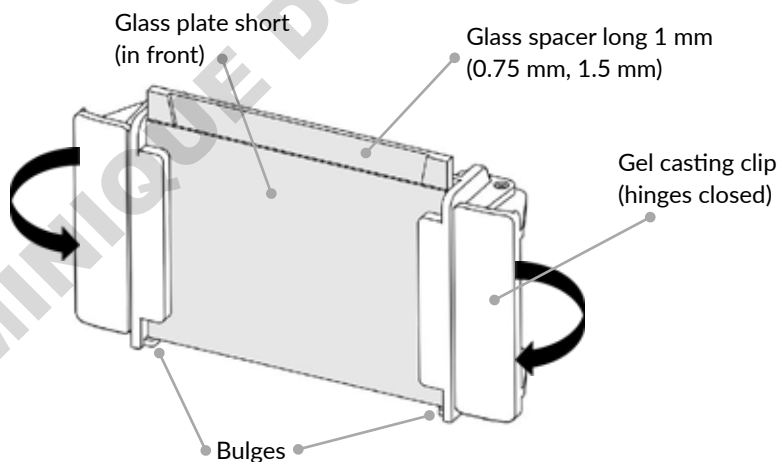

4

Carefully check that both glass plates are level with each other and are aligned at the bottom of the gel casting clip. Adjust if necessary. A wrong alignment can lead to leakage during gel casting.



- Put a sealing gasket in the rectangular cavity in the front of the gel casting base. Position the closed gel casting clip with glass plates on top of the sealing gasket, as shown below.

Gel casting clip with glass plates (hinges closed)

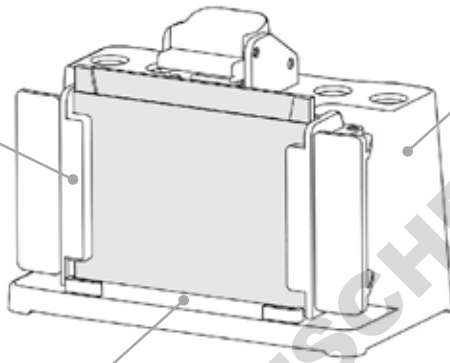

Gel casting base

Sealing gasket

- Fix the the glass plates and gel casting clip to the gel casting base by pulling the spring leverage to the front and securing the top of the glass spacer (1 mm, 0.75 mm, 1.5 mm)

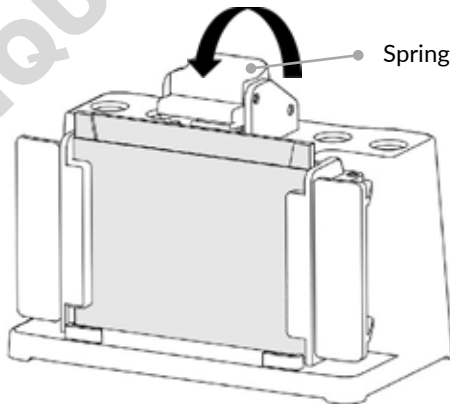

Spring leverage

- Continue with polyacrylamide gel casting. Repeat steps 1-6 when casting more than one gel.



3.1.2 Polyacrylamide Gel Casting

For ideal protein separation, hand-cast polyacrylamide gels are divided into two parts, a stacking gel and a resolving gel. The stacking gel has a lower pH (pH 6.8) and a lower polyacrylamide percentage (4%) than the resolving gel. It is cast around the comb on the upper part of the gel. The purpose of the stacking gel is to line up the loaded protein samples so they can enter the resolving gel simultaneously. The resolving gel has a higher pH (pH 8.8) and a higher gel percentage (~7.5 % - ~20 %) than the stacking gel. It separates proteins based on their molecular weight.

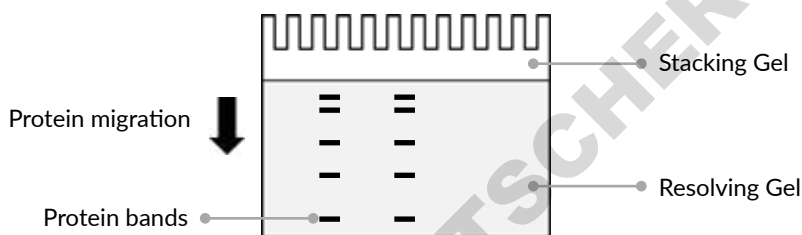

Fig. 3: Stacking gel and resolving gel

1

For preparing the stacking gel and resolving gel, mix the gel solutions listed in the following table **without TEMED and APS**. The component volumes are given for a total volume of 6 ml (4 %) stacking gel and 15 ml (12 %, X %) resolving gel. See the table on page 17 for required volume per gel.

Solution Components	Stacking Gel	Resolving Gel		Final concentration
	4 %	12 %	X % (for 15 ml only)	
30 % Acrylamide/Bis	0.8 ml	6 ml	(0.5*X) ml	variable
0.5 M Tris HCl, pH 6.8	1.5 ml	-----	-----	0,125 M
1.5 M Tris HCl, pH 8.8	-----	3.75 ml	3.75 ml	0,375 M
10 % SDS	60 µl	150 µl	150 µl	0.1 %
H ₂ O (deionized)	3,604 ml	5,01 ml	11,01 - (0.5*X) ml	-----
TEMED	6 µl	15 µl	15 µl	0,1 %
10 % APS	30 µl	75 µl	75 µl	0,05 %
Total Volume	6 ml	15 ml	15 ml	

*Add later,
right before gel casting
(step 5 and step 7)



- 2 The following table shows the gel volumes of 0.75 mm, 1 mm and 1.5 mm gel casting plates. If necessary, adjust the total volumes for used gel thickness and number of hand-cast gels accordingly.

Hand casting gel thickness	Gel volume (stacking gel + resolving gel)
0.75 mm	~ 6.06 ml
1 mm	~ 4.54 ml
1.5 mm	~ 9.09 ml

- 3 Degas the polyacrylamide gel solution without TEMED and APS and prepare the hand gel casting set in the meantime (see 3.1.1 Assembly of Gel Hand-Casting set).
- 4 Insert a comb between the two glass plates of the assembled gel casting set to mark the casting level of the resolving gel and stacking gel. A sufficient amount of stacking gel is needed for proper protein band sharpness. Mark ~1 cm below the teeth of the comb on the glass plate. The resolving gel will be poured up to this level and covered with stacking gel afterwards. Remove the comb again.

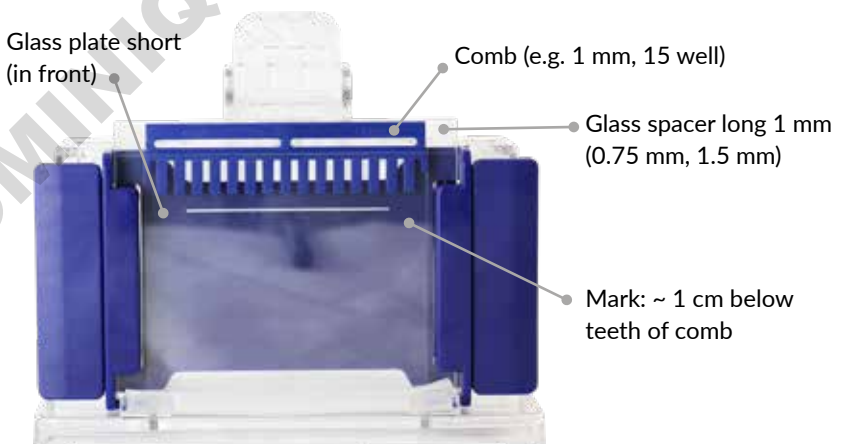



- 5 **Resolving gel:** Add TEMED and APS to the degassed polyacrylamide resolving gel solution. Gently swirl the vessel without drawing air bubbles into the solution. This will start the polymerization reaction. Subsequently pour the resolving gel solution between the glass plates using a glass pipette, until the mark on the glass plate (from step 4) is reached. Avoid air bubbles during pouring.
- 6 Immediately cover the resolving gel solution with 100% isopropyl alcohol (propan-2-ol) or water saturated n-butanol. Let the resolving gel solution polymerize for 45 - 60 min. Afterwards, pour off the solvent and rinse the top of the resolving gel with deionized H₂O.
- 7 **Stacking gel:** For pouring the stacking gel, first dry the top of the resolving gel by using filter paper.
- 8 Add TEMED and APS to the degassed polyacrylamide stacking gel solution. Gently swirl the vessel without drawing air bubbles into the solution. Pour the stacking gel solution between the glass plates on top of the resolving gel using a glass pipette, until the brim of the front glass plate is reached. Avoid air bubbles during pouring. Carefully and slowly insert the comb to avoid air trapping under the teeth of the comb. Insert the comb completely and align with the glass plate.
- 9 Let the stacking gel solution polymerize for 30 - 45 min. If the gel is subsequently used, carefully remove the comb by gently pulling it out and rinse the wells with H₂O or buffer. If the gel is used at a later time, keep comb inserted and store the gel cassette in a sealed plastic bag at 4 °C.

Further advice for hand gel casting

- Clean glass plates thoroughly with ethanol before using and avoid detergent residues.
- For optimal results, only use high quality reagents. Always prepare fresh APS solutions and avoid using TEMED solutions that are older than three months.
- Do not store gels for a long period of time. Do not freeze the gels.



3.2 PAGE System Operation

3.2.1 U Sealing Strips for Pre-Cast and Hand-Cast Gels

Ready-to-use pre-cast gels offer easier and faster handling, increased quality control and the possibility of storing gels for a longer period of time. The FastGene® PAGE Protein System is compatible with Pre-cast gels from different leading manufacturers (e.g. FastGene® gels, Bio-Rad TGX™ gels and ThermoFisher™ mini gels).

Compatibility of different pre-cast gels is assured by matching U sealing strips, which are placed as a sealing between the inner electrophoresis chambers (with / without electrodes) and the gels on both sides.

The FastGene® PAGE Protein System comes with three different U sealing strips to ensure maximum compatibility (see Figure 3). The short U sealing strip without a notch is used with 10 x 8 cm FastGene® Pre-cast gels. The short U sealing strip that contains a notch in the upper area of the seal is used with 10 x 8 cm Bio-Rad TGX™ gels and hand-cast gels. The long U sealing strip long contains additional sealing and is used with 10 x 10 cm ThermoFisher™ mini gels.

U sealing strip FastGene® (10 x 8 cm)	FastGene® Pre-cast gels
U sealing strip short for Bio-Rad TGX™ gels (10 x 8 cm)	Bio.Rad TGX™, Hand-cast gels
U sealing strip long for 10 x 10 cm gels	ThermoFisher™ mini gels



U sealing strip FastGene®

- 10 x 8 cm gels
- FastGene® Pre-cast gels



U sealing strip short

- 10 x 8 cm gels
- Bio-Rad TGX™
- Hand-cast gels



U sealing strip long

- 10 x 10 cm gels
- ThermoFisher™ mini

Fig. 4: U sealing strips compatibility with Pre-cast gels and Hand-cast gels



3.2.2 Gel Cassette Assembly

If two gels are used (or one gel and one Plastic dummy cassette), the gels should be placed into the **inner electrophoresis chamber with electrodes**.

If four gels are used (or three gels and one Plastic dummy cassette), the **inner electrophoresis chamber without electrodes** should be used additionally. Do not use the inner electrophoresis chamber without electrodes only for running one or two gels.

- 1 After inserting the compatible U sealing strip into the Inner electrophoresis chamber(s) (with / without electrodes), place the electrophoresis core onto a clean and flat desk.

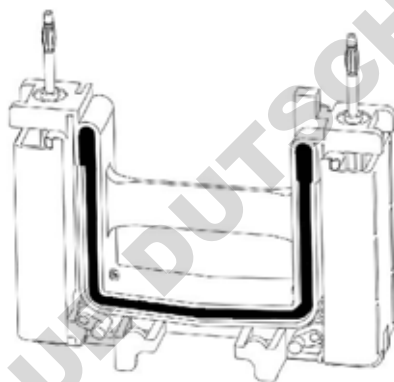

- 2 Remove the combs from the gels and place the pre-cast gels / hand-cast gels / plastic dummy cassette with the short glass / sample wells facing towards the inside of the Inner electrophoresis chamber. Rest the lower part of a gel cassette on the two steps positioned at the bottom part of the inner electrophoresis chamber and move the upper part of the gel cassette towards the U sealing strip.

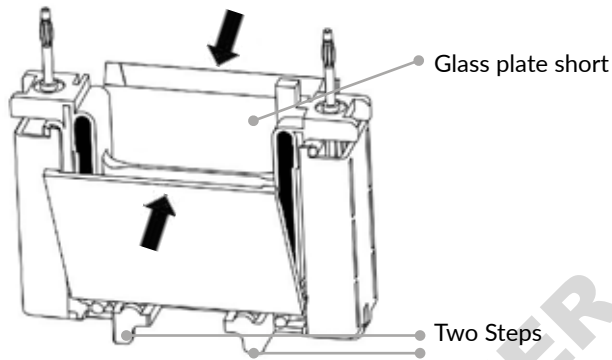

3

After positioning the gel cassettes in the inner electrophoresis chamber, move the two side clip fasteners on the left and right side of the inner electrophoresis chamber towards the inside. This secures the gel cassettes by pressing them against the U sealing strip. Closing the side clip fasteners also shifts the two moveable knobs at the bottom side of the inner electrophoresis chamber from underneath upwards and towards the gel cassette. The gel cassette now rests on the two moveable knobs and is pressed upwards. This additionally secures the glass plates and prevents buffer leakage.

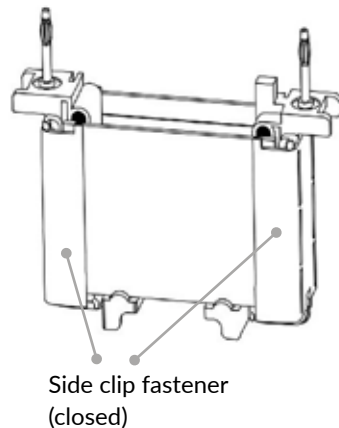
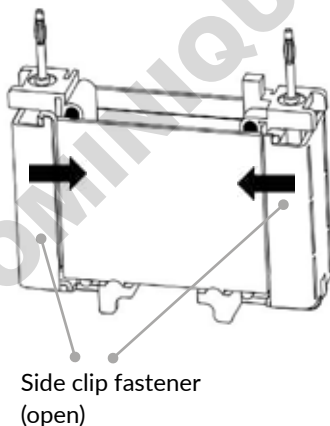



3.2.3 PAGE System Chamber Assembly

- 1 Put the assembled inner electrophoresis chamber(s) with gel cassettes into the FastGene® Gel/Blot chamber tank. Place the inner electrophoresis chamber with electrodes on the back side with two plastic humps. If used, place the inner electrophoresis chamber without electrodes on the front side. Make sure the anode (red) and cathode (black) of the Inner electrophoresis chamber are aligned with the anode (+) and cathode (-) symbols on the Gel/Blot chamber tank.

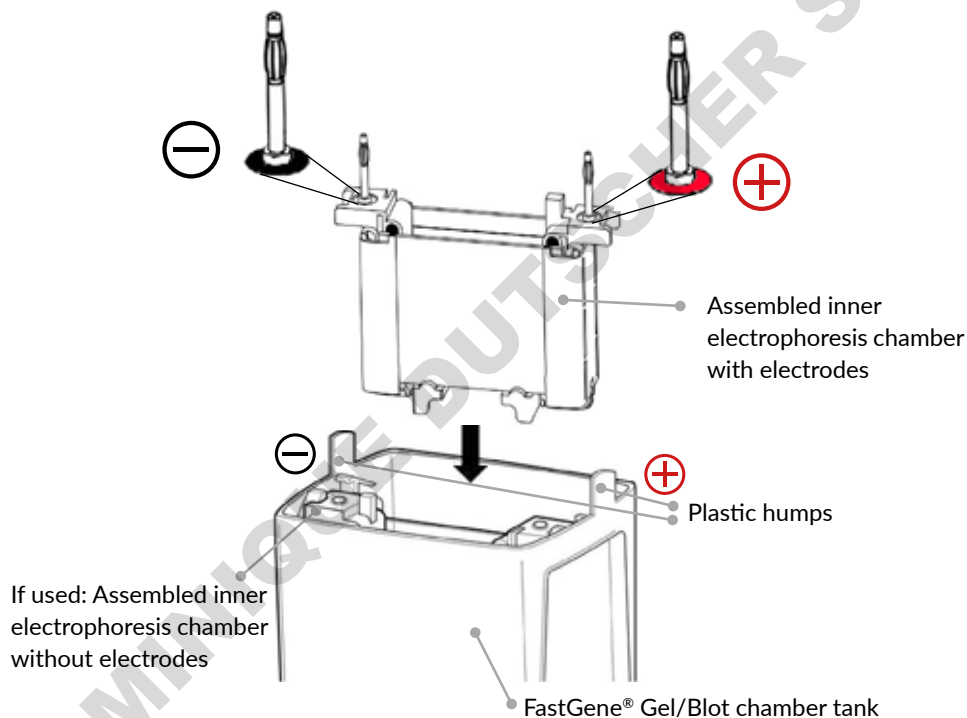

- 2 Fill the inner electrophoresis chamber(s) and Gel/Blot chamber tank with running buffer. A standard running buffer for SDS-PAGE is a Tris-Glycin-SDS buffer, pH 8.3.

Fill the inner electrophoresis chamber(s) almost completely with running buffer, until the buffer level is slightly under the edge of the gel cassettes.

Fill the outer Gel/blot chamber tank up to the indicator mark for 2 Gels (using one inner electrophoresis chamber) or 4 Gels (using two inner electrophoresis chambers).



3.2.4 Sample Preparation

There are many possibilities and no holistic or optimal approaches to prepare samples for PAGE. The preparation depends on the protein sample and desired analysis method. Each sample preparation protocol should be individually optimized and adapted. Nevertheless, there are some general points to consider when preparing samples for SDS-PAGE:

Cell Disruption:

If cell lysates are analyzed, an appropriate method for cell disruption should be selected. Depending on the used cell type milder or harsher disruption methods can be used.

Protein quantity:

For loading enough protein for detection, but not too much to overload the gel, it is important to determine the protein concentration before preparing SDS-PAGE samples. This can be executed by performing colorimetric protein assays. 10 - 20 μg of protein per well can be considered as a rough guideline.

Protein solubilization:

In SDS-PAGE, the detergent sodium dodecyl sulfate (SDS) is added for sample preparation. The harsh detergent leads to protein denaturation, unfolding and solubilization. Most SDS-PAGE loading buffers (e.g. Laemmli buffer) contain SDS and b-ME and can in many cases also be used as a cell disrupting agent. Cell disruption, protein denaturation and solubilization can be enhanced by shortly incubating the samples in SDS-PAGE loading buffer at 95° C for 5 min.

Additional agents:

Protein structures are build up by primary, secondary, tertiary and quartery protein interactions. Although SDS is a harsh detergent and in most cases breaks secondary, tertiary and quartery protein interactions, it is not sufficient to dissolve covalent disulfide bonds. The disruption of disulfide bonds is carried out by the addition of reducing agents such as DTT (dithiothreitol) or b-ME (beta-mercaptoethanol).



3.2.5 Sample Loading

The samples can be applied to the gel after sample preparation. Gel loading tips can help to dispense the sample evenly and simplify entering even small gel loading wells. Make sure to inject the sample slowly and let it sink from the pipette tip down to the bottom of the well. In addition, apply a protein marker to the gel in order to be able to estimate the size of the protein bands

The maximum gel sample well volumes of the FastGene® hand-cast gel set are depicted in the following table:

Number of Sample wells	Sample well width	Sample well volume		
		0.75 mm	1.0 mm	1.5 mm
10	5.1 mm	33 µl	44 µl	66 µl
15	3.4 mm	20 µl	26 µl	40 µl

Further advice for sample loading

- Centrifuge SDS-PAGE samples before loading, to sediment out small, insoluble particles and precipitates. Aspirate only the soluble supernatant of the SDS-PAGE sample to load the gel in order to avoid clogging the gel pores.
- Wash out the gel wells (also wells that will be kept empty) with running buffer before loading the samples to ensure an even buffer concentration in the wells and avoiding "smile" effects.



3.2.6 Performing Electrophoresis

- 1 After applying the samples and protein marker to the gel, put the FastGene® Gel/Blot chamber lid on top of the Gel/Blot chamber tank. It will only be possible to put the lid on the chamber tank if the inner electrophoresis chambers with / without electrodes are correctly positioned inside the chamber tank. Make sure the plastic humps of the Gel/Blot chamber tank go through the two narrow openings on each side of the lid.

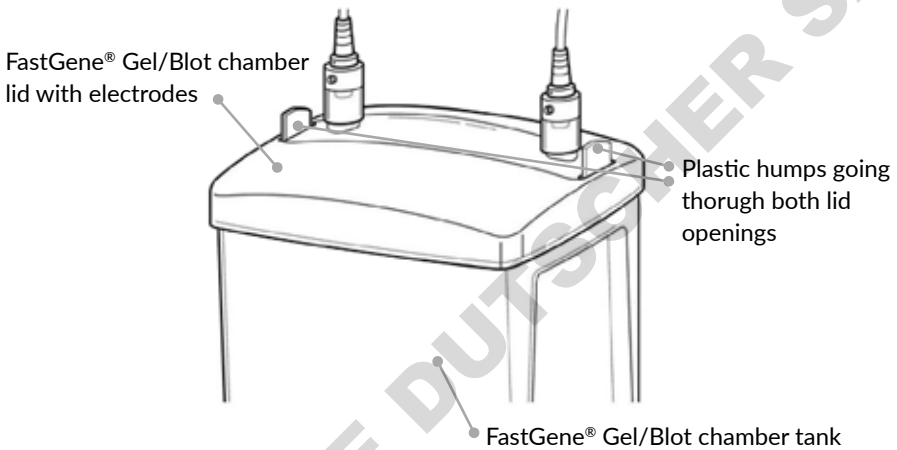

- 2 Connect the electrodes of the lid to an external power supply. Perform the electrophoresis with a constant voltage of 200 V for a time of 30 - 45 minutes to run 1-4 gels. The power is off when the upper lid is opened. Do not attempt to operate the electrophoresis system without the lid. Turn off the power of the external power supply and disconnect the electrodes, after the electrophoresis run is completed.
- 3 Open the lid, take out the inner electrophoresis chamber from the buffer tank and pour out the running buffer. Slide the side clip fasteners open and remove the gel cassettes. Separate the two glass plates of the gel cassettes and carefully take out the gel. The gel can now be put into a staining solution or used in further applications such as western blotting.
- 4 Do not reuse the electrophoresis running buffer. Discard the running buffer and clean the inner electrophoresis chambers, U sealing strips and the Gel/blot chamber tank with distilled water.



DOMINIQUE DUTSCHER SAS



4. TROUBLE SHOOTING

Hand-Gel casting:

Problem	Cause	Solution
• Leakage during casting	• Broken glass plate	• Ensure glass plates are faultless
	• Glass spacer and glass plate not aligned correctly	• Ensure the glass plates are correctly aligned
	• Sealing gasket has cracks	• Replace sealing gasket with a new one
• Gel sample wells not forming properly	• Catalyst not active	• Use a fresh catalyst solution (APS, TEMED) • Increase catalyst concentration by 20 %
	• Polyacrylamide Monomer solution not degassed	• Degas Polyacrylamide monomer solution
• Gel polymerization fails	• Catalyst not active	• Use a fresh catalyst solution (APS, TEMED) • Increase catalyst concentration by 20 %
	• Polyacrylamide Monomer solution not degassed	• Degas Polyacrylamide monomer solution
	• Low Temperature	• Cast Gel at room temperature
	• Use of reagents with poor quality	• Use high quality reagents
• Inhomogenous gel, polymerization too fast	• Too much catalyst added	• Decrease catalyst concentration (APS and TEMED) by 20 %
• Inhomogenous gel, polymerization too slow	• Catalyst not active	• Use a fresh catalyst solution (APS, TEMED) • Increase catalyst concentration by 20 %



Problem	Cause	Solution
• Gel too soft	• Acrylamide/Bis percentage too low	• Increase Acrylamide/Bis percentage
	• Use of reagents with poor quality	• Use high quality reagents

Sample loading:

Problem	Cause	Solution
• Sample floats out of well	• Sample Density too low	• Increase glycerol concentration to 10 % in sample to increase sample density
	• Sample well filled too fast	• Use gel loading tips, load the sample slowly and carefully

Gel Electrophoresis:

Problem	Cause	Solution
• No current flowing	• Too little running buffer in Inner electrophoresis chamber or Gel/Blot chamber tank	• Fill the inner electrophoresis chamber completely • Fill Gel/Blot chamber tank up to the indicator mark
	• Pre-cast gel still contains sealing tape	• Remove the sealing tape from the pre-cast gel
• Gel electrophoresis runs too fast	• Wrong running buffer concentration	• Check buffer concentration and make a new running buffer
	• Voltage too high	• Decrease voltage by 50 %



Problem	Cause	Solution
• Gel electrophoresis runs too slow	• Wrong running buffer concentration	• Check buffer concentration and make a new running buffer
	• Salt concentration in sample is too high	• Decrease salt concentration in sample
• Inner electrophoresis chamber buffer leakage	• Wrong PAGE system assembly	• Check PAGE system assembly, make sure the U sealing strip is entirely covered by the gel
	• Wrong / damaged U sealing strip	• Make sure to use a compatible U sealing strip • Check U sealing strips for cracks, replace if damaged

Protein separation:

Problem	Cause	Solution
• Diffuse bands	• Use of reagents with poor quality	• Use high quality reagents
	• High Temperature	• Decrease running voltage or run electrophoresis with external cooling
• Bands with "smile" effect	• High Temperature	• Decrease running voltage or run electrophoresis with external cooling
	• Too little running buffer	• Fill the Inner electrophoresis chamber completely with running buffer, make sure the wells are covered with running buffer
	• Different buffer concentration in wells	• Wash out gel wells with running buffer



Problem	Cause	Solution
<ul style="list-style-type: none">Bands with "smile" or "frown" effect	<ul style="list-style-type: none">Protein overload	<ul style="list-style-type: none">Reduce amount of loaded protein per well
	<ul style="list-style-type: none">Reagent concentration too high	<ul style="list-style-type: none">Check / reduce salt, detergent or solvent concentration in sample
	<ul style="list-style-type: none">High Temperature	<ul style="list-style-type: none">Decrease running voltage or run electrophoresis with external cooling
<ul style="list-style-type: none">Distorted bands	<ul style="list-style-type: none">Reagent concentration too high	<ul style="list-style-type: none">Check / reduce salt, detergent or solvent concentration in sample
	<ul style="list-style-type: none">Band diffusion before electrophoresis	<ul style="list-style-type: none">Reduce time between loading samples on gel and voltage application
	<ul style="list-style-type: none">Band diffusion in stacking gel	<ul style="list-style-type: none">Increase acrylamide percentage in stacking gel from 4 % to 4.5 %Increase voltage during stacking gel migration by 25 %
	<ul style="list-style-type: none">Gel interface uneven	<ul style="list-style-type: none">Decrease catalyst concentration (APS and TEMED) by 20 % to reduce polymerization rateCarry out stacking gel overlay carefully
<ul style="list-style-type: none">Vertical band streaking	<ul style="list-style-type: none">Protein overload	<ul style="list-style-type: none">Reduce amount of loaded protein per well
	<ul style="list-style-type: none">Precipitations in sample	<ul style="list-style-type: none">Remove precipitates by centrifugation before sample loading
<ul style="list-style-type: none">No protein migration in resolving gel	<ul style="list-style-type: none">Wrong charge of migrating protein (neutral or positive)	<ul style="list-style-type: none">Check pH of stacking gel, resolving gel and running gel buffer



5. WARRANTY

NIPPON Genetics EUROPE provides a product warranty to the purchaser against defects and/or incorrect material processing **for one year after the shipping date**. This warranty excludes damages resulting from shipping, misuse, carelessness, or neglect. NIPPON Genetics EUROPE's liability under the warranty is limited to the receipt of adequate evidence by the customer that the defect falls under the warranty conditions. All claims under this warranty must be submitted to NIPPON Genetics EUROPE within one year of delivery of the product to the customer.

6. CONTACT INFORMATION

NIPPON Genetics EUROPE GmbH
Mariaweilerstraße 28-30
52349 Düren, Germany

Tel: +49 2421 554960

Fax: +49 2421 55496 11

E-Mail: info@nippongenetics.de

For more detailed product information, contact details, questions, or trouble shooting please visit our website www.nippongenetics.eu or contact us via info@nippongenetics.de.

FastGene® is a registered trademark of NIPPON Genetics EUROPE GmbH.

DOMINIQUE DITSCHER SAS

