



KINEMATICA AG

Dispersing and Mixing Technology

MANUAL



System POLYMIX® PX-MFC 90 D Operating Instructions

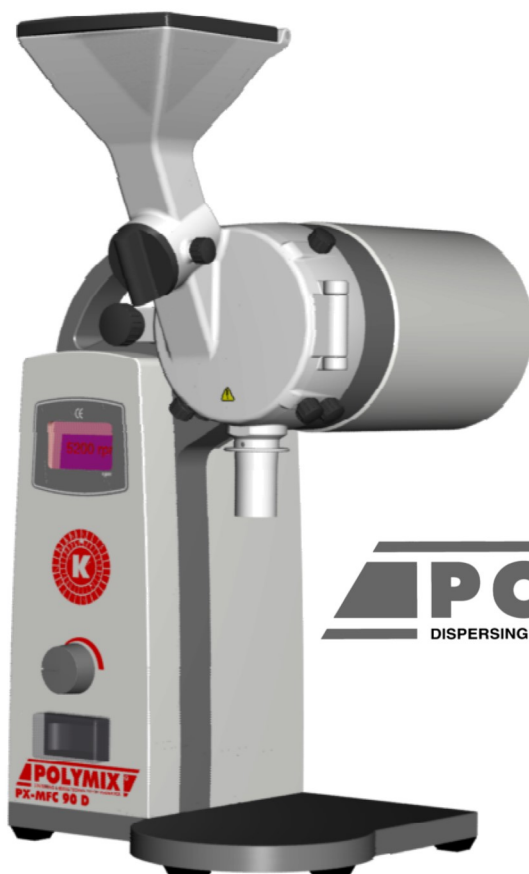

POLYMIX®
DISPERSING AND MIXING TECHNOLOGY BY KINEMATICA



Read manual before starting operation!



Voltage

- 100...120 V, 50/60 Hz
- 210...250 V, 50/60 Hz

Please check that the voltage is correct and corresponds with the nameplate on the back of the machine.

This is a quality product made by



KINEMATICA AG

Dispergiert- und Mischtechnik

Luzernerstrasse 147a
CH-6014 Littau-Luzern
Switzerland

Tel.: +41-41-259 65 65
Fax: +41-41-259 65 75
e-mail: info@kinematica.ch



CONTENT:

1	INTRODUCTION.....	3
1.1	OPERATING INSTRUCTIONS	3
1.2	ORGANISATIONAL MATTERS	5
1.3	WARNING NOTICES	6
2	SAFETY	7
2.1	SUMMARY	7
2.2	SAFETY CONCEPT	7
2.3	RESIDUAL DANGERS.....	10
2.4	WARNINGS.....	11
3	DESCRIPTION OF THE MACHINE	13
3.1	OVERVIEW	13
3.2	DRIVE UNIT	16
3.3	GRINDING ATTACHMENTS	16
3.4	TOOLS AND ACCESSORIES	18
3.5	TECHNICAL SPECIFICATIONS.....	19
4	INSTALLATION.....	20
4.1	UNPACK.....	20
4.2	START UP.....	20
4.3	EXCHANGE OF GRINDING ATTACHMENTS.....	23
5	MAINTENANCE.....	27
5.1	DRIVE SYSTEM.....	28
5.2	CLEANING & MAINTENANCE	28
5.3	SPARE PARTS LIST	32
6	TROUBLE SHOOTING	33
7	ACCESSORIES.....	34
8	WARRANTY	35
APPENDIX A.	DIMENSIONAL DRAWINGS	36
APPENDIX B.	PARTS LISTS.....	37



1 INTRODUCTION

This chapter gives information on the the structure of this document. It will assist you in making use of it and show how to find the required information quickly.

1.1 OPERATING INSTRUCTIONS

Please read through these operating instructions before switching on or attempting to use the equipment. They describe the use of the POLYMIX® PX-MFC 90 D, its installation and maintenance and the appropriate replacement parts and accessories.

They will help you avoid erroneous use and consequent damage. Although POLYMIX® machines are designed for ease of service, this does not release you from the obligation to inspect your equipment carefully and to clean it thoroughly.

KINEMATICA AG is a specialist manufacturer of machines and equipment for dispersion and mixing technology.

An important objective of these operating instructions is to fully inform you, the user, about the correct and safe use of our equipment.

In order to achieve this, it is essential that you should carefully study chapter 2, "Safety", and follow the instructions in this book.



1.1.1 RANGE OF VALIDITY

The information in these operating instructions relates to the POLYMIX® identified as follows:

Manufacturer: **KINEMATICA AG**, CH-6014 Littau / Luzern
Brand name: **POLYMIX®**
Product name: **POLYMIX® PX-MFC 90 D**

Order code	Identifier
35010020	Drive POLYMIX® PX-MFC 90 D, 115 V, with US-power cable, hammer-grinding attachment, tools
35010021	Drive POLYMIX® PX-MFC 90 D, 230 V, with EU-power cable, hammer-grinding attachment, tools
35010022	Drive POLYMIX® PX-MFC 90 D, 230 V, with CH-power cable, hammer-grinding attachment, tools
35010023	Drive POLYMIX® PX-MFC 90 D, 230 V, with GB-power cable, hammer-grinding attachment, tools
35010030	Drive POLYMIX® PX-MFC 90 D, 115 V, with US-power cable, blade-grinding attachment, tools
35010031	Drive POLYMIX® PX-MFC 90 D, 230 V, with EU-power cable, blade-grinding attachment, tools
35010032	Drive POLYMIX® PX-MFC 90 D, 230 V, with CH-power cable, blade-grinding attachment, tools
35010033	Drive POLYMIX® PX-MFC 90 D, 230 V, with GB-power cable, blade-grinding attachment, tools
35031001	hammer-grinding attachment for PX-MFC 90 D
35031002	blade-grinding attachment for PX-MFC 90 D
35080001	Stodger tool for stringy materials



1.1.2 TARGET AUDIENCE

These operating instructions are intended for all authorised users of our machines/equipment. We distinguish different user roles, taking account of the different demands placed on the user by the activity to be carried out.

You will find the definitions of user roles with the demands on the user in chapter 2, "Safety". You can fulfil one or more of these roles, provided that you meet the corresponding demands.

1.2 ORGANISATIONAL MATTERS

If you are unable to find the answer to any question in the operating instructions, please contact the equipment manufacturer directly.

1.2.1 LOCATION OF THE OPERATING INSTRUCTIONS

The operating instructions can only be of use to you if you always have them to hand. They should, therefore, always be kept at the place where the equipment is used.

1.2.2 MANUFACTURER AND CONTACT ADDRESS

KINEMATICA AG

Luzernerstrasse 147a

CH-6014 Littau / Lucerne

TEL: +41 41 259 65 65

FAX: +41 41 259 65 75

e-mail: info@kinematica.ch



1.3 WARNING NOTICES

Please be aware of the meaning of the following warning signs:



**ATTENTION DANGER / WARNING!
OBSERVE OPERATING INSTRUCTIONS.**



**ATTENTION!
DANGER OF ELECTRIC SHOCK.**



**ATTENTION!
WARNING OF HOT SURFACE.**



**ATTENTION!
MACHINE NOT SUITED FOR USE IN EX-AREAS**



2 SAFETY

This chapter is directed at all users of KINEMATICA laboratory equipment. It includes information on safe and optimum use.

2.1 SUMMARY

Any incorrect use of the installed equipment can be dangerous. Inadequately trained users can cause material damage and personal injury. This chapter informs you of the safety concept and the requirements for safe and optimum use of the equipment.

All those authorised to operate, service and repair the equipment are required to study chapter 2, "Safety".

2.2 SAFETY CONCEPT

The safety concept sets down the entitlement to use the equipment and the responsibilities of the individual users.

The machines and equipment are designed and constructed according to the state of the art and the recognised safety rules.

2.2.1 INTENDED USE OF THE EQUIPMENT

The equipment is designed and constructed for the following use:

- Cutting and milling of dry products in accordance with the technical specifications (see point 3.5) and compatibility with the materials coming into contact with the products.

If you use the equipment for any purpose other than those listed, the manufacturer cannot be held liable for any resulting damage.

2.2.2 IMPROPER USE

Any use other than the "proper use" without the written approval of the manufacturer or operation outside the technical limits of use is improper use.



2.2.3 USER ROLES

To guarantee safety, we place requirements on the users of the equipment that must be met without fail. Only persons meeting the requirements are authorised to work with the equipment.

We describe all those who work with the equipment as users. Since the requirements of these users are very much dependent on their activity, we distinguish the following user roles.

Contract partner:

The manufacturer can impose legal obligations on the contract partner when the equipment is purchased. The contract partner is obliged to ensure that the equipment is properly used.

Operating company:

The operating company ensures that the equipment is properly used and authorises persons who are entitled to work with the equipment in any one of the defined user roles. He is under the obligation to instruct the users.

Note:

Contract partner and operating company can be the same person.

Service technician:

The service technician is an employee of the operating company and looks after the equipment in special operating mode(s). He is a specialist with mechanical, electrical and electronic professional training. The service technician undertakes commissioning, decommissioning service and repair of the equipment. He must be appropriately trained to be able to carry out the service work required.

Operator:

The operator turns the equipment on and off. In the event of an alarm signal he informs the service technician.



2.2.4 DANGER AREA

System/equipment

The system danger area includes the whole system/equipment including the connecting lead and controls.

Proximity danger area

This refers to all areas within a defined distance of the equipment.

User danger area

This danger area includes all persons working with the equipment.

2.2.5 AREAS OF RESPONSIBILITY

In order that the system/equipment can be used safely and without risk, the users in various roles bear the responsibility for particular danger areas.

Contract partner:

The contract partner bears the responsibility for the “proximity danger area”.

Operating company:

The operating company bears the responsibility for the “user danger area”. Only those users may be authorised to operate the system/equipment who fulfil all requirements of the user roles concerned. In so doing, attention must be paid to the following points:

- It is to be ensured that all users of the system/equipment have fully read and understood chapter 2, “Safety” and act accordingly in a safety-conscious manner.
- It is to be ensured that no unauthorised person carries out work with the system/equipment.
- It is to be ensured that users are informed of the possible risks and dangers connected with the system/equipment.
- It is to be ensured that those being trained or engaged in general training are under the permanent supervision of a trained and authorised person.



Service technician:

The service technician bears the responsibility for the “system/equipment danger area”. He ensures that the system/equipment is at all times free from technical faults, safe and functions correctly.

2.2.6 GENERAL SAFETY RULES

Observe the following general safety rules:

- follow these operating instructions,
- in addition, observe the legal obligations and requirements for accident prevention and environmental protection of the country in which you operate the equipment,
- do not make any modifications to the equipment without the written authorisation of the manufacturer,
- only original replacement parts may be used for repairs,
- before any service work on the equipment, it must be ensured that the electrical supply is switched off,
- after any service, maintenance or repair work has been carried out on the system/equipment, it must be given a test run by the service technician.
- depending on the place at which it is installed, circumstances may require that hearing protection is worn when remaining in the vicinity of the equipment for long periods.

2.3 RESIDUAL DANGERS

When the system/equipment is used in accordance with rules and regulations, residual dangers are minimal.

Residual danger	Remedy
Tripping over connecting cables	Adequate installation
Breaking of glass containers	Wear eye protection. Close lid.
Product spurting out	
Damage to hearing by continuous exposure to noise	Wear ear protection according to duration and nature of task.
Tilting of machine	Use non-slip, sturdy and horizontal base pad.





AN EXPERT ELECTRICIAN MUST CARRY OUT ALL ELECTRICAL INSTALLATIONS

2.4 WARNINGS

	<ul style="list-style-type: none">• Make sure that the voltage of electric power source corresponds with machine.• Exchange grinding geometries only after electric power supply has been disconnected..• The electric power supply system, to which the machine is connected, must comply with the requirements stipulated on the nameplate in order to ensure a flawless functioning.
	<ul style="list-style-type: none">• If hazardous chemicals or harmful materials can impact the environment or the usage of the equipment, adequate corrective action has to be taken.
	<ul style="list-style-type: none">• During longer operation and high load the grinding chamber can warm up significantly – risk of light burns..
	<ul style="list-style-type: none">• The machine must not be operated in explosion-prone rooms (highly flammable gases, fluids, solids or dust in the environment)• Make sure that during the grinding of certain products no explosive dust atmosphere is generated. If strong formation of dust occurs during grinding, work under extractor hood

WARNINGS: To be continued on next page



WARNINGS: continuation

	<ul style="list-style-type: none">• Only service specialists authorised by KINEMATICA AG may open the machine.• The areas around the ventilation grille and the ventilation slots at the back of the machine must always remain unobstructed in order to ensure efficient cooling. If cooling is not sufficient, performance will decrease.• The machine has to be installed in a way that no dirt or liquid can enter via the ventilation slots.• Only dry, preferably non-fatty products may be ground.• Exchange grinding geometries only after electric power supply has been disconnected.• Make sure that the grinding geometries are thoroughly cleaned after each usage.• The grinding chamber must not be opened during operation.• For the feeding of stringy materials only the optional tamper (<i>order No. 35080001</i>) may be used. Using other objects may cause destruction of the grinding unit and/or injuries.
	<ul style="list-style-type: none">• <i>Never</i> manipulate with hands or tools in/around the open grinding chamber while electric power cable is connected.• <i>Never</i> grab down into the open hopper.
	<p>Products made by KINEMATICA AG comply with all established and relevant CE-regulations; they carry the CE-label and are delivered with a corresponding declaration of conformity.</p>



3 DESCRIPTION OF THE MACHINE

The PX-MFC 90 D complies with all established and relevant CE-regulations, it carries the CE-label and is delivered with a corresponding declaration of conformity.

3.1 OVERVIEW

The POLYMIX[®] PX-MFC 90 D is a lab mill, suited for grinding batches of dry substances. By exchanging the grinding geometries the mill can be converted into a hammer mill or a cutting mill.

The mill is not designed for continuous operation.

For a serviceable system you need to have:

- **The drive unit PX-MFC 90 D with power cable**
- **A milling-set (hammer mill set or cutting mill set)**
- **A sieve**
- **Collecting basin**
- **Power supply according to nameplate**

On the following page you find a picture of the complete system PX-MFC 90 D with legend and explanation of components.



MAKE SURE THAT ONLY DRY SUBSTANCES WITH A FAT CONTENT AS LOW AS POSSIBLE ARE GROUND. HIGHLY HUMID OR FATTY SUBSTANCES CAN CAUSE PLUGGING AND ACCUMULATION OF MATERIALS AT THE SIEVE AND THE GRINDING GEOMETRIES.

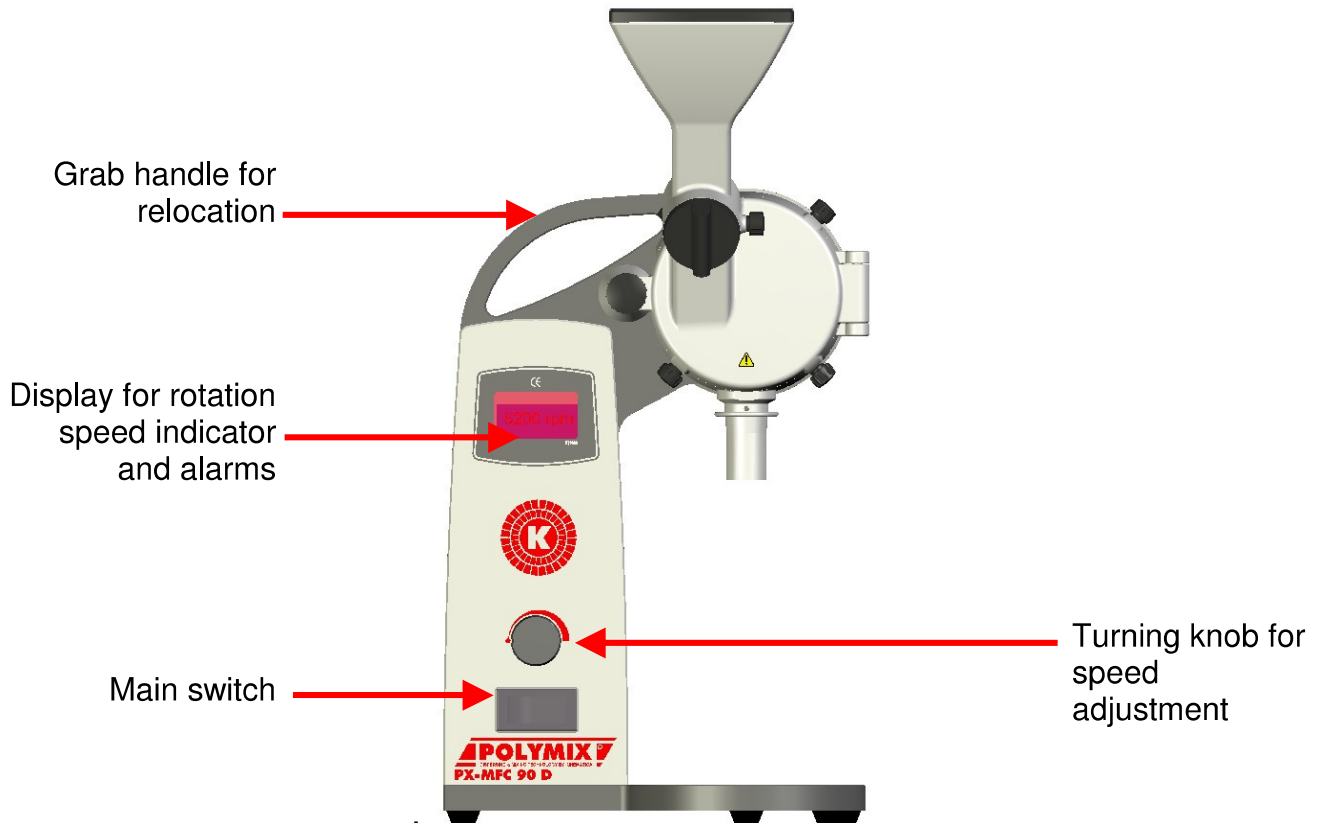

Fig. 1

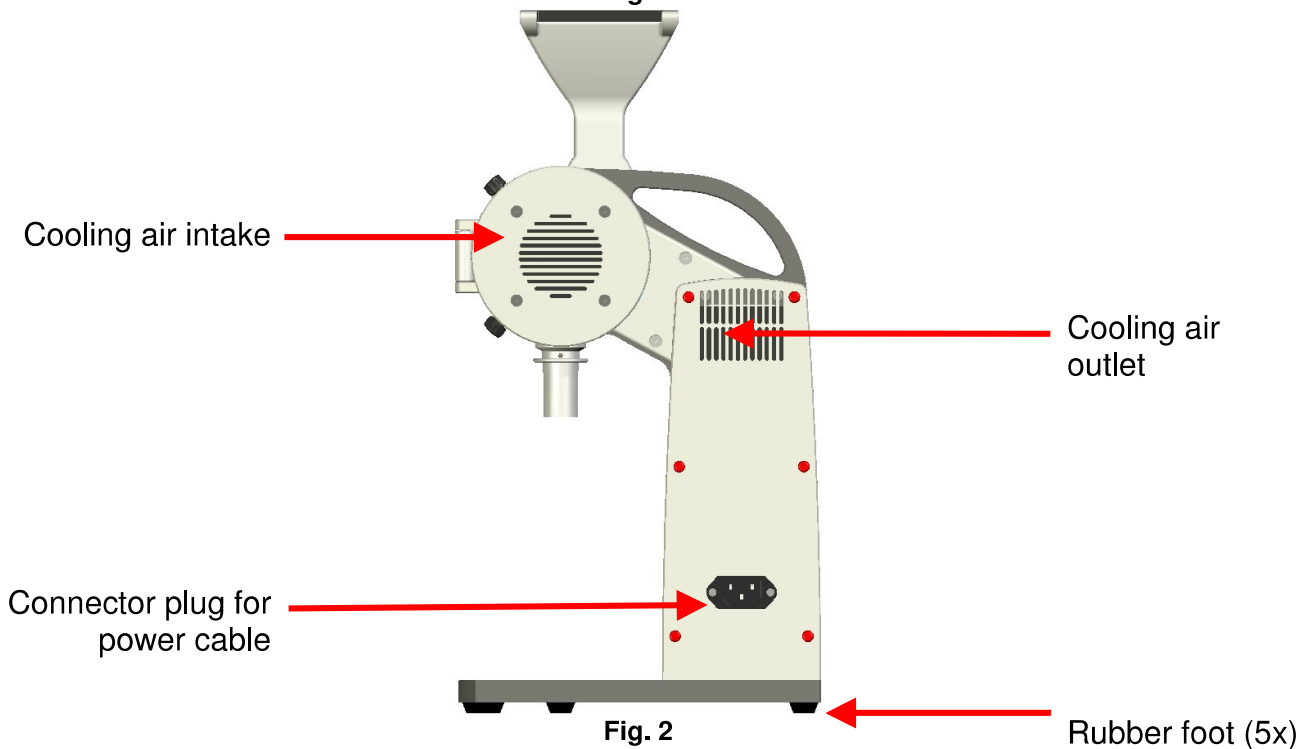
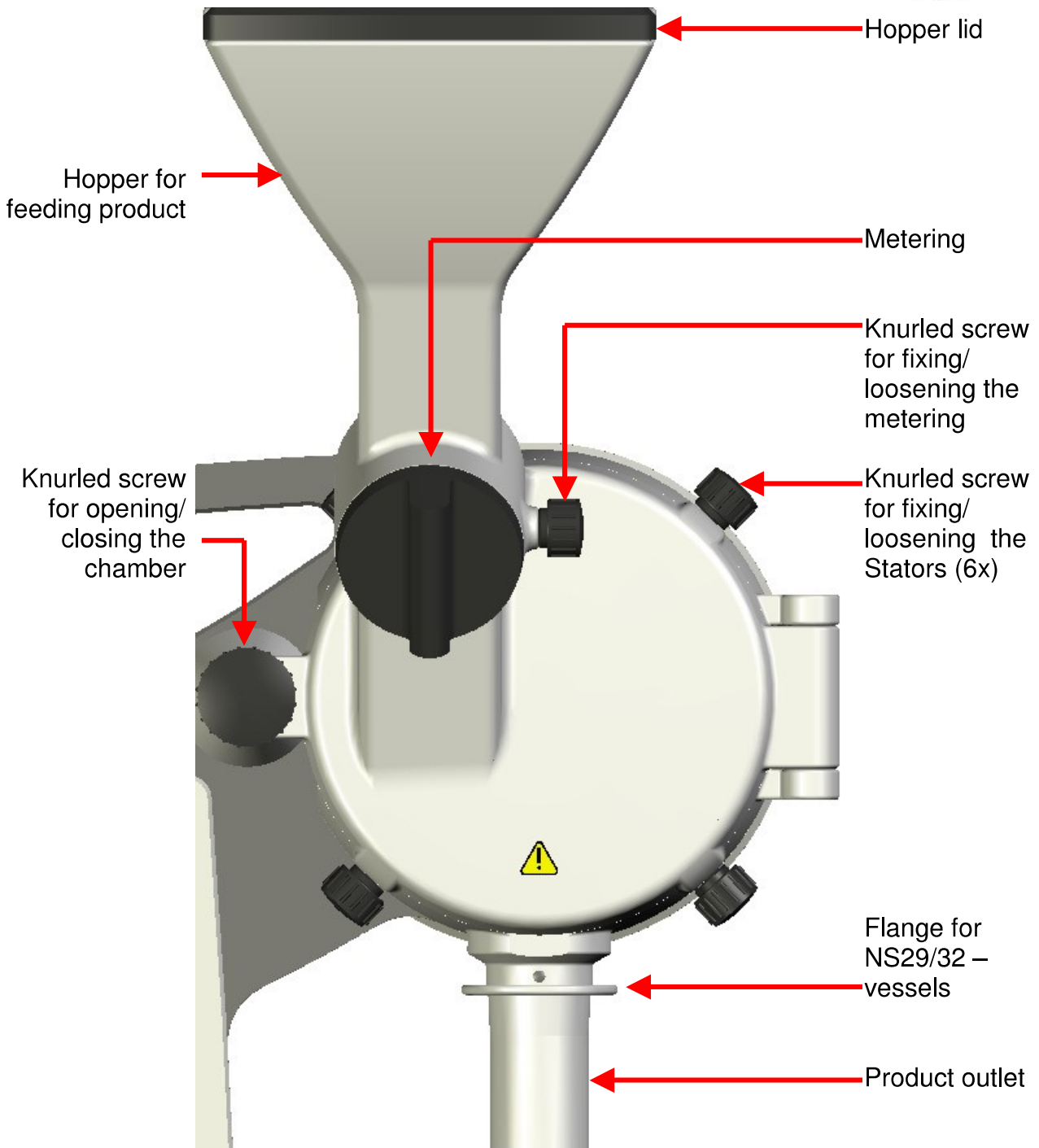

Fig. 2





3.2 DRIVE UNIT

The drive unit PX-MFC 90 D is equipped with a strong 1000 W motor and is switched on via the main switch on the front side of the machine. The machine disposes of an integrated electronic control system. Rotating speeds between 0 – 6000 rpm can be set. Maximum power is reached between 4500 and 5000 rpm.

The electronic control system disposes of safety functions, which induce an emergency shutdown in case of overheating or jamming of the drive unit, along with a corresponding alarm on the display. After an emergency shutdown the machine has to be restarted. The unit is also equipped with a safety function which prevents the motor getting started when the milling door is still open – The milling chamber has to be closed using the knurled screw to start the motor

A detailed list of these error messages and remedies can be found in chapter 6 "TROUBLE SHOOTING"

3.3 GRINDING ATTACHMENTS

For the grinding process there are 2 different grinding attachments as interchangeable kits.

Hammer-grinding attachment (Order-no. 35031001)

Fig. 3

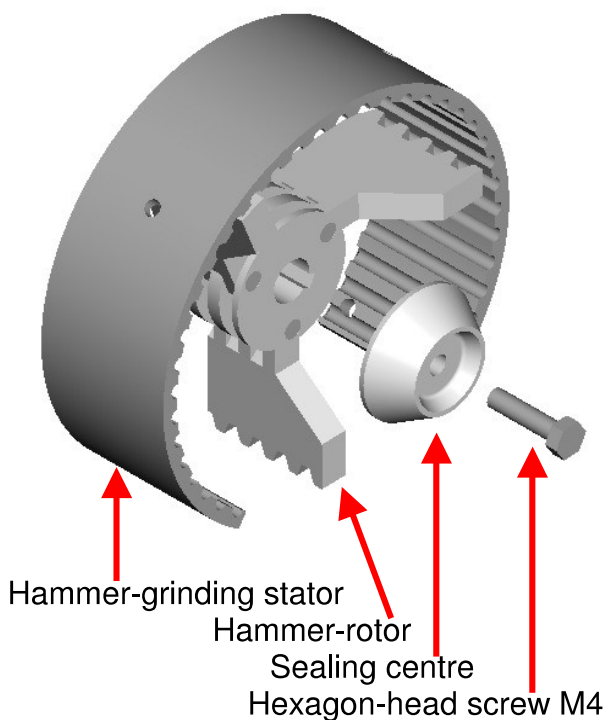

Blade-grinding attachment (Order-no. 35031002)

Fig. 4

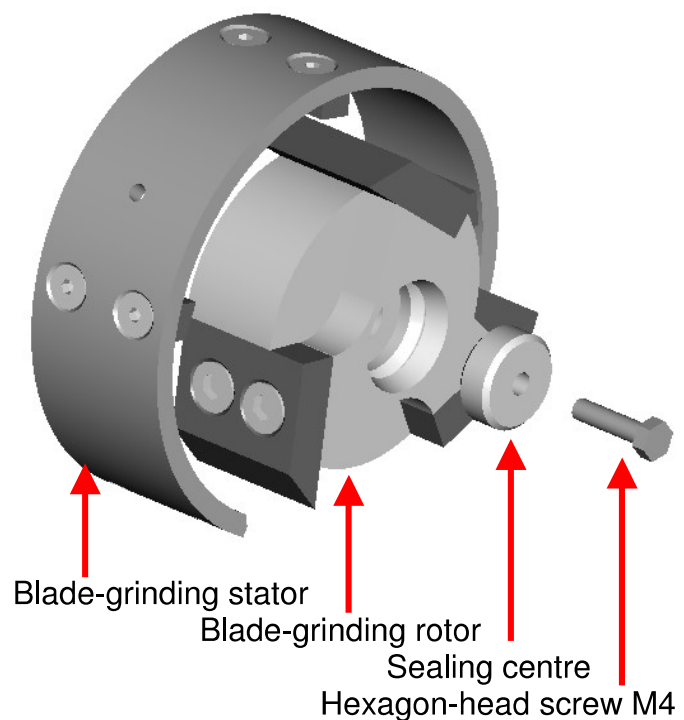



It has to be assured that the Blade-grinding stator will be mounted in the right orientation – see the following two pictures “right” & “wrong” mounting. Wrong mounting of the Blade-grinding stator will damage the motor shaft due wedge effects.

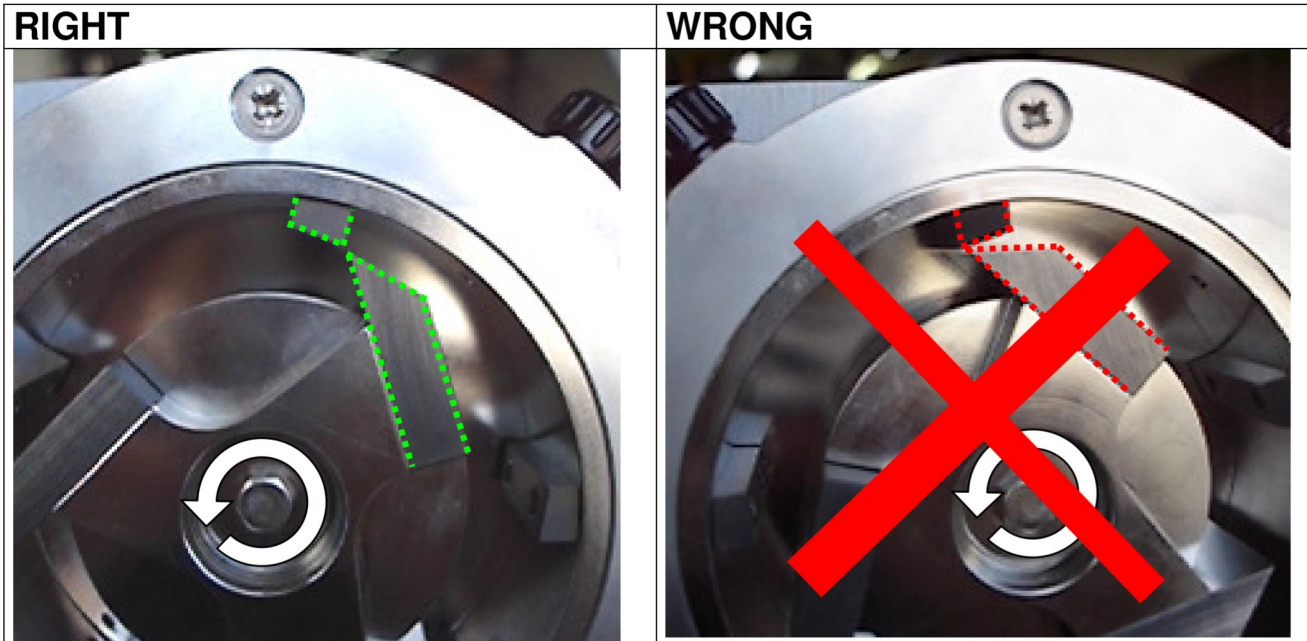



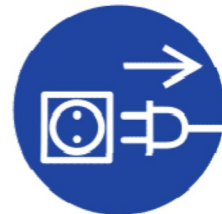





ATTENTION!
DURING DETACHING, EXCHANGING
OF UNITS THE DRIVE MUST BE
DISCONNECTED FROM POWER
SUPPLY.





**DURING LONGER OPERATION AND HIGH LOAD BOTH
THE COUPLING AND THE DISPERSION UNIT CAN
HEAT UP SIGNIFICANTLY - RISK OF BURNS.**

**3.4 TOOLS AND ACCESSORIES**

The mill is shipped with complete set of tools for dismounting, maintaining and cleaning. For dismantling of the blade-grinding rotor a special extractor tool is provided. Please see tables below.

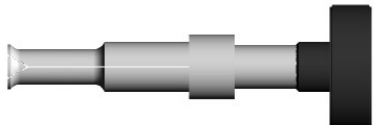
General tool set				
Identifier	Item-no.	Purpose	dimension [mm]	Picture
Socket key	9341185	Dismantling of the rotor	110 x Ø6/7	
Rotating pin	9341186	Dismantling of the rotor	Ø6 x 160	
Extractor hook	9754564	Dismantling of the stator	80 x 140	
Hex wrench	9951174	Dismantling of the rotor insert plate	Wrench size 2.74	
Brush	9341435	Cleaning	-	
Scratcher	9341436	Cleaning	-	
Pull out hook	9341437	Dismantling of the sieve	-	
Needle	9341438	Cleaning of sticking products	-	

Tool for blade-grinding attachment				
Identifier	Item-no.	Purpose	dimension [mm]	Picture
Inboard-extractor	9754548	Dismantling of the blade grinding rotor	146 x Ø50	
Hex wrench	9300112	Dismantling of the rotorblades	Wrench size 3	
Hex wrench	9300117	Dismantling of the statorblades	Wrench size 2.5	



Provided accessories				
Identifier	Item-no.	Purpose	dimension [mm]	Picture
Rack with drawer for 12 tubes & tools	9609114	Support for tubes	245 x 135 x 84	
Set of tubes (12 pc.)	9341439	Collecting milled material	Ø22 x 125	

3.5 TECHNICAL SPECIFICATIONS

Drive unit PX-MFC 90 D	
Motor	Three-phase a.c. motor
Power supply	210...250 V, 50/60 Hz 100...120 V, 50/60 Hz
Max. speed	6'000 rpm
Max. Tip speed	Approx. 22 m/s With hammer- or blade-grinding attachment
Max. granular size suitable for grinding	Hammer attachment : approx. 15 mm (spherical) Blade attachment: approx. 15 mm, at any length
Max. input power	1'000 W
Max. output power	600 W
Noise emission at max. speed	approx. 72 dB(A) (no load)
Ambient temperature	0 – 40 °C
Relative humidity	95% max.
Ingress Protection	IP 20
Standards	EMV acc. to IEC/EN 61000-6-2 / EN 61000-6-3 safety acc. to IEC/EN 61010-2-51
International Protection Class	IP 20
Duration of service	60%(S3): 10 min operation / 6 min idle
Dimensions	see appendix
Weight	12 kg



4 INSTALLATION

4.1 UNPACK

Open the transport box and check whether contents are consistent with bill of delivery.



CHECK ALL PARTS FOR POSSIBLE TRANSPORT DAMAGES. IMMEDIATELY REPORT ANY INCONSISTENCY OR ERROR DIRECTLY TO US OR YOUR SPECIALIST DEALER.

4.2 START UP

The drive unit is delivered ready-to-use with mounted grinding geometry. Only the supplied power cable needs to be plugged into the connector plug on the backside of the machine.

- Insert the desired sieve into the process chamber. Proceed as shown in the following images.

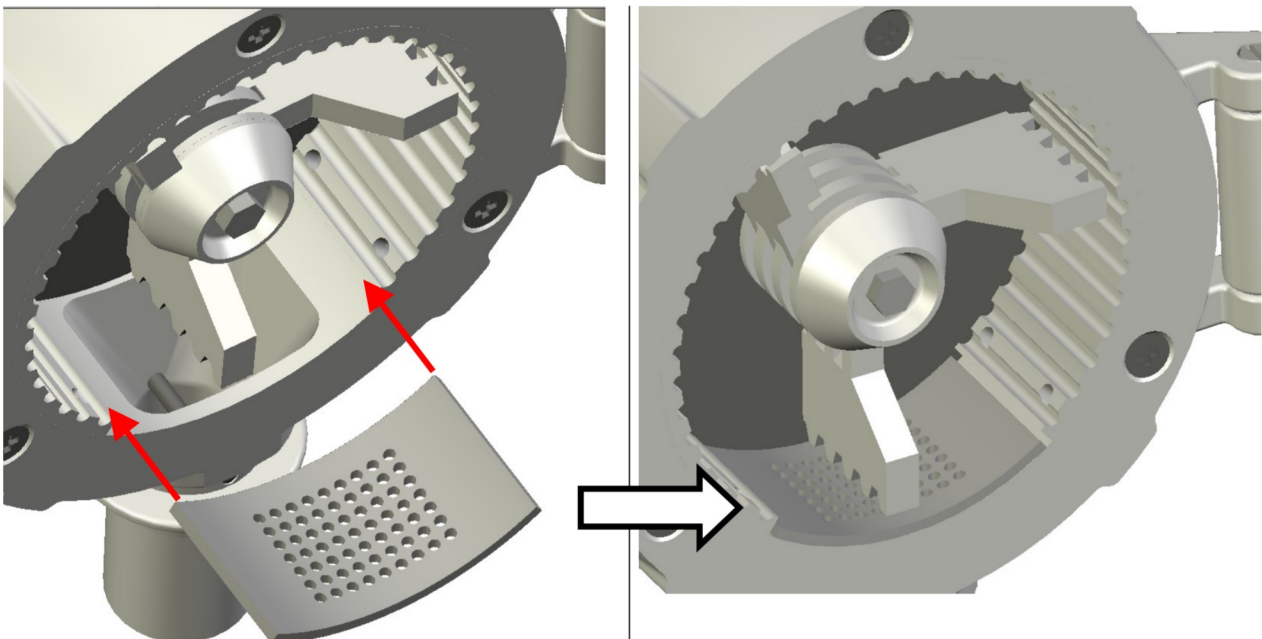



ASSURE THAT THE SIEVE IS PLACED INTO GROVE OF THE STATOR CORRECTLY AND NOT JUST PLACED ON THE STATOR.

SEE IMAGE BELOW.

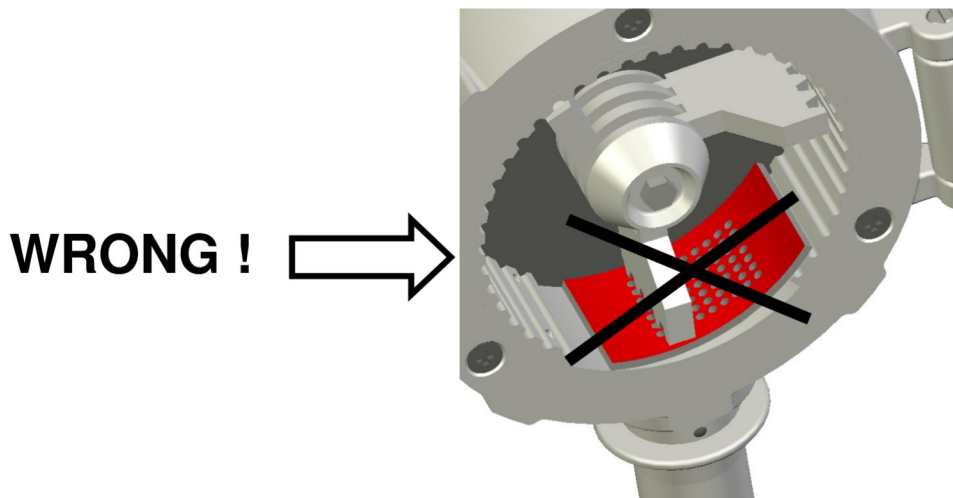

- Check voltage on the basis of nameplate
- Plug in power cable
- Switch on main switch
- Shut feeding channel with metering.
- Fill hopper with product.
- Place collecting basin under outlet.
- Set desired rotating speed.
- Start dosing product.

The following table offers a guideline regarding which milling set is best suited for which product.

Hammer-grinding attachment	Blade-grinding attachment
<ul style="list-style-type: none"> • Hard, dry cereal grains like corn • Rock substance • Pebbles • Dry beans • Salt • Coffee 	<ul style="list-style-type: none"> • Dry grass, hay • Paper scraps • Fish bones • Fish fins • Plastic pellets with portions of glass fibres • Wood chips



WHEN GRINDING HARD MATERIALS ASSURE THAT ITS HARDNESS DOES NOT EXCEED MOHS 6 (APPROX. ROCKWELL-HARDNESS 58). WHEN HARDER MATERIALS SHALL BE GRINDED, PLEASE CONTACT KINEMATICA AG.



4.3 EXCHANGE OF GRINDING ATTACHMENTS

Dismounting/Mounting of the hammer-grinding attachment

Make sure that the mill is switched off and the power cable disconnected before you start dismounting/mounting.

First, pull out a possibly inserted sieve.

Lock the hammer-rotor from below with the supplied rotating pin (1).

With the mandrel (3) inserted into the socket wrench (2), loosen the screw

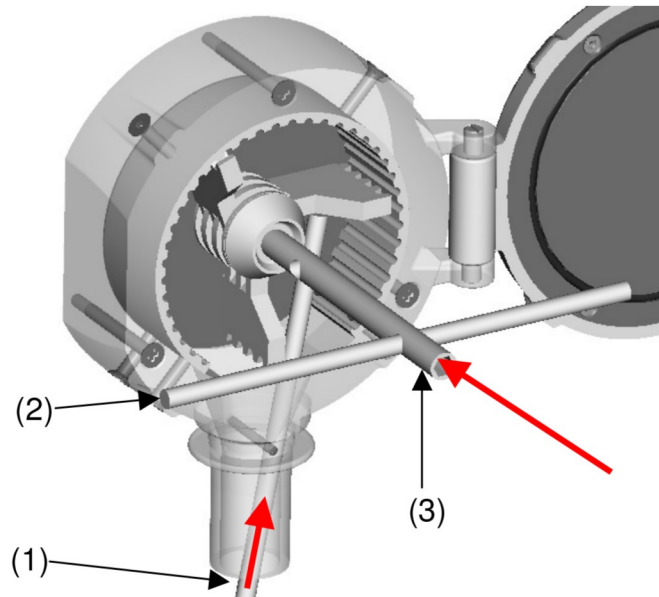

Fig. 5

Loosen the remaining screws according to the picture and remove first the rotor and then the grinding ring (stator).

If the grinding ring is stuck, use the supplied extractor hook in order to grip the grinding ring at the inside thread and pull it out. Please see Fig. 12, 13 & 14 for proper proceeding)

For mounting proceed in reverse order.

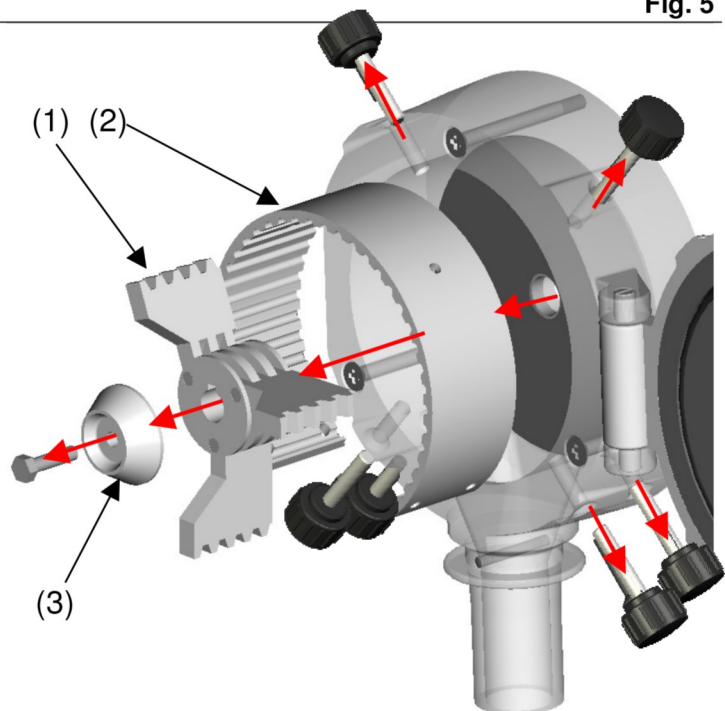

Fig. 6



Dismounting/Mounting of the blade-grinding attachment

Make sure that the mill is switched off and the power cable disconnected before you start dismounting/mounting

First, pull out a possibly inserted sieve.

Lock the rotor from below with the supplied rotating pin (1).

With the mandrel (3) inserted into the socket wrench (2), loosen the screw.

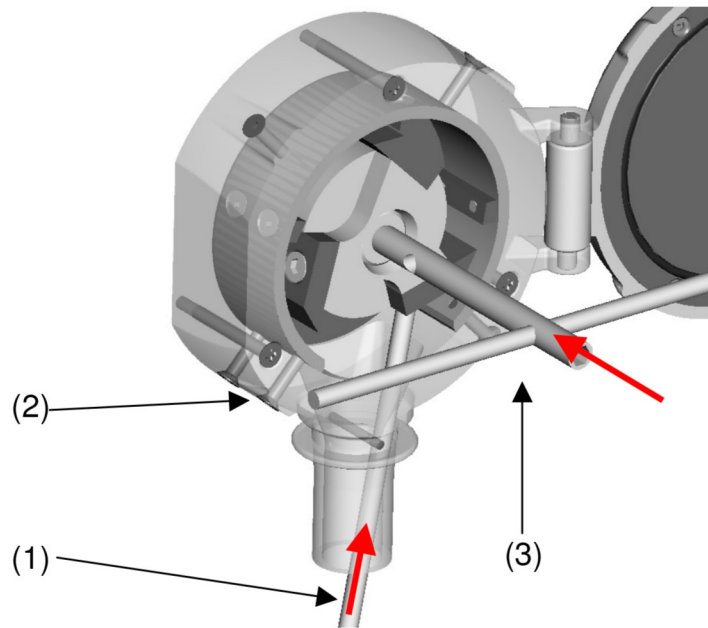

Fig. 7

Loosen the remaining screws according to Fig 8 and remove first the rotor and then the stator.

Use the supplied extractor tool in order to grip the rotor at the inside groove and pull it out. As shown in Fig. 9 on the next page.

Use the supplied extractor hook tool in order to grip the stator at the inside threads to pull it out. As shown in Fig. 9 on the next page.

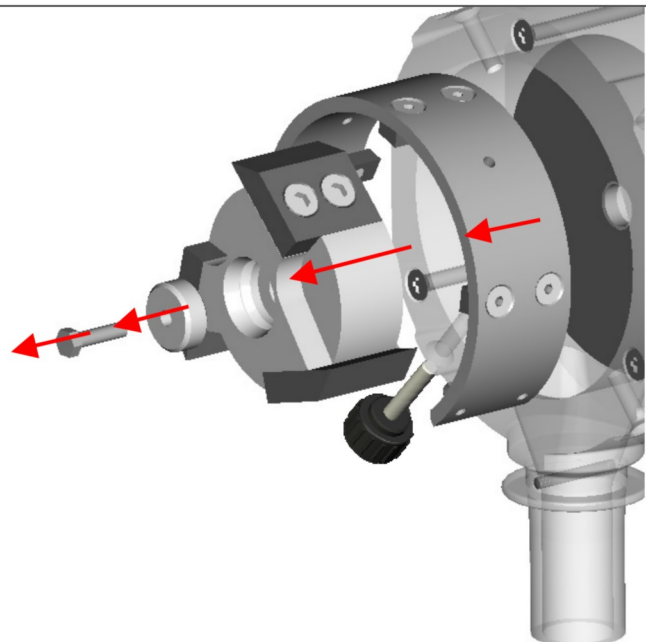

Fig. 8



Place the extractor (1) in the groove. Afterwards use the rotating knob (2) so that the lips of the extractor grab the rotor.

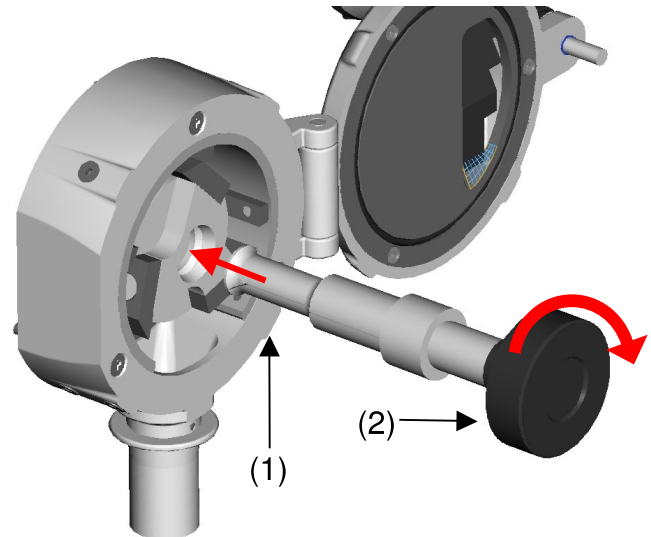

Fig. 9

When the rotor is grabbed, pull out the extractor with rotor, as shown in Fig. 10 and 11.

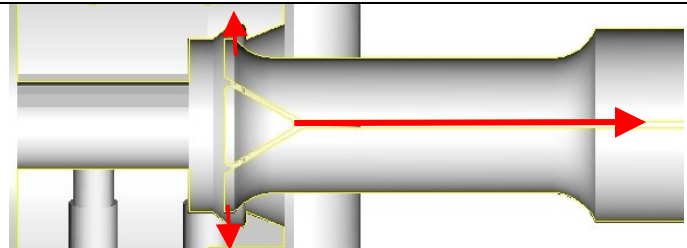

Fig. 10

Always use the extractor in your hands to dis/mount the blade-grinding rotor.

For mounting proceed in reverse order.

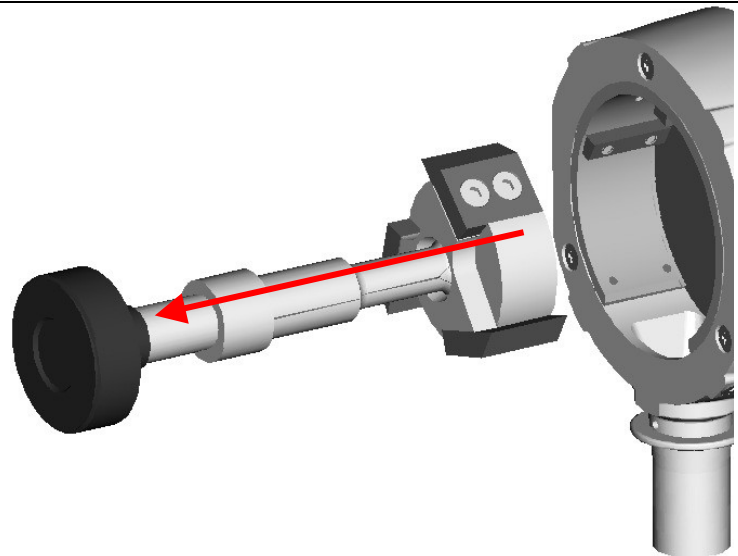

Fig. 11



Both blade- and hammer-grinding stator should be removed using the extractor hook.

Place the extractor hook (1) in the inside threads, as shown in Fig. 12 & 13

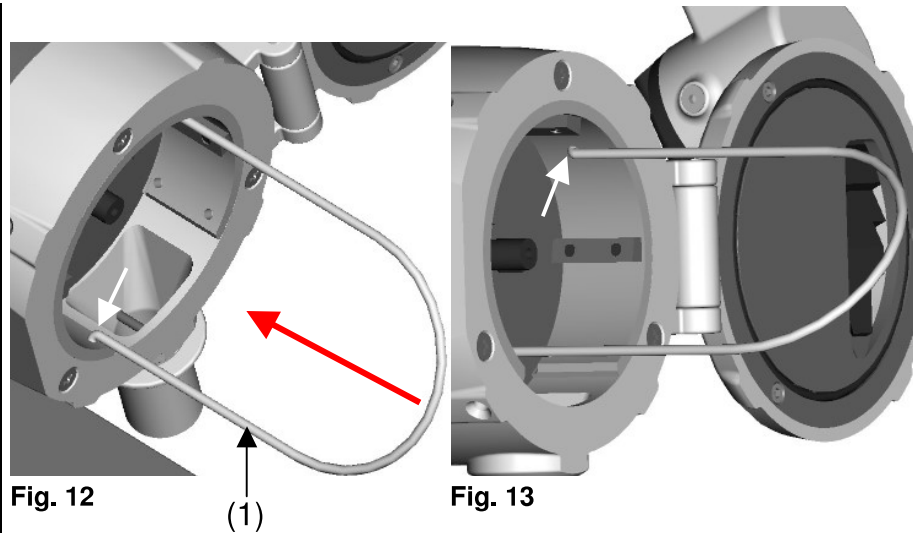

Fig. 12

(1)

Fig. 13

When both hooks are inside the threads, pull out the stator using both hands, as shown in Fig. 14.

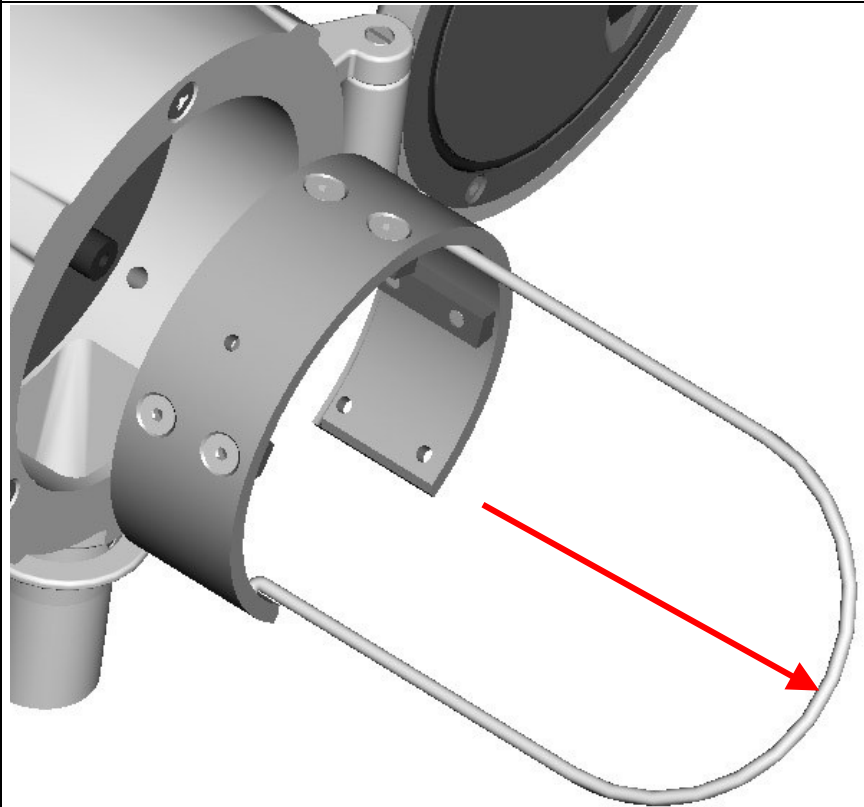
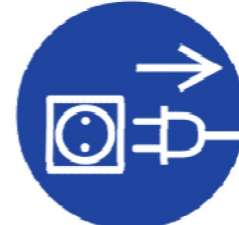

Fig. 14



ATTENTION!
DURING DETACHING, EXCHANGING OF GRINDING GEOMETRIES THE DRIVE MUST BE DISCONNECTED FROM POWER SUPPLY.



DURING LONGER OPERATION AND HIGH LOAD THE GRINDING CHAMBER CAN HEAT UP SIGNIFICANTLY - RISK OF BURNS.



MAKE SURE THAT GRINDING GEOMETRY GETS CLEANED THOROUGHLY AFTER EACH USAGE.

NEVER TOUCH A ROTATING ROTOR OF THE GRINDING GEOMETRY. HIGH RISK OF INJURY.

5 MAINTENANCE

Your POLYMIX[®] machine is easy to maintain; nevertheless a sound inspection and a thorough cleaning are indispensable.



THE MACHINE MUST BE DISCONNECTED FROM THE ELECTRICAL POWER SOURCE DURING THE FOLLOWING ACTIVITIES IN ORDER TO PREVENT INJURIES TO PERSONAL AND/OR DAMAGES TO THE MACHINE:

- EXCHANGE/REMOVAL OF GRINDING ATTACHMENTS
- CLEANING OR MAINTAINING THE MACHINE

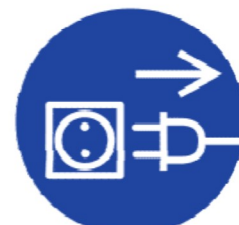



5.1 DRIVE SYSTEM

The drive unit PX-MFC 90 D is maintenance-free under normal working conditions. Parts as bearings are subjected to normal wear.

We strongly recommend to let service or repairs of the drive unit be performed only at authorised KINEMATICA service locations or directly at KINEMATICA, where original spare parts are available.

Any changes that are not authorised or any manipulation will result in immediate cancellation of the warranty.

5.2 CLEANING & MAINTENANCE

Dafür vorgesehene Werkzeuge: siehe Kapitel 3.4



ATTENTION!
DURING MOUNTING/DISMOUNTING PLEASE
MIND SHARP EDGES AND TEETH AT GRINDING
GEOMETRIES - RISK OF CUTTING.



5.2.1 Hammer-grinding attachment

- | | |
|---------|---|
| Stator: | <ul style="list-style-type: none">• Dirty grooves can be cleaned with supplied scratch-out tool.• Cleaning in ultrasonic bath is recommendable• The stator can also be cleaned with water. Important is a sound drying directly afterwards in order to prevent possible formation of rust.. |
| Rotor: | <ul style="list-style-type: none">• The same recommendations apply. |



Dismounting/Mounting of the hammer-grinding rotor

Push out the pins (2) of the center (1)

Mounting in reverse order

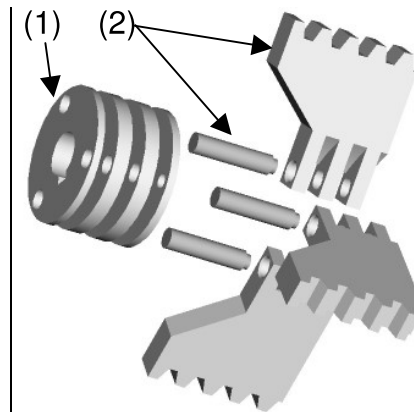

Fig. 15

5.2.2 Blade-grinding attachment

- Stator:
- Dirty grooves can be cleaned with supplied scratch-out tool and a needle.
 - The 6-edge-depressions of the screws can also be cleaned with the needle.
 - Cleaning in ultrasonic bath is recommendable.

- Rotor:
- The same recommendations apply.

Dis- / Assembling of the blade grinding attachment

Unscrew (5,6). the rotor- and stator-blades (1,2) very carefully.

When mounting the stator-blades again, assure that the cutting edges are directed clockwise.

When mounting the rotor-blades again, assure that they will be pressed against the wall of the rotor(3) while fastening the screws (5).

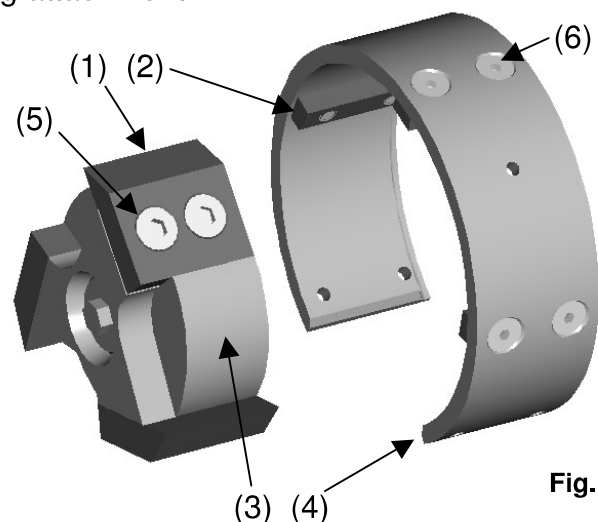

Fig. 16



5.2.3 Grinding chamber

The grinding chamber can be dismantled for cleaning purposes. Mounting/dismounting is described below:

First remove the grinding rotor as described under 4.3.

Loosen the 3 screws (1). The chamber can be removed.

Subsequently the insert plate (2) and the felt seal (3) can be removed.

For remounting proceed in reverse order.

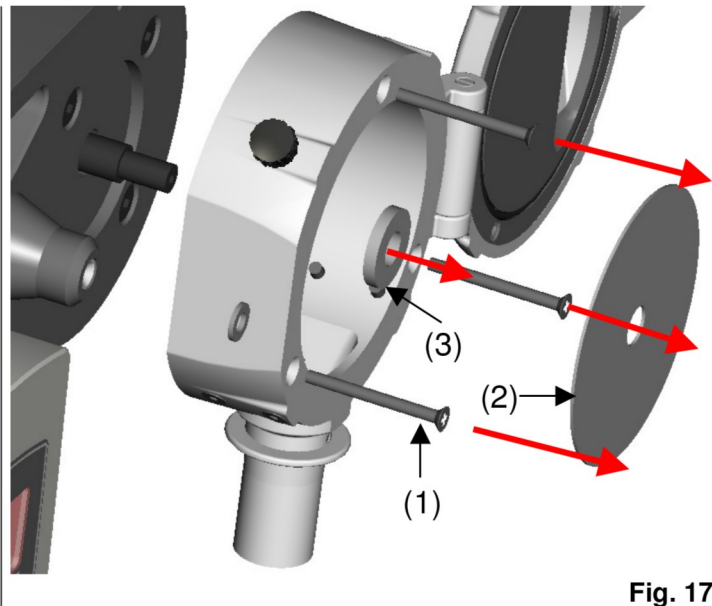

Fig. 17

The grinding chamber can be cleaned with water and in the ultrasonic bath. Make sure that chamber is completely dry before it is remounted in order to prevent the formation of fit corrosion.



5.2.4 Gate with hopper

The gate with integrated hopper can be dismantled for cleaning purposes. Mounting/dismounting is described below:

Dis/mounting of the rotary slide

Dismantle the screw (1) using the supplied hex wrench and pull out the rotary slide (2). Remove the O-ring (3).

Rotary slide and o-ring can now be cleaned /replaced.

For the mounting please proceed in reverse order.

When mounting the rotary slide, assure that the groove in the slide is adjusted like in Fig. 15.

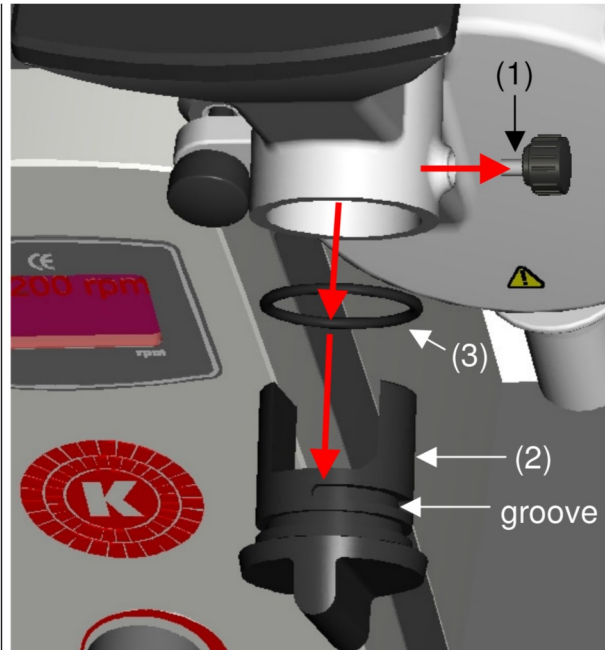

Fig. 18

Dis/mounting of the guard plate in the gate

Dismantle the screws (1) using the supplied hex wrench. Remove the plate (3) and the O-ring (2)

O-Ring and plate now be cleaned/ replaced.

For the mounting please proceed in reverse order.

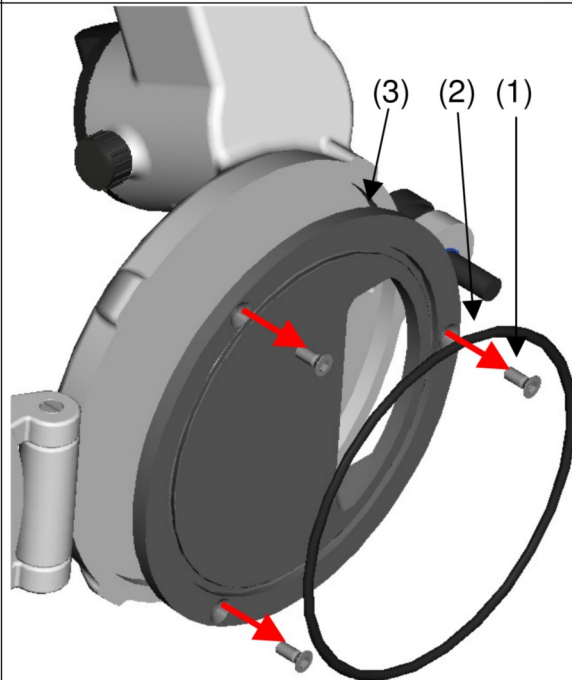

Fig. 19



5.3 SPARE PARTS LIST

The spare parts list is separated according to the assemblies: drive, hammer-grinding attachment and blade-grinding attachment. For ordering spare parts please advise **assembly**, **identifier** and **article-no.**

Assembly	Identifier	Article-no.	Position	Figure no.
Drive PX-MFC 90 D	rear guard plate	9753847	2	17
	guard plate for gate	9753849	3	19
	felt sealing	9754157	3	17
	o-ring for gate	9341828	2	19
	o-ring for rotary slide	9320067	3	18
	rotary slide	9753974	2	18
	rubber foot	9323028	-	2
Hammer-grinding attachment	hammer-grinding stator	9753848	-	3
	center	9754186	1	15
	sealing center	9753834	-	3
	set of 3 hammers with pins	9754185	2	15
Blade-grinding attachment	blade rotor	9753898	3	16
	blade stator	9753901	4	
	countersink screw M5x16	9940516	5	
	countersink screw M4x8	9900048	6	
	stator blade	9753900	2	
	rotor blade	9753899	1	



6 TROUBLE SHOOTING

PROBLEM	CAUSE	REMEDY
unusual noise	Bearing at drive motor damaged	Change ball bearings, find and replace defective parts
Heating up	Insufficient cooling Damaged bearing Overload	Check ventilation slots Change ball bearings Check application
Vibrations	Twisted shaft Worn bearings	Replace shaft Replace bearings. Find and replace defective parts
Drive not running Display shows O-I	Drive overloaded Unit jammed Motor or wiring defective	Check drive for overload and jamming Check wiring. Reset and restart.
Drive running out Display shows O-Uolt	Too high voltage in frequency converter Braking time too short	Check power supply voltage Set potentiometer back more slowly
Drive not running Display shows U-Uolt	Too low voltage in frequency converter	Check power supply voltage
Drive not running anymore Display shows I.t-trP	Drive overloaded 150% current for more than a minute	Check load Reset and restart.
Drive not running anymore Display shows E-triP	Motor overheated Wiring of control unit to drive defective	Check ventilation slots Check wiring
Product leaking from gap between chamber and gate.	O-ring in gate defective	Replace O-ring.

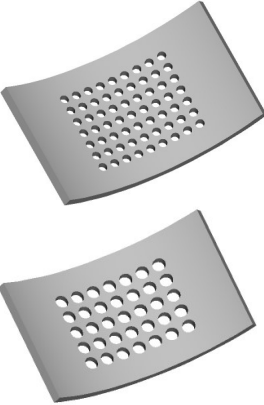

7 ACCESSORIES

	Stodger	Order-No.	Dimensions	Material
	Is used for the active feeding of stringy materials via the hopper, which cannot be fed by its own weight.	35080001	300 x 26 x 23 mm	POM black
	Sieves	Order-No.	Diameter-Ø	Material
	Insert sieves can be ordered with hole diameters from 0.2 to 6.0 (*) mm and are made from stainless steel. (*) Special mesh sizes are available on request.	9609088 9609089 9609090 9609092 9609093 9609094 9609091 9609105 9609106 9609107	0.2 mm 0.5 mm 0.8 mm 1.0 mm 1.5 mm 2.0 mm 3.0 mm 4.0 mm 5.0 mm 6.0 mm	steel 1.4034



8 WARRANTY

KINEMATICA AG guarantees the flawless function of this machine manufactured by it for a period of **12 months** with reference to material and manufacturing defects.

KINEMATICA AG assures free repair of the machine or free replacement of delivered defective parts, respectively, when close examination proves that it is a matter of a material and/or manufacturing defect,

Exempt from the warranty are parts, which are subject to normal wear, or if someone other than KINEMATICA AG employees or their designated representatives have made changes to the equipment or the damage can be traced back to non-observance of the operating instructions, imprudence, accident, wrong utilisation or incorrect electrical voltage.

KINEMATICA AG reserves the right of technical changes to the machines, without implementing these retroactively in machines delivered earlier.

In case of technical problems, need of spare parts or for advice, please contact our regional designated agent, your preferred special dealer or us directly.

KINEMATICA AG

Luzernerstr. 147a
CH-6014 Littau-Luzern
Schweiz

Tel. +41-41-259 65 65
Fax +41-41-259 65 75
eMail info@kinematica.ch



Appendix A. Dimensional drawings

Drive PX-MFC 90 D

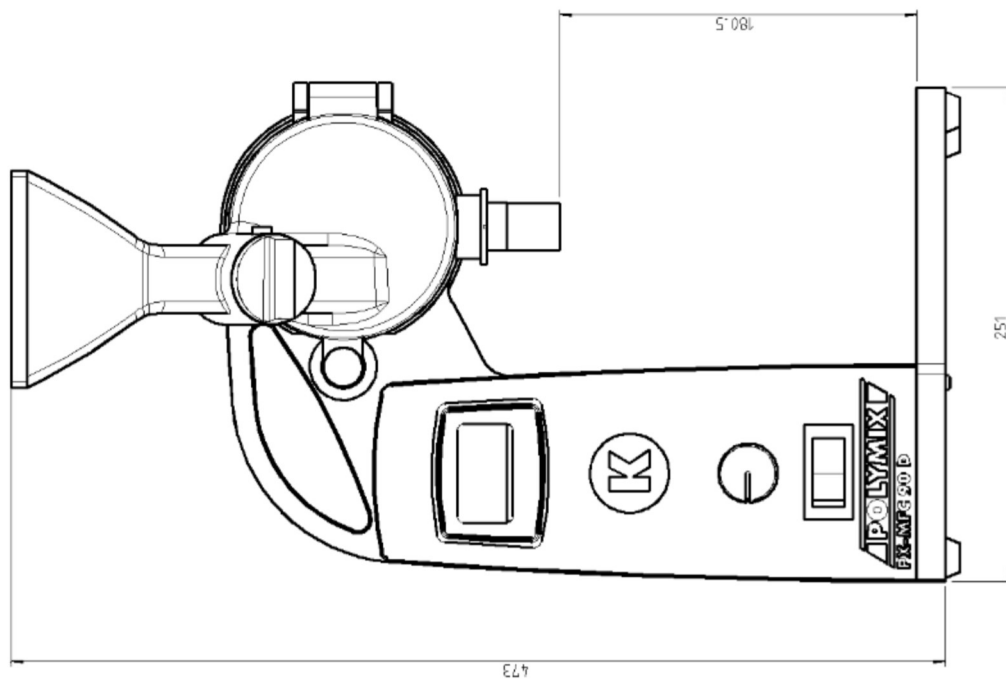
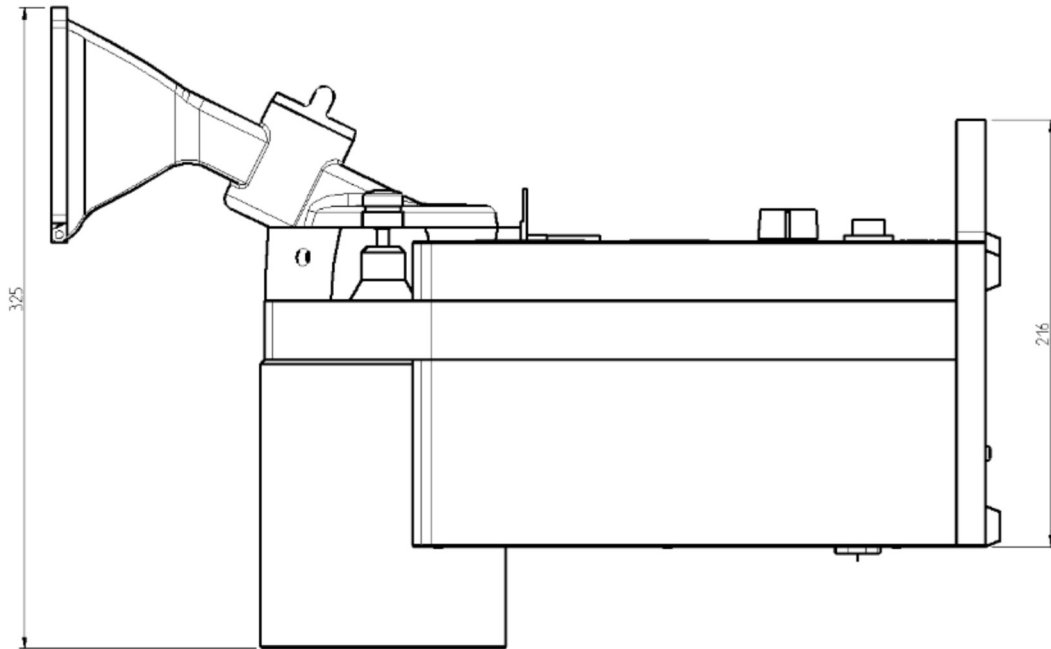



Appendix B. Parts lists

Assembly	Main Identification	Order-No.	Production-No.	Products Identification
Mill with hammer-grinding attachment	POLYMIX® PX-MFC 90 D 230V / CH / H	35010020	9158043	Drive 230V with hammer-grinding attachment
			9835419	Power cable CH
			9609114	Wooden rack
			9851003	Tubes
			9754504	Tools
	POLYMIX® PX-MFC 90 D 230V / EU / H	35010021	9158043	Drive 230V with hammer-grinding attachment
			9835418	Power cable EU
			9609114	Wooden rack
			9851003	Tubes
			9754504	Tools
	POLYMIX® PX-MFC 90 D 230V / GB / H	35010022	9158043	Drive 230V with hammer-grinding attachment
			9835426	Power cable GB
			9609114	Wooden rack
			9851003	Tubes
			9754504	Tools
	POLYMIX® PX-MFC 90 D, 100..120V / H	35010023	9158044	Drive 100..120V with hammer-grinding attachment
9835416			Power cable US/JP	
9609114			Wooden rack	
9851003			Tubes	
9754504			Tools	



Parts lists continued

Assembly	Main Identification	Order-No.	Production-No.	Products Identification
Mill with blade-grinding attachment	POLYMIX® PX-MFC 90 D 230V / CH / B	35010030	9158067	Drive 230V with blade-grinding attachment
			9835419	Power cable CH
			9609114	Wooden rack
			9851003	Tubes
			9754504	Tools
			9754548	Inboard extractor
	POLYMIX® PX-MFC 90 D 230V / EU / B	35010031	9158067	Drive 230V with blade-grinding attachment
			9835419	Power cable EU
			9609114	Wooden rack
			9851003	Tubes
			9754504	Tools
			9754548	Inboard extractor
	POLYMIX® PX-MFC 90 D 230V / GB / B	35010032	9158067	Drive 230V with blade-grinding attachment
			9835419	Power cable GB
			9609114	Wooden rack
			9851003	Tubes
			9754504	Tools
			9754548	Inboard extractor
	POLYMIX® PX-MFC 90 D, 100..120V / B	35010033	9158068	Drive 100..120V with blade-grinding attachment
			9835419	Power cable US/JP
9609114			Wooden rack	
9851003			Tubes	
9754504			Tools	
9754548			Inboard extractor	
Grinding attachments	hammer-grinding attachment	35031001	9753834	Sealing centre
			9753848	Hammer-grinding stator
			9341587	Hammer-grinding rotor
			9951135	Hexagon screw M4x16 A2
	blade-grinding attachment	35031002	9115343	Blade-grinding rotor
			9115344	Blade-grinding stator
			9951135	Hexagon screw M4x16 A2
			9753902	Sealing centre
			9754548	Inboard extractor
			9300112	Wrench 3 mm
9300117	Wrench 2.5 mm			



Belgique / België	tél 056 260 260	fax 056 260 270	be.fisher@thermofisher.com	www.be.fishersci.com
España	tfno 91 380 67 10	fax 91 380 85 02	es.fisher@thermofisher.com	www.es.fishersci.com
France	tél 03 88 67 53 20	fax 03 88 67 11 68	fr.commande@thermofisher.com	www.fr.fishersci.com
Italia	tel 02 953 28 258	fax 02 953 27 374	it.fisher@thermofisher.com	www.it.fishersci.com
Netherlands	tel 020 487 70 00	fax 020 487 70 70	nl.info@thermofisher.com	www.nl.fishersci.com
Portugal	tel 21 425 33 50	fax 21 425 33 51	pt.fisher@thermofisher.com	www.pt.fishersci.com
Suisse / Switzerland	tél 056 618 41 11	fax 056 618 41 41	info.ch@thermofisher.com	www.ch.fishersci.com