

Model KBF-S 720 | Constant climate chambers with large temperature / humidity range

The new Solid.Line KBF-S climate chamber is a custom-made solution for long-term testing and accelerated stability testing for pharmaceutical products in accordance with the ICH Q1A guideline. The corrosion-free and condensation-free interior also ensures exceptionally stable temperature and moisture levels, even when fully loaded.

BENEFITS

- Homogeneous climate conditions thanks to APT.line™ preheating chamber
- Standard-compliant testing according to ICH Q1A
- Precise temperature and humidity control



Model KBF-S 720

MAIN FEATURES

- Temperature range: 0 °C to 70 °C
- Humidity range: 20% to 80% RH
- APT.line™ preheating chamber technology
- Humidity regulation with capacitive humidity sensor and steam humidification
- LCD to display temperature and humidity along with additional information and alarms
- Internal data logger, measured values can be read out in open format via USB
- Unit self-test for comprehensive status analysis
- Inner chamber made completely of stainless steel
- 2 stainless steel racks, incl. shelf supports
- Access port with silicone plug, 30 mm, left
- Robust twin casters with brakes, from 240 L
- Class 3.1 independent temperature safety device (DIN 12880) with visual and audible temperature alarm
- Computer interface: Ethernet
- Independent water supply via tank

ORDERING INFORMATION

Interior volume [L]	Voltage	Option model	Version	Art.-No.
Model KBF-S 720				
700	200...230 V 1~ ph 50/60 Hz	Standard	KBFS720-230V	9020-0368
	200...240 V 1~ ph 50/60 Hz	Standard	KBFS720UL-240V	9020-0369

TECHNICAL DATA

Description	KBFS720-230V ¹	KBFS720UL-240V ¹
Article Number	9020-0368	9020-0369
Performance Data Temperature		
Temperature range [°C]	0...70	0...70
Temperature variation at 40 °C [± K]	0.3	0.3
Temperature fluctuation [± K]	0.1	0.1
Max. heat compensation at 40 °C [W]	550	550
Performance Data Climate		
Temperature range [°C]	10...70	10...70
Temperature variation at 25 °C and 60 % RH [± K]	0.3	0.3
Temperature variation at 40 °C and 75 % RH [± K]	0.3	0.3
Temperature fluctuation at 25 °C and 60 % RH [± K]	0.1	0.1
Temperature fluctuation at 40 °C and 75 % RH [± K]	0.1	0.1
Humidity range [% RH]	20...80	20...80
Humidity fluctuation at 25 °C and 60 % RH	1,5 % RH	1,5 % RH
Humidity recovery time after 30 s door open at 25 °C and 60 % RH [min]	16	16
Humidity recovery time after 30 s door open at 40 °C and 75 % RH [min]	17	17
Electrical data		
Rated Voltage [V]	200...230	200...240
Power frequency [Hz]	50/60	50/60
Nominal power [kW]	2.0	2.0
Unit fuse [A]	16	16
Phase (Nominal voltage)	1~	1~
Outer dimensions		
Width net [mm]	1250	1250
Height net [mm]	1925	1925
Depth net [mm]	890	890
Wall clearance back [mm]	100	100
Doors		
Unit doors	2	2
Internal Dimensions		
Width [mm]	973	973
Height [mm]	1250	1250
Depth [mm]	576	576
Measures		
Interior volume [L]	700	700
Net weight of the unit (empty) [kg]	284	284
permitted load [kg]	150	150
Load per rack [kg]	45	45
Environment-specific data		
Energy consumption at 40 °C and 75 % RH [Wh/h]	500	500
Sound-pressure level [dB(A)]	53	53
Fixtures		
Number of shelves (std./max.)	2/15	2/15

¹ All technical data is specified for unloaded units with standard equipment at an ambient temperature of +22 °C ±3 °C and a power supply voltage fluctuation of ±10 %. The temperature data is determined in accordance to BINDER factory standard following DIN 12880, observing the recommended wall clearances of 10 % of the height, width, and depth of the inner chamber. Technical data refers to 100 % fan speed. All indications are average values, typical for units produced in series. We reserve the right to change technical specifications at any time.

DIMENSIONS incl. fittings and connections [mm]

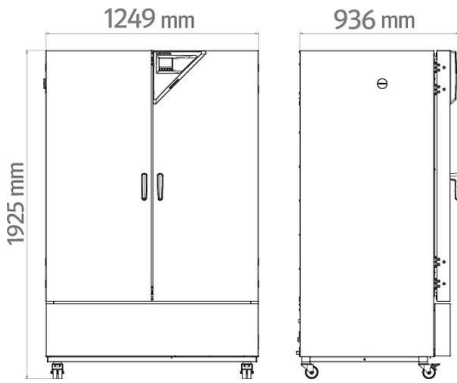

CHARTS

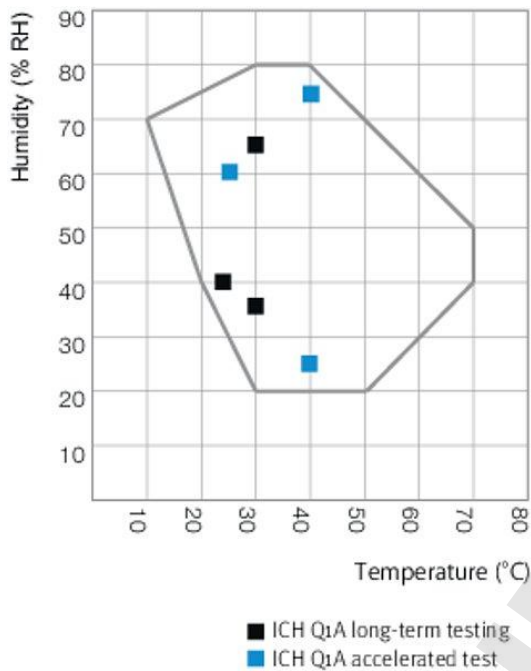

Climate chart

OPTIONS AND ACCESSORIES

Designation	Description	*	Art.-No.
	left		
	30 mm	01	8012-1442
	50 mm	01	8012-1472
	100 mm	01	8012-0515
	right		
Access port with silicone plug	30 mm	01	8012-1436
	50 mm	01	8012-1466
	100 mm	01	8012-0514
	top		
	30 mm	01	8012-1448
	50 mm	01	8012-1454
	100 mm	01	8012-1460
APT-COM™ 4 BASIC-Edition	for simple logging and documentation requirements with up to 5 networked units. version 4, BASIC edition	19	9053-0039

* Notes › See last page

Designation	Description	*	Art.-No.
APT-COM™ 4 GLP-Edition	for working under GLP-compliant conditions. Measured values are documented in a tamper-proof way in line with the requirements of FDA Regulation 21 CFR 11. version 4, GLP edition	19	9053-0042
APT-COM™ 4 PROFESSIONAL-Edition	convenient unit and user management built on the BASIC edition. Suitable for networking up to 100 units. version 4, PROFESSIONAL edition	19	9053-0040
BINDER PURE AQUA SERVICE	system for preparation or complete desalination of tap water, containing single-use cartridge, hoses and measuring device	-	8012-0759
BINDER PURE AQUA SERVICE, accessories	Single-use, replacement cartridge for BINDER PURE AQUA System	-	6011-0165
Calibration certificate, expanded	for temperature and humidity; for extending the measurement in center of chamber to include another test value	-	8012-0155
Calibration certificate, temperature	temperature measurement incl. certificate and 27 measuring points at specified temperature	-	8012-0923
	temperature measurement incl. certificate, 15- 18 measuring points at specified temperature	-	8012-0920
	temperature measurement incl. certificate, 9 measuring points at specified temperature	-	8012-0917
Calibration certificate, temperature and humidity	Measurement in center of chamber at 25 °C / 60% RH or at specified test values	-	8012-0154
	temperature (according to DIN12880) and humidity measurement incl. certificate, 27 temperature measuring points and 1 humidity measuring point, at 25 °C / 60 % RH or at specified values	-	8012-0924
Convenient water supply	Flexible positioning of the water container with magnetic holder, hose adapter for water container with practical quick coupling, and water stop function		
	External, with magnetic holder	-	8012-1847
Data Logger Kit	T 220: For continuous temperature logging from -90 °C to 220 °C. The kit includes 1 data logger, Pt 100 sensor with 2 m extension cable and 1 magnetic fixture for mounting to the BINDER unit	19	8012-0715
	TH 70/70: For continuous temperature and humidity logging from -40 °C to 70 °C / 0% to 100% RH and additional logging of ambient conditions. Kit includes 1 data logger, 2 attachable combined humidity/temperature sensors, 2 m extension cable and 1 fixture for mounting to the BINDER unit	19	8012-0717
	TH 70: For continuous temperature and humidity logging from -40 °C to 70 °C; 0% to 100% RH. Kit includes 1 data logger, Pt 100 sensor with 2 m extension cable, and 1 magnetic fixture for mounting to the BINDER unit	19	8012-0716
Data Logger Software	LOG ANALYZE software kit, configuration and evaluation software for all BINDER Data Logger Kits (incl. USB data cable)	19	8012-0821
Interior socket	Waterproof, switched flush-mounting box (CA3GD) for nominal voltage in unit interior, with cover and corresponding plug (nominal voltage; max. 500 W; max. 90 °C; protection class IP67)	07	8012-1043
LED light bars	Basic set consisting of 2 pieces, attachment material, control unit for max. 4 light strips, 100-240 V, 50/60 Hz		
	Basic set 300, length 30 cm	-	8012-1107
	Basic set 500, length 50 cm	-	8012-1108
	Basic set 900, length 90 cm	-	8012-1109
	Expansion set consisting of 2 pieces, attachment material: clips. For expanding the basic set of light bars		
	Expansion set 300, length 30 cm	-	8012-1716
	Expansion set 500, length 50 cm	-	8012-1717
Expansion set 900, length 90 cm	-	8012-1718	
pH-neutral detergent	concentrated, for gentle remove of residual contaminants; 1 kg	-	1002-0016
Qualification folder IQ/OQ	supporting documents for validation performed by customer, consisting of: IQ/OQ checklists, unit schematics, QM certificate in accordance with ISO 9001	15, 18, 20	8012-1873
Qualification folder IQ/OQ/PQ	supporting documents for validation performed by customer, in accordance with customer's requirement, extension of Qualification folder IQ/OQ by chapter PQ	15, 18	8012-1874
Rack	stainless steel	-	6004-0106
Rack accessories	fasteners (1 set of 4) for additional security of racks	-	8012-0620
Rack, reinforced	stainless steel, with fasteners (1 set of 4)	-	8012-0674
Shelf, perforated	Stainless steel	-	8009-0486
Shelf, reinforced	positioned at bottom level, max. load 67 kg, with additional attachment for operation of shaking device, stirring device or roller bottle system	-	8012-1489

* Notes › See last page

SERVICES

Designation	Description	*	Art.-No.
Installation services			
Installation	and set up of unit at operating location, connect to existing connections	13, 18	DL10-0300
Instruction	unit function instructions for operation and programming of the controller	18	DL10-0700
Preventive maintenance			
Preventive maintenance	Executive of equipment inspection according to maintenance plan	14, 18	DL20-0400
Calibration services			
Calibration temperature and humidity	including certificate, one measuring point in center of chamber at 25 °C / 60 % RH or at specified values	14, 16, 17, 18	DL30-0301
Temperature and humidity measurement according to DIN12880	including certificate (27 temperature measuring points and one humidity measuring point, at 25 °C / 60 % RH or at specified values)	14, 16, 17, 18	DL30-0427
Temperature measurement 18 temperature measuring points and 1 humidity measuring point	including certificate, 18 temperature measuring points and 1 humidity measuring point in center of chamber, at 25 °C / 60 % RH or at specified values	14, 16, 17, 18	DL30-0318
Temperature measurement 27 temperature measuring points and 1 humidity measuring point	including certificate, 27 temperature measuring points and 1 humidity measuring point in center of chamber, at 25 °C / 60 % RH or at specified values	14, 16, 17, 18	DL30-0327
Temperature measurement 9 temperature measuring points and 1 humidity measuring point	including certificate, 9 temperature measuring points and 1 humidity measuring point in center of chamber, at 25 °C / 60 % RH or at specified values	14, 16, 17, 18	DL30-0309
Validation services			
Execution of IQ/OQ	in accordance with qualification folder	15, 18, 20	DL42-0300
Execution of IQ/OQ/PQ	in accordance with customer's requirement, price: on request	15, 18	DL44-0500

* Notes › See last page

NOTES

- 01 Condensation may occur in the area around the access port. Access ports may be placed in custom locations for an additional charge.
- 02 UL mark is not granted when this option is used.
- 03 Heat resistant only to max. 200 °C.
- 04 Only available on units rated for 230 V.
- 06 Heating-up time may increase as a result of the lower heat conductivity.
- 07 The additional heat input may affect the temperature behavior.
- 09 Not in conjunction with the optional access port, door with window and interior lighting.
- 10 Not available on 23-liter units.
- 11 Not available on 23- or 53-liter units.
- 12 Only available on units rated for 230 V or 400 V.
- 13 Installation and connections take place at unit location; transport within the company only upon consultation.
- 14 We recommend a BINDER service contract to cover unit inspections, calibrations and validations.
- 15 OQ according to Yellow Paper = completed factory validation documentation of all OQ checklists.
- 16 Sensor calibration is performed in an accredited calibration laboratory.
- 17 Calibration is performed according to the BINDER factory standard.
- 18 Quoted prices do not include travel costs. Please refer to the chapter on BINDER Service for travel costs for your region. Quoted prices for services performed in Switzerland do not include a country-specific added fee (available on request).
- 19 For additional accessories, refer to the Process documentation chapter.
- 20 When ordering IQ/OQ qualification folders and associated IQ/OQ execution on one order, we offer a 15 % discount for the item of the IQ/OQ folder.
When ordering IQ/OQ/PQ qualification folders and associated IQ/OQ/PQ execution on one order, we offer a 15 % discount for the item of the IQ/OQ/PQ folder.

BINDER GmbH
Tuttlingen, Germany
TEL +49 7462 2005 0
FAX +49 7462 2005 100
info@binder-world.com
www.binder-world.com

BINDER Asia Pacific (Hong Kong) Ltd.
Kowloon, Hong Kong, P.R. China
TEL +852 39070500
FAX +852 39070507
asia@binder-world.com
www.binder-world.com

Representative Office for CIS
Moscow, Russia
TEL +7 495 988 15 16
FAX +7 495 988 15 17
russia@binder-world.com
www.binder-world.ru

BINDER Environmental Testing
Equipment (Shanghai) Co., Ltd.
Shanghai, P.R. China
TEL +86 21 685 808 25
FAX +86 21 685 808 29
china@binder-world.com
www.binder-world.com

BINDER Inc.
Bohemia, NY, USA
TEL +1 631 224 4340
FAX +1 631 224 4354
usa@binder-world.com
www.binder-world.us