

Thank you for purchasing this Esco Biological Safety Cabinet. Please read this manual thoroughly to familiarize yourself with the many unique features and exciting innovations we have built into your new equipment. Esco provides many other resources at our website, www.escoglobal.com, to complement this manual and help you enjoy many years of productive and safe use of your Esco products.



User Manual

For Technical Service, contact North America

Esco Technologies, Inc.
903 Sheehy Drive, Suite F, Horsham, PA 19044, USA
Toll-Free USA and Canada 1-877-479-3726
Tel 215-441-9661 • Fax 484-698-7757
eti.sales@escoglobal.com • www.escolifesciences.us

Rest of the World

Esco Micro Pte. Ltd.
21 Changi South Street 1 • Singapore 486777
Tel +65 6542 0833 • Fax +65 6542 6920
www.escoglobal.com • mail@escoglobal.com

Airstream® Class II Biological Safety Cabinet

Copyright Information

© Copyright 2013 Esco Micro Pte Ltd. All rights reserved.

The information contained in this manual and the accompanying product is copyrighted and all rights are reserved by Esco.

Esco reserves the right to make periodic minor design changes without obligation to notify any person or entity of such change.

Sentinel® and Airstream® are registered trademarks of Esco.

“Material in this manual is provided for informational purposes only. The contents and the product described in this manual (including any appendix, addendum, attachment or inclusion), are subject to change without notice. Esco makes no representations or warranties as to the accuracy of the information contained in this manual. In no event shall Esco be held liable for any damages, direct or consequential, arising out of or related to the use of this manual.”

Table of Contents

INTRODUCTION

i	Table of Contents
iii	Warranty Terms and Conditions
v	Introduction
v	1. Products Covered
v	2. Safety Warning
v	3. Limitation of Liability
vi	4. European Union Directives on WEEE and RoHS
vii	Declaration of Conformity

1 Chapter 1 - Product Information

1	1.1 Quick View
---	----------------

2 Chapter 2 - Sentinel Control System

2	2.1 Sentinel Control System
3	2.2 Menu Options
4	2.2.1 Settings
5	2.2.2 Setting Mode
5	2.2.3 Field Calibration
6	2.2.4 Admin Settings
8	2.3 Stopwatch and Experiment Timer (Only for non-motorized sash BSC)
8	2.4 Alarms and Warnings
9	2.5 Diagnostic Mode
10	2.5 Standby Mode (Half Speed)

11 Chapter 3 - Basic Cabinet Operation

11	3.1 Sash Window Operation
11	3.1.1 Sash Window State
11	3.1.2 Operating Motorized Sash Window (Only for BSC with motorized sash window)
12	3.1.3 Using Sash Window
12	3.2 Starting and Shutting Down the BSC
12	3.2.1 Turning on the BSC
12	3.2.2 Turning off the BSC
12	3.3 Working in the BSC
13	3.4 Working Ergonomics
14	3.5 UV Lamps (If Present)
14	3.6 Decontamination and Disinfecting Agents
15	3.7 Gaseous Decontamination
15	3.8 Further Information

16 Chapter 4 - Maintenance

16	4.1 Scheduled Maintenance
18	4.2 Maintenance/Service Log

20 Error! Reference source not found. Error! Reference source not found.

20	8.1 AC2-_E_ Engineering Drawing
21	8.2 AC2-_S_ Engineering Drawing
22	8.3 AC2-_E_ and AC2-_S_ General Specifications
23	8.4 AC2-_D_ Engineering Drawing
24	8.5 AC2-_G_ Engineering Drawing
25	8.6 AC2-_D_ and AC2-_G_ General Specifications
26	8.7 AC2-2N7 Engineering Drawing
28	8.8 AC2-2N7 General Specifications

Warranty Terms and Conditions

Esco products come with a limited warranty. The warranty period will vary depending on the product purchased, beginning on the date of shipment from any Esco international warehousing location. To determine which warranty applies to your product, refer to the appendix below.

Esco's limited warranty covers defects in materials and workmanship. Esco's liability under this limited warranty shall be, at our option, to repair or replace any defective parts of the equipment, provided that these parts, if proven to the satisfaction of Esco, were defective at the time of being sold and that all defective parts shall be returned, properly identified with a Return Authorization.

This limited warranty covers parts only, and not transportation/insurance charges.

This limited warranty does not cover:

- Freight or installation (inside delivery handling) damage. If your product was damaged in transit, you must file a claim directly with the freight carrier.
- Products with missing or defaced serial numbers.
- Products for which Esco has not received payment.
- Problems that result from:
 - External causes such as accident, abuse, misuse, problems with electrical power, improper operating environmental conditions.
 - Servicing not authorized by Esco.
 - Usage that is not in accordance with product instructions.
 - Failure to follow the product instructions.
 - Failure to perform preventive maintenance.
 - Using accessories, parts, or components not supplied by Esco.
 - Damage by fire, floods, or acts of God.
 - Customer modifications to the product.
- Consumables such as filters (HEPA, ULPA, carbon, pre-filters) and fluorescent / UV bulbs.

Factory installed, customer specified equipment or accessories are warranted only to the extent guaranteed by the original manufacturer. The customer agrees that in relation to these products purchased through Esco, our limited warranty shall not apply and the original manufacturer's warranty shall be the sole warranty in respect of these products. The customer shall utilize that warranty for the support of such products and in any event not look to Esco for such warranty support.

Esco encourages all users to register their equipment online at www.escoglobal.com/warranty_registrations.php or complete the warranty registration form included with each product.

ALL EXPRESS AND IMPLIED WARRANTIES FOR THE PRODUCT, INCLUDING BUT NOT LIMITED TO ANY IMPLIED WARRANTIES AND CONDITIONS OF MERCHANTABILITY AND FITNESS FOR A PARTICULAR PURPOSE ARE LIMITED IN TIME TO THE TERM OF THIS LIMITED WARRANTY. NO WARRANTIES, WHETHER EXPRESS OR IMPLIED, WILL APPLY AFTER THE LIMITED WARRANTY PERIOD HAS EXPIRED. ESCO DOES NOT ACCEPT LIABILITY BEYOND THE REMEDIES PROVIDED FOR IN THIS LIMITED WARRANTY OR FOR SPECIAL, INDIRECT, CONSEQUENTIAL OR INCIDENTAL DAMAGES, INCLUDING, WITHOUT LIMITATION, ANY LIABILITY FOR THIRD-PARTY CLAIMS AGAINST YOU FOR DAMAGES, FOR PRODUCTS NOT BEING AVAILABLE FOR USE, OR FOR LOST WORK. ESCO'S LIABILITY WILL BE NO

MORE THAN THE AMOUNT YOU PAID FOR THE PRODUCT THAT IS THE SUBJECT OF A CLAIM. THIS IS THE MAXIMUM AMOUNT FOR WHICH ESCO IS RESPONSIBLE.

These Terms and Conditions shall be governed by and construed in accordance with the laws of Singapore and shall be subject to the exclusive jurisdiction of the courts of Singapore.

Technical Support, Warranty Service Contacts

USA: 1-888-479-ESCO

Singapore: +65 6542 0833

Global Email Helpdesk: support@escoglobal.com

Visit <http://escoglobal.com> to talk to a Live Support Representative

Distributors are encouraged to visit the Distributor Intranet for self-help materials.

Product Appendix, Warranty Listings

<i>Biological Safety Cabinets, Laminar Flow Cabinets, HEPA-Filtered Cabinets (except Streamline brand)</i>	3 years limited
<i>Laboratory Fume Hoods</i>	2 years limited
<i>Ductless Fume Hoods</i>	2 years limited
<i>Cleanroom Equipment</i>	1 year limited
<i>Laboratory Ovens and Incubators</i>	1 year limited
<i>CO₂ Incubators</i>	2 years limited
<i>Containment/Pharma Products</i>	2 years limited
<i>Ultra-low Temperature Freezer</i>	5 years limited 5 years on compressor
<i>Benchtop Incubator</i>	2 years limited
<i>Thermal Cyclers</i>	3 years limited for MiniPro, MaxPro, Provocell 2 years limited for Spectrum 2 years on blocks and Peltier units 2 years on all electronic components 3 years on the housing and fans

Policy updated on 1st January 2012

Applies to all units ordered on and after 1st January 2012

Introduction

1. Products Covered

Esco Class II Biological Safety Cabinet						
Model	Electrical Rating	0.6 meters 2 feet	0.9 meters 3 feet	1.2 meters 4 feet	1.5 meters 5 feet	1.8 meters 6 feet
Airstream	220-240 VAC, 50/60Hz, 1Φ	AC2-2E8 AC2-2S8	AC2-3E8 AC2-3E8-M AC2-3S8 AC2-3S8-M	AC2-4E8 AC2-4E8-M AC2-4S8 AC2-4S8-M	AC2-5E8 AC2-5E8-M AC2-5S8 AC2-5S8-M	AC2-6E8 AC2-6E8-M AC2-6S8 AC2-6S8-M
	110-130 VAC, 50/60Hz, 1Φ	AC2-2E9 AC2-2S9	AC2-3E9 AC2-3E9-M AC2-3S9 AC2-3S9-M	AC2-4E9 AC2-4E9-M AC2-4S9 AC2-4S9-M	AC2-5E9 AC2-5E9-M AC2-5S9 AC2-5S9-M	AC2-6E9 AC2-6E9-M AC2-6S9 AC2-6S9-M
	90-110 VAC, 50/60Hz, 1Φ	AC2-2N7	AC2-3N7	AC2-4N7 AC2-4E7	AC2-5N7	AC2-6N7
Airstream Duo	220-240 VAC, 50/60Hz, 1Φ			AC2-4D8 AC2-4G8		AC2-6D8 AC2-6G8

2. Safety Warning

- Anyone working with, on or around this equipment should read this manual. Failure to read, understand and comply with the instructions given in this manual may result in damage to the unit, injury to operating personnel, and / or poor equipment performance.
- Any internal adjustment, modification or maintenance to this equipment must be undertaken by qualified service personnel.
- The use of any hazardous materials in this equipment must be monitored by an industrial hygienist, safety officer or some other suitably qualified individuals.
- Before you process, you should thoroughly understand the installation procedures and take note of the environmental / electrical requirements.
- In this manual, important safety related points will be marked with the symbol. 
- If the equipment is used in a manner not specified by this manual, the protection provided by this equipment may be impaired.

3. Limitation of Liability

The disposal and / or emission of substances used in connection with this equipment may be governed by various local regulations. Familiarization and compliance with any such regulations are the sole responsibility of the users. Esco's liability is limited with respect to user compliance with such regulations.

4. European Union Directive on WEEE and RoHS

The European Union has issued two directives:

- **Directive 2002/96/EC on Waste Electrical and Electronic Equipment (WEEE)**

This product is required to comply with the European Union's Waste Electrical & Electronic Equipment (WEEE) Directive 2002/96/EC. It is marked with the following symbol:

Esco sells products through distributors throughout Europe. Contact your local Esco distributor for recycling/disposal.



- **Directive 2002/95/EC on Restriction on the use of Hazardous Substances (RoHS)**

With respect to the directive on RoHS, please note that this cabinet falls under category 8 (medical devices) and category 9 (monitoring and control instruments) and is therefore exempted from requirement to comply with the provisions of this directive.

Declaration of Conformation

In accordance to EN ISO/IEC 17050-1:2010

We, Esco Micro Pte Ltd
of 21 Changi South Street 1
Singapore, 486777
Tel: +65 6542 0833
Fax: +65 6542 6920

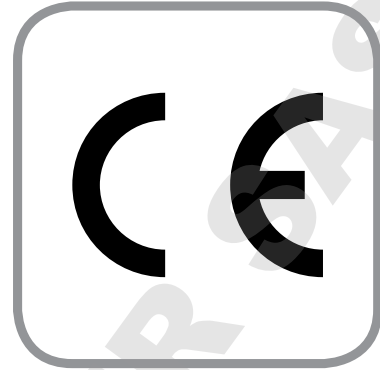

declare on our sole responsibility that the product:

Category : Class II Biological Safety Cabinet
Brand : Airstream
Model : AC2-2E8, AC2-3E8, AC2-4E8, AC2-5E8, AC2-6E8, AC2-3E8-M, AC2-4E8-M,
AC2-5E8-M, AC2-6E8-M, AC2-2S8, AC2-3S8, AC2-4S8, AC2-5S8, AC2-6S8,
AC2-3S8-M, AC2-4S8-M, AC2-5S8-M, AC2-6S8-M

in accordance with the following directives:

2006/95/EEC : The Low Voltage Directive and its amending directives
2004/108/CE : The Electromagnetic Compatibility Directive and its amending directives

has been designed to comply with the requirement of the following Harmonized Standard:

Low Voltage : EN 61010-1:2001
EMC : EN 61326-1:2006 Class B
Design/ Performance Criteria : EN 12469 (2000) Class II Biological Safety Cabinet

More information may be obtained from Esco's authorized distributors located within the European Union. A list of these parties and their contact information is available on request from Esco.

A handwritten signature in black ink, appearing to read 'XQ Lin', is written over a horizontal line. The signature is located in the lower left area of the page.

XQ Lin
Group CEO, ESCO

This Declaration of Conformity is only applicable for 230VAC 50/60Hz units

Declaration of Conformation

In accordance to EN ISO/IEC 17050-1:2010

We, Esco Micro Pte Ltd
of 21 Changi South Street 1
Singapore, 486777
Tel: +65 6542 0833
Fax: +65 6542 6920

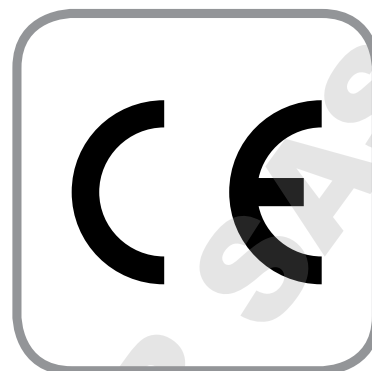

declare on our sole responsibility that the product:

Category : Class II Biological Safety Cabinet
Brand : Airstream Duo
Model : AC2-4D8, AC2-6D8, AC2-4G8, AC2-6G8

in accordance with the following directives:

2006/95/EEC : The Low Voltage Directive and its amending directives
2004/108/CE : The Electromagnetic Compatibility Directive and its amending directives

has been designed to comply with the requirement of the following Harmonized Standard:

Low Voltage : EN 61010-1:2001
EMC : EN 61326-1:2006 Class B
Design/ Performance Criteria : EN 12469 (2000) Class II Biological Safety Cabinet

More information may be obtained from Esco's authorized distributors located within the European Union. A list of these parties and their contact information is available on request from Esco.

A handwritten signature in black ink, appearing to read 'XQ Lin', is positioned above a horizontal line. The signature is located in the lower left area of the page.

XQ Lin
Group CEO, ESCO

This Declaration of Conformity is only applicable for 230VAC 50/60Hz units

DOMINIQUE DUTSCHER SAS

Chapter 1 - Product Information

1.1. Quick View AC2 3G

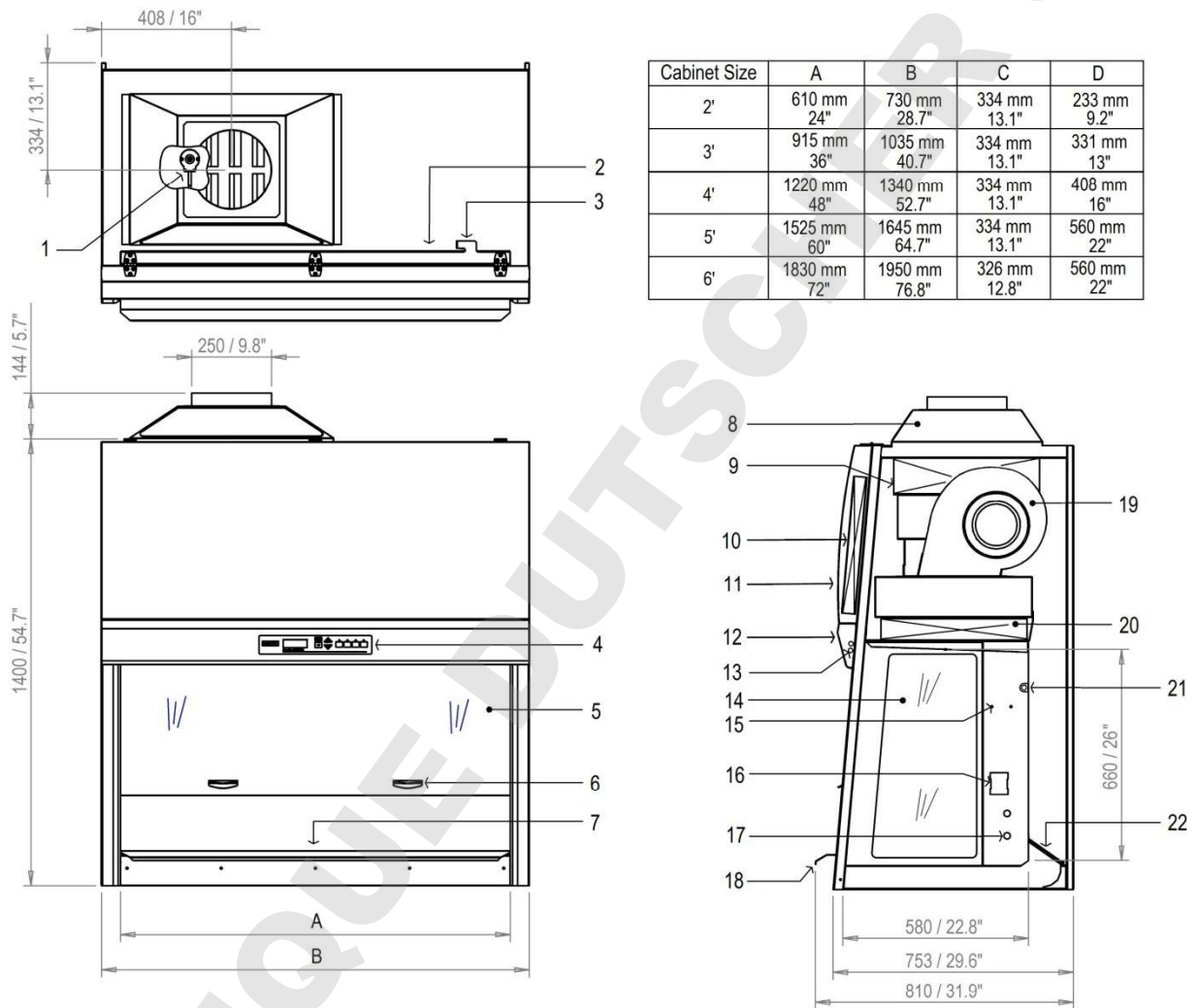

Figure 1.1. AC2 Gen 3 general parts.

- | | | |
|---------------------------------|---------------------------------------|--|
| 1. Airflow Sensor | 8. Exhaust Collar (Optional) | |
| 2. RS232 Port | 9. Exhaust ULPA Filter | |
| 3. Power Inlet | 10. Electrical Panel | |
| 4. Sentinel Gold Control System | 11. Curved Front Panel | |
| 5. Sash Window | 12. Display Panel | |
| 6. Sash Handle | 13. Fluorescent Lamps | |
| 7. Work tray | 14. Side Window | |
| | 15. IV Bar Retrofit Kit Provision | |
| | 16. Electrical Outlet Kit Provision | |
| | 17. Service Fixture Kit Provision | |
| | 18. Stainless Steel Armrest | |
| | 19. ECM Blower | |
| | 20. Downflow ULPA Filter | |
| | 21. UV Lamp | |
| | 22. Paper Catch (optional pre-filter) | |

Chapter 2 - Sentinel Control System

2.1. Sentinel Control System

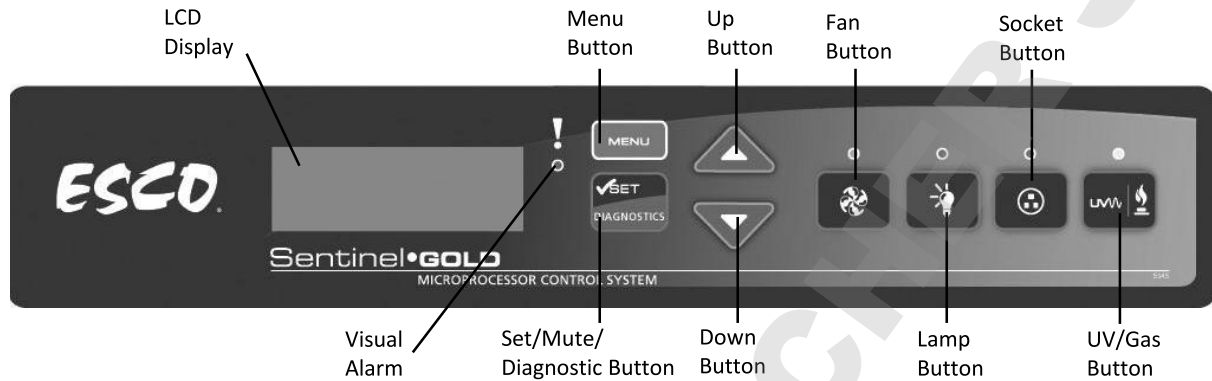

Figure 2.1. Sentinel Gold general parts.

1. Fan Button
 - Turns on and turns off the fan.
 - Activate Standby mode
2. Lamp Button
 - Turns on and turns off the fluorescent lamps.
3. Socket Button
 - Turns on and turns off the electrical socket (retrofit kit).
 - The maximum rating of all the outlets in the cabinet is 5 A. If there is overload, the fuse will blow.
4. UV/Gas Button
 - Turns on and turns off the UV lamp.
 - UV lamp can only be activated when the sash window is fully closed. Since the sash is capable of filtering UV rays, users are protected from the harmful UV radiation.
5. Up (▲) and Down (▼) Arrow Button
 - Moves the menu options upwards and downwards.
 - Increases and decreases corresponding value inside one of the menu options.
 - Moves the sash window upward and downward (for motorized sash BSC).
 - For accessing the stopwatch and experiment timer function (for non-motorized sash BSC).
6. Set or Mute or Diagnostic Button
 - To proceed to the next step, level or sequence inside the menu options.
 - Mutes the fully opened sash and airfail alarm sound (during normal and quickstart mode).
 - Enters diagnostic mode.
7. Menu Button

When you are entering menu options, the alarm will sound to indicate that the microprocessor is not monitoring the operation of the cabinet. No further warnings will be given.

- To enter and exit from the menu options.

- To go back to the previous level of the menu options.
- To access maintenance mode from error condition.

2.2. Menu Options

Please refer to the following diagram for complete reference to all menu options available.

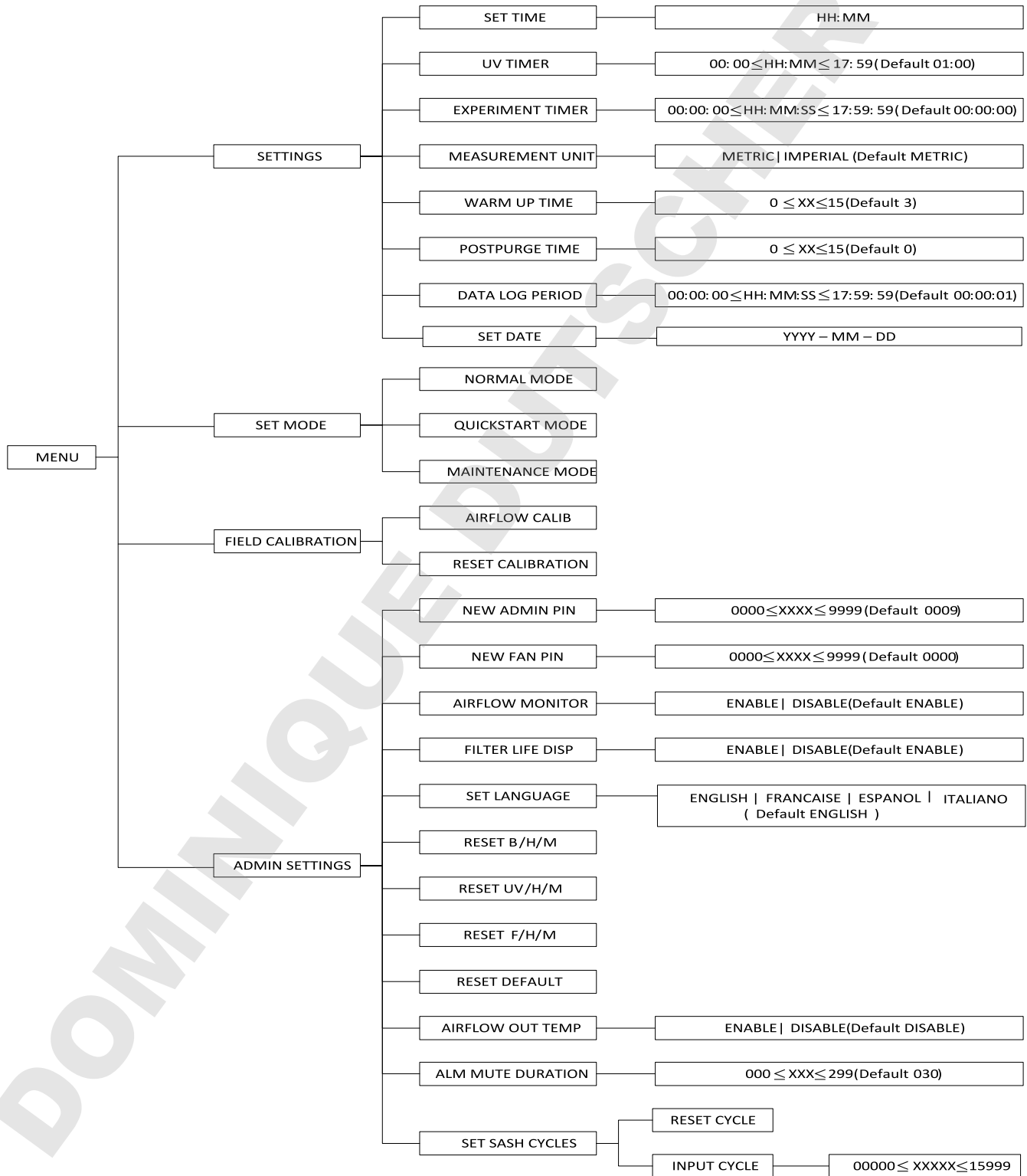

2.2.1. Settings

Users may use the settings menu function to customize the operation of the BSC to meet specific application requirements. The settings menu can be entered using either FAN PIN or ADMIN PIN.

2.2.1.1. Set Clock (Time)

Users can set the time by increasing/decreasing the hour and minute values. The correct time will be maintained even after the unit is turned off.



2.2.1.2. UV Timer (If UV present)

UV timer can be used to switch off the UV lamp automatically after a fixed period. The UV timer can be set up to 18 hours. By default, the timer is set to 60 minutes. Esco does not recommend leaving the UV lamp on for more than 60 minutes per decontamination cycle as it shortens the lifespan of the UV lamp. Unless the UV timer is activated, the lamp has to be switched off manually.

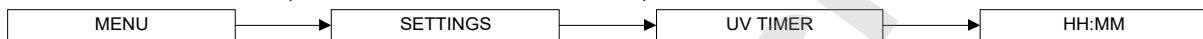

2.2.1.3. Experiment Timer (Not applicable to motorized sash BSC)

Experiment timer is a countdown timer that can be used for critical experiment. Experiment timer can be set between "00:00:00" and "17:59:59".



2.2.1.4. Measurement Unit

Using this option, the user can select the unit in which air velocity is measured and displayed. The user can choose between metric (m/s) and imperial (fpm) units.

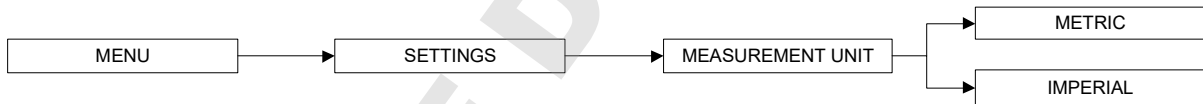

2.2.1.5. Warm Up Time

There will be a warm up period before the BSC is fully functioning upon activation of the unit. This is to ensure that the sensors, the blower, and the control system are stabilized, as well as to ensure the work zone is purged of contaminants. The default setting is 3 minutes and the user can set it between 3 to 15 minutes. *(Note: Please note that WHO Laboratory Biosafety Manual (3rd edition) advocates 5 minutes purging time prior to start of work while US Biosafety in Microbiological and Biomedical Laboratories (5th edition) advocates 4 minutes).*

During the warm up period, the user can use the FAN button to turn off the blower, LIGHT button to turn on and off the fluorescent lamp and MENU button. However, to be able to access the menu, the user needs to input ADMIN PIN and even then, some sections of the menu (WARM UP and all FIELD CALIBRATION) are still not accessible for the user. Entering the menu during this time will put the warm up period on pause.



2.2.1.6. Post Purge Time

After the user switches off the BSC blower, there will be a post-purge period, to ensure that all contaminants are purged from the work zone. The default setting is zero minute (disabled) and user can set from 0 up to 15 minutes. It is recommended that BSC is purged for a minimum of 3 minutes after the work is complete. *(Note: Please note that WHO Laboratory Biosafety Manual (3rd edition) advocates 5 minutes post purging time after work is completed while US Biosafety in Microbiological and Biomedical Laboratories (5th edition) advocates 4 minutes).*



2.2.1.7. Data Log Period

Using RS232 communication port, the BSC can send data on the condition of the BSC to a PC. Data Log Period option allows the user to control the amount of time within the BSC data sending procedure.

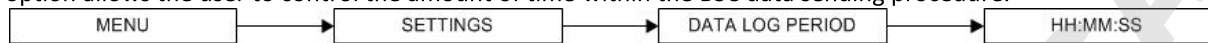

2.2.1.8. Set Date

Users can set the date by increasing/decreasing the year, month and day values. The correct date will be maintained even after the unit is turned off.

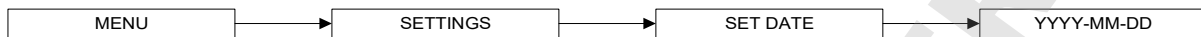

To Set Date:

1. Press MENU button to enter the menu display – if the BSC is secured by a FAN PIN, then it will ask for the PIN, otherwise go to step 3.
2. Use UP / DOWN button to enter the FAN PIN or ADMIN PIN digit by digit. Press SET button to confirm.
3. The alarm buzzer will sound.
4. Use UP / DOWN buttons to choose SETTINGS. Press SET button to confirm.
5. Use UP / DOWN buttons to choose SET DATE. Press SET button to confirm.
6. The time is set in YYYY–MM–DD format. Use UP / DOWN buttons to choose the year (YYYY). Press SET button to confirm. Do the same for the month and day.
7. The display will show DATE SET for a few second and then return to SETTINGS.
8. Press MENU button twice to return to the main display.

2.2.2. Setting Mode

The BSC has three modes and two of which, normal mode and quickstart mode, can be used in daily activity. Both of these modes can be seen and accessed when you enter the FAN PIN. The last mode, maintenance mode is for the use of qualified personnel during maintenance.

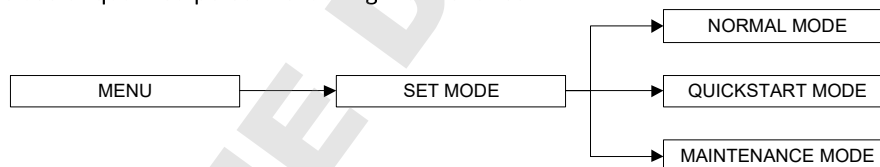

2.1.2.1. Normal Mode

The Normal mode is activated by factory default except N series. In this mode, all alarms and interlocks are enabled.

2.2.2.2. Quickstart Mode

Quickstart mode allows the user to activate the blower by simply lifting the sash from fully closed position and the light by simply lifting the sash window to the operating position. In this mode, all alarms and interlocks are enabled. This mode is activated by factory default in N series.

2.2.2.3. Maintenance Mode

Maintenance mode should only be accessed by qualified personnel during maintenance. In this mode, all alarms are disabled and all interlocks are defeated.

2.2.3. Field Calibration

The purpose of calibration is to ensure the accuracy of the airflow display and alarm (if present). This involves measuring airflow with reference instrumentation and establishing reference between airflow sensor(s) on the BSC to the standard reference. Calibration should only be carried out by qualified personnel. This section presents a brief overview of the calibration menu function. For more information, refer to test report.

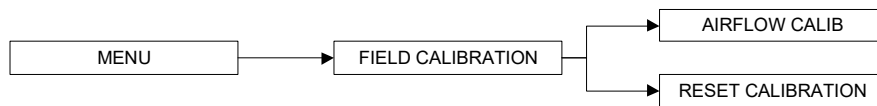

2.2.3.1. Airflow Calibration

This option allows proper calibration and operation of the airflow sensor alarm. There will be two points to be calibrated, namely inflow fail point and inflow nominal point.

2.2.3.2. Reset Calibration

This option allows the user to reset all values calibrated in the field and return it to the values obtained during factory calibration.

2.2.4. Admin Settings

The admin menu allows you to change both FAN and ADMIN PIN. The reset blower, filter and UV hour meter (if present) functions are usually used after the blower, filter or UV lamp is changed as they can easily serve as an indication to the user on when the BSC needs maintenance. The reset default function will return the options in the settings menu to their factory settings.

2.2.4.1. New ADMIN PIN (Default 0009)

ADMIN PIN restricts access to some of the more delicate menu functions, namely admin and field calibration, which should only be accessed by qualified personnel. User must enter a four-digit ADMIN PIN before accessing these menus.

ADMIN PIN can also be used to switch to maintenance mode from error condition.



2.1.4.2. New FAN PIN (Default 0000 - DISABLED)

FAN PIN restricts access to fan control and some parts of the menu, settings and set mode. User must enter the four-digit PIN before switching the fan on or off. This feature prevents unauthorized personnel from accessing critical control sections. It will also prevent unauthorized shutdown of the BSC when continuous operation is required. FAN PIN is also needed to disable the alarm when the sash is fully raised and cleaning needs to be performed.

It is recommended that the FAN PIN be issued only to personnel authorized to use the BSC. With FAN PIN, the user can access admin and set mode parts of the menu.

Setting the PIN to 0000 will disable this feature. The FAN PIN is disabled by default. When the FAN PIN is disabled, the BSC can be turned on and off without requiring PIN. However, to access the menu, the user is still required to enter the FAN PIN (0000).



2.1.4.3. Airflow Monitor

Whenever the air velocity falls below the fail point, the air fail alarm will be triggered. This option is used to enable/disable alarm. The alarm is enabled by default.

When the Airflow Monitor is disabled, the warm up period is removed but the airflow will not be displayed for the first three minutes.

If the ambient temperature is outside of 18-30°C (which is the cabinet working temperature), the Airflow Monitor is automatically disabled.

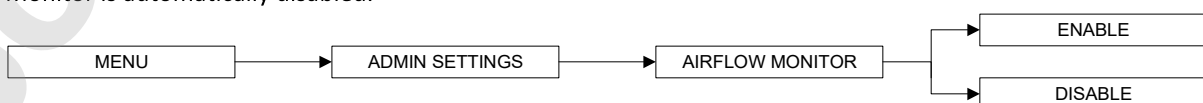

2.1.4.4. Filter Life Display

Using this option, the user can select whether the filter life is displayed or not.

Filter life is calculated based on the filter hour meter (F/H/M). The filter life display will count down according to the amount of hours left in the filter hour meter with respect to filter life expectancy of 10,000 hours. When the filter is changed, the F/H/M must be reset (*please see section 2.1.4.8 to reset the F/H/M*). Please note that the life of the filter is dependent on multiple factors which include environmental air cleanliness. A dirty / dusty environment will load the filter fast.

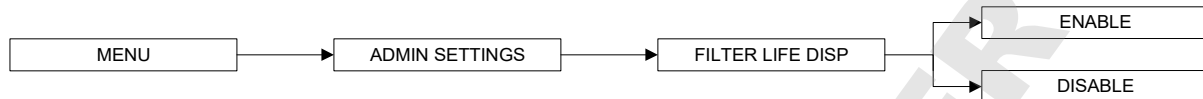

2.1.4.5. Set Language

Using this option, the user can select the language of messages displayed on the LCD.

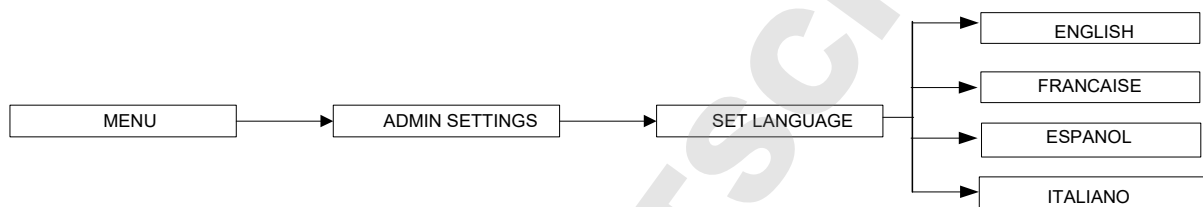

2.1.4.6. Reset B/H/M

This option is used to reset the blower hour meter. The blower hour meter indicates how long the blower has been in operation. There is no maximum value in blower hour meter. The counter value can be checked in the diagnostic mode. The value can also provide some help in setting up maintenance schedule.



2.1.4.7. Reset UV/H/M (If UV is present)

This option is used to reset the UV lamp hour meter. The UV lamp hour meter indicates how long the UV lamp has been in operation. Maximum counter is set at 2,000 hours (100%). The counter value can be checked while in the diagnostic mode. Please reset the UV lamp hour meter after each UV lamp replacement.

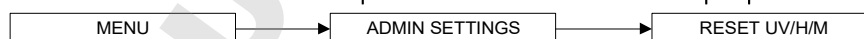

2.1.4.8. Reset F/H/M

This option is used to reset the filter hour meter. The filter hour meter indicates how long the filter has been in operation. Maximum counter is set at 10,000 hours (100%). The counter value can be checked while in the diagnostic mode. Please reset the filter hour meter after each filter replacement.

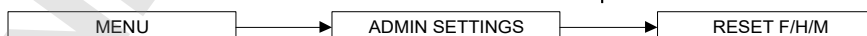

2.1.4.9. Reset Default

User can reset default settings by choosing this option. The features being reset are warm up period (3 minutes), post-purge period (0 minute), UV timer (60 minutes) if present, measurement unit (metric), airflow monitor (enabled), ADMIN PIN (0009), filter life display (disabled) and FAN PIN (0000).

Note that the calibration settings cannot be reset as it may cause the BSC to operate in an unsafe manner. The hour meters cannot be reset using this function either.

2.1.4.10. Airflow Out Temp

Using this option, the user can select whether or not to display the airflow when the ambient temperature is out of the optimum temperature range, below 18°C (65°F) or above 30°C (86°F).

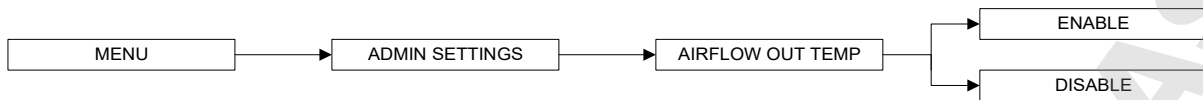

2.1.4.11. Alarm Mute Duration

To mute unsafe sash height and airflow alarm for a certain period. The mute period can be set from 0 up to 299 seconds; the default value is 30 seconds. Alarm will be activated when sash is not in the working height and when the inflow velocity is below the value prescribed by the standard the cabinet is designed or certified to.



2.1.4.12. Set Sash Cycle (Not applicable to non-motorized sash BSC)

To reset the sash cycles count to zero or to input the sash cycle count manually. The maximum value of sash cycles is 16,000 and after which the motor needs to be replaced (e.g. as part of the preventive maintenance program). The cycles will raise every sash move to up and down.

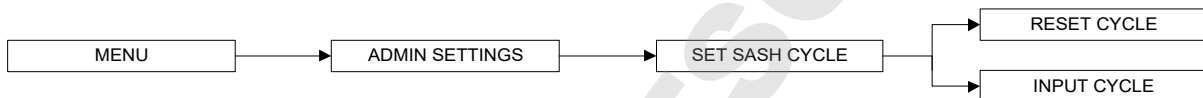

Warning message will be shown after the cycle value reaches 15,000.

- 1st warning: "Replace Sash Motor" – after sash reached 15,000 cycles.
- 2nd warning: "Stop Using Sash" - after sash reached 15,500 cycles.
- 3rd warning: "Sash Motor Locked" (sash motor cannot operate) - after sash reached 16,000 cycles.

2.1.4.13. Date Certified

This option is used to input the date the cabinet was certified. The year can be adjusted from 2000 to 2099.

2.3. Stopwatch and Experiment Timer (Only for non-motorized sash BSC)

- The stopwatch function can be started by pressing the UP button while the sash is in the safe/ready position. Pressing UP button again while the stopwatch function is activated will stop and resume the timer. Use the DOWN button to exit the stopwatch function and reset the timer. The timer in the stopwatch function is counting up and is shown using the HH:MM:SS format.
- The experiment timer can be started by pressing the DOWN button while the sash is in the safe/ready position. Pressing DOWN button while the experiment timer function is activated will stop and resume the timer. Use the UP button to exit the experiment timer function and reset the timer. The timer in the experiment timer function is counting down and is shown using the HH:MM:SS format. Operator can use the SETTINGS | EXPERIMENT TIMER menu (*refer to section 2.2.1.3*) to set the experiment timer.

2.4. Alarms and Warnings

A BSC uses alarms to indicate that the condition inside the BSC is not safe for the operator, so check the LCD display to understand the cause of these alarms. The most common alarm is the SASH ALARM, which indicates that the sash is neither at the normal operating height nor at fully closed position (UV mode) – this condition can easily be corrected by putting the sash at the appropriate operation position.

Other alarms that indicate a failure or an error in the BSC system:

- **AIRFLOW: NO!** will be displayed if there is an airflow failure.
- **SASH: ERROR POSITION** indicates a failure in the sash detection system.
- **SENSOR UNCALIBRATED** will be displayed if the airflow velocity sensor is not yet calibrated.

Note: If the message "Call Service for re-certification" is displayed, it means the BSC certification has expired. Call service or Esco's local distributor for re-certification.

2.5. Diagnostic Mode

Diagnostic mode can be accessed by pressing the SET button. The diagnostic mode allows the user to know the condition of the BSC or help the service engineer during maintenance and troubleshooting.

On Screen	Explanation
MODE	Shows which mode is active: NORMAL MODE, QUICKSTART MODE or MAINTENANCE MODE
VERSION	Shows the version of the software; eg: CP104D V 1.0
TEMPERATURE	Shows the temperature inside the cabinet.
B/H/M	Blower Hour Meter – increase by the hour.
SASH CYCLE	Shows the cycle of sash moving. Maximum cycle is 16000.
FILTER LIFE	Shows percentage of filter life (based on Filter Hour Meter) and expected filter life of 10000 hours.
AF OUT TEMP	Velocity display status when temperature out of range
UV LIFE	Shows percentage of UV lamp life (based on UV Lamp Hour Meter).
UV TIMER	Shows the UV timer value – default is 60 minutes. Maximum value is 00 minutes (infinite on).
MUTE TIMER	Shows the mute timer value – default is 30 seconds. Maximum value is 299 seconds.
ADC IFF	ADC for Fail Point Inflow – calculated using offset based on Inflow Nominal Point.
ADC IFN	ADC for Nominal Point Inflow – based on field calibration.
ADC IFA	ADC for Actual Inflow – showing real time sensor reading.
ADC IF0	ADC for factory calibrated Zero Point Inflow (no inflow).
ADC IF1	ADC for factory calibrated Fail Point Inflow.
ADC IF2	ADC for factory calibrated Nominal Point Inflow.
DFN	Nominal of Downflow – keyed in during factory or field calibration.
CONSTANT	Airflow sensor constant. This value is needed when ordering a new sensor.
CALIB TEMP	Temperature when the factory calibration was performed.
ADC TEMP	ADC value for TEMPERATURE.
M_SWITCH1	Shows the condition of magnetic switch 1 – fully open position.
M_SWITCH2	Shows the condition of magnetic switch 2 – safe position.
M_SWITCH3	Shows the condition of magnetic switch 3 – fully closed position.
TYPE	Cabinet type

2.6. Standby Mode (Half Speed)

In Standby Mode, the blower speed is greatly reduced resulting in less power consumption. This mode is typically used during the night to maintain basic level of containment where the cabinet is not used by the operator.

The mode can be accessed by pressing the FAN button when the cabinet is in operation. In half speed mode, the airflow monitor is disabled and only the FAN button is operational, while other buttons are interlocked.

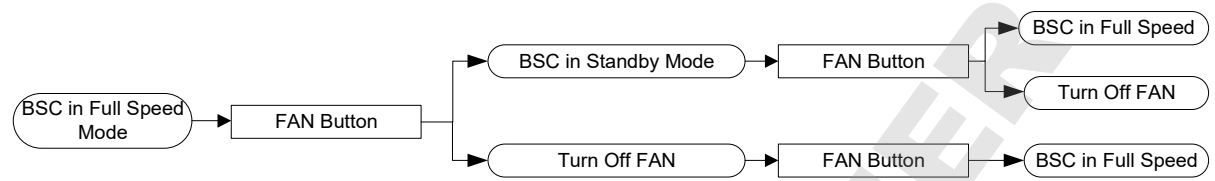

DOMINIQUE DUTSCHER

Chapter 3 - Basic Cabinet Operation

3.1. Sash Window Operation

3.1.1. Sash Window State

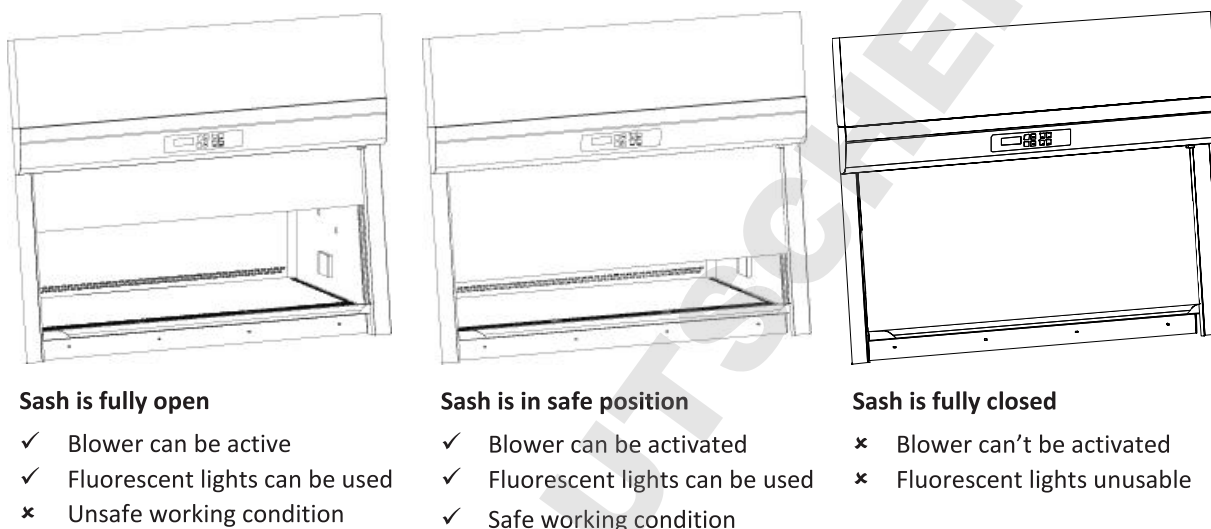

Figure 3.1. Sash window positions.

3.1.2. Operating Motorized Sash Window (Only for BSC with motorized sash window)

The motorized sash uses a “push and hold” mechanism, so if you remove your finger from the button the sash will stop immediately – this is a safety feature to control the closure and prevent anything getting trapped in the aperture as the sash descends.

Lower Sash from Fully Open Position

When the sash is fully open, pressing the down button and holding it will cause the sash to move to the Safe Height setting and stop. If the fluorescent lights are on as the sash descends, they will stay on as long as the sash stops in the Safe Position. If you release the button before the sash has reached Safe Position the lights will switch off automatically.

Lower Sash from Safe Height Position

When the sash is at safe operating height, pressing the down button and holding it will cause the sash to move down to the fully closed position and stop. If the fluorescent lights are on as the sash descends, they will switch off automatically as soon as the sash is fully closed. If you release the button before the sash has reached the fully closed position, the lights will switch off automatically.

Raise Sash from Fully Closed Position

When the sash is fully closed, pressing the up button and holding it will prompt the user to input the password to turn on the fan. If the password is correct, the fan will turn on if it was on and the sash will move up to the Safe Height setting and stop.

Raise Sash from Safe Height Position

When the sash is in safe operation position, pressing the up button and holding it will cause the sash to move up to the fully open position and stop. If the fluorescent lights are on as the sash rises, they will stay on as long as the sash is allowed to fully open. Stopping the sash midway will cause the lights to switch off automatically.

3.1.3. Using Sash Window

- The sash window should be fully closed when the cabinet is not in use. This helps to keep the work zone interior clean.
- The sash window should always be at the normal operating height at all times when the cabinet is in use. Even if the cabinet is left unattended, while the blower is on, the sash window should never be moved from the normal operating height, unless during loading or unloading of materials/apparatus into the cabinet.
- The alarm will be activated whenever the sash window is moved from the normal operating height.
- Whenever the sash window is moved to the correct height from a higher or lower position, the light will automatically be turned on as a signal to the user.
- The sash window may be opened to its maximum position for the purpose of loading/unloading of materials/apparatus into/from the cabinet. When the sash window is fully opened, the alarm sound may be muted by pressing MUTE button but the alarm will automatically sound again after 30 seconds (default is 30 seconds but can be set up to 5 minutes) to remind the user that it is not safe to work in the cabinet and the light will be turned on to facilitate cleaning.

3.2. Starting and Shutting Down the BSC

3.2.1. Turning on the BSC

1. Raise the sash to the indicated normal operational height (READY state). The lamp will turn on when this height is reached.
Note: When Quickstart mode is selected, fan will turn on as well, without pressing the fan button.
2. Turn on the fan by pressing the FAN button. Input the Fan PIN if asked (if PIN ≠ 0000). This will start the warm up procedure (default: 3 minutes). All buttons are disabled during warm up period.
3. The BSC is ready for work.

3.2.2. Turning off the BSC

1. Turn off the fan by pressing the FAN button. Input the Fan PIN if asked (if PIN ≠ 0000). This will start the post purge procedure (default: 0 minute). All buttons are disabled during post purge period.
2. Lower the sash to the fully closed position (the display will show UV MODE). The sash can be lowered immediately after turning off the fan as it will not interrupt the post purge procedure.
Note: When Quickstart mode is selected, fan will turn off without pressing the fan button.
3. Turn on the UV lamp (when present) to decontaminate the work area by pressing the UV button. Leave the UV lamp on to make sure the decontamination is done effectively. The UV lamp can only be turned on after the post purge procedure is finished.

3.3. Working in the BSC

- Allow the BSC to purge any contaminant by allowing the blower to operate for at least 3 minutes before and after using the BSC (see Section 2.2.1.5 and 2.2.1.6 of this manual for more information).
- Wear appropriate personal protective equipment (PPE) determined by your risk assessment prior to working in a BSC.
- Adjust stool height to achieve a comfortable working position.
- Perform surface decontamination on the work area (work surface, back and side walls, UV lamp, electrical outlets, service fixtures and the inner surface of the sash window) before and after using the BSC. Filter diffuser should not be wiped to prevent filter damage. Where bleach is used, a second wiping with sterile water should be carried out to remove any residual chlorine that may corrode stainless steel surfaces.

- Perform surface decontamination on the surfaces of any materials, containers or apparatus with appropriate disinfectant before entering or exiting the work area.
- Place the waste container (biohazard bag, pipette discard pans, etc.) inside the BSC work area.
- Place all items and apparatus in the safe working area.

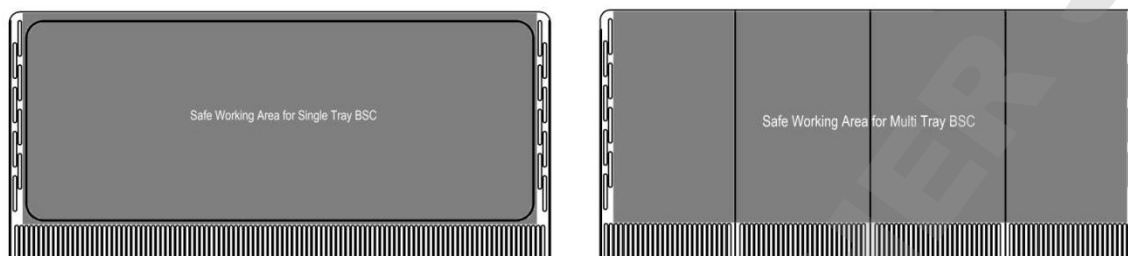

Figure 3.2. Safe Working Area

- Minimize room activities (personnel movements, closing and opening of doors, etc.) since these external airflow disturbances may adversely affect the BSC's internal airflow, thereby possibly impairing the containment capabilities of the BSC.
- Ensure that the sash is at normal operating height (READY state) before starting any experiment.
- Ensure the front and back air grilles are not obstructed by your arms or any other objects.
- Work as far back in the BSC as possible - at least 150 mm (6 inches) behind the front air intake grille.
- Wait for around one minute after placing the hands into the cabinet prior to any manipulation.
- While working in the BSC, move your hands slowly and in a controlled manner. Rapid movements may disrupt the air barrier, allowing contaminants to escape or enter the BSC.
- The use of bunsen burner inside the work zone is not recommended. However, if the use of bunsen burner is unavoidable, a burner that is capable of being used on demand or an enclosed electric micro incinerator may be used but they must be placed towards the back of the work surface in the BSC.
- Place aerosol-generating instruments as far back in the BSC as possible and at least 150 mm (6 inches) from clean items/materials.
- Place air turbulence generating equipment such as centrifuges, blenders or sonicators towards the back of the BSC. Stop other work while any of these equipment is in operation.
- As much as possible, it is recommended that the BSC be operated continuously in order to achieve optimal containment and cleanliness. Airflow studies have shown that once the fan has been switched off, air from the BSC may escape due to the thermal currents from inside the BSC. Therefore, it is recommended that post purge time is set to clear the work zone of contaminants after work in the BSC is completed. Air balance is an important consideration when determining the operation mode of the BSC since the air discharged through ducted BSC must be considered in the overall air balance of the laboratory.

3.4. Working Ergonomics

On most occasions, you would most likely be operating the BSC in a sitting rather than a standing position. There are some obvious advantages of the sitting position:

- The physiological energy cost and fatigue involved in sitting are relatively less.
- Sitting position provides the body with a stable support.

However, sitting position has some drawbacks too:

- The working area available is fairly limited.
- There is a potential risk of being constrained in the same posture for a long time.
- Sitting position is one of the most stressful postures for one's back.

Therefore, you should pay careful attention to the following guidelines in order to achieve comfortable and healthy working conditions:

- Always ensure that your legs have enough legroom.
- Keep your lower back comfortably supported by your chair. Adjust the chair or use an appropriate support (e.g. pillow) behind your back whenever necessary.
- You should place your feet flat on the floor or on a footrest. Don't dangle your feet and compress your thighs.
- You should vary your sitting position throughout the day at regular intervals so that you are never in the same posture for too long.
- Observe the following precautions with respect to your eyes:
 - Give your eyes frequent breaks. Periodically look away from the work area and focus at a distant point.
 - Keep your glasses clean.
- Arrange the items/apparatus frequently used in your work in such a way that you can minimize the physical strain involved in handling them.
- Exercise regularly.

The BSC's noise emission has been tested and found to be in compliance with EN 12469, ISO 4871 and NSF/ANSI 49 which is important to ensure health and comfort for the operator.

Ergonomics accessories available from Esco include:

- Armrest padding
- Lab chair
- Footrest

Please contact your local distributor or Esco for more information.

3.5. UV Lamps (If Present)

Shortwave UV (UVC) is considered as germicidal and virucidal. The UV lamp that Esco provides has a large portion of the spectrum in the UVC range. Unlike many other types of decontamination agent, UV light does not leave any residue. The decontamination action stops upon de-energizing of the lamp. However, the UVC spectrum does not penetrate well.

- UV light decontamination method may be used before and after working with susceptible organisms. However, it should not be the sole decontamination agent. Chemical decontamination agent should still be used.
- There should be minimal amount of material inside the BSC's work area during the process of UV light decontamination. A direct interaction with UV light can degenerate plastic or rubber-based material and can cause other hazards (e.g. Generation of hazardous vapors).
- Before activating the UV lamp, the BSC sash should be in fully closed position and the user should ensure that interlock is working properly. Avoid direct contact with skin and eyes as UV light is classified as a probable human carcinogen.
- The UV timer feature should be used to easily control the decontamination period (**Note: UV timer is disabled by default**). Leaving the UV lamp on for over 60 minutes or even overnight is not recommended because it shortens the lifespan of the lamp. The UV lamps used in Esco BSCs have a lifespan of 2,000 hours.
- The UV lamp should be cleaned of any dust and dirt weekly and changed annually to ensure its effectiveness. Ensure that the lamp is turned off when lamp cleaning and maintenance is carried out.
- *Please note that the use of UV lamp in a BSC has been explicitly discouraged in all major international standards and recommendations.*

3.6. Decontamination and Disinfecting Agents

- For stainless steel surfaces, all common disinfectant agents, except chlorine-based ones, are suitable. Where chlorine-based agents are used, sterile water should be used to wipe down the surfaces following the application of the disinfectant agents.
- For powder coated surfaces, all common disinfectant agents are suitable. However, the BSC has been specifically evaluated for use with the following:

- 1N Hydrochloric Acid
 - 1N Sodium Hydroxide
 - 1% Quaternary Ammonium Compound
 - 5% Formaldehyde
 - 5,000 ppm Hypochlorite
 - 2% Iodophor
 - 5% Phenol
 - 70% Ethyl Alcohol
- Adequate contact time should be observed for effective decontamination and the time required depends on the disinfectant agents, the concentration and the object of disinfection.
 - There is no one disinfectant agent that works with all organisms. Therefore, users and safety professionals should carry out risk assessment to ensure that appropriate disinfectant agents and validated decontamination procedures are used in decontaminating the BSC.

3.7. Gaseous Decontamination

Decontamination may frequently be carried out by means of formaldehyde fumigation or using other decontamination agents, such as chlorine dioxide or hydrogen peroxide. Decontamination process should only be carried out by qualified personnel.

In any of the following eventualities, the user should ensure that the BSC has been properly decontaminated, keeping in mind the nature of the pathogens used:

- At the time of moving/relocating the BSC
- At the time of changing the type of work being carried out in the BSC
- Before accessing contaminated areas for servicing (e.g. when filter needs replacement)
- Periodically and as mandated by your risk assessment

3.8. Further Information

- A Guide to Biosafety and Biological Safety Cabinets can be downloaded from <http://escoglobal.com/resource.php?id=13>
- An educational video on “Working Safely in your Biological Safety Cabinet” is available for viewing at <http://www.youtube.com/watch?v=ZnUW1N-JJz8>

Chapter 4 - Maintenance

4.1. Scheduled Maintenance

Proper and timely maintenance is crucial for trouble-free functioning of any device and your Esco BSC is no exception to this rule. We strongly recommend that you follow the maintenance schedule suggested hereunder in order to obtain optimal performance from your Esco BSC.

No.	Description of Task to Perform	Maintenance to be carried out every					
		Day	Week	Month	Quarter	1 Year	2 Years
1	Surface decontaminate the work zone	√					
2	BSC power-up alarm verification	√					
3	Perform thorough surface decontamination on the drain pan		√				
4	Check the paper catch for retained materials		√				
5	Clean UV lamp (where present) of any dust and dirt		√				
6	Clean the exterior surfaces of the BSC			√			
7	Clean the sash window			√			
8	Check all service fixtures (where present) for proper operation			√			
9	Inspect the BSC for any physical abnormalities or malfunction				√		
10	Clean stubborn stains on stainless steel surfaces with MEK				√		
11	Recertification					√	
12	Check the cabinet's functionality					√	
13	Change UV Lamp (where present)					√	
14	Change the fluorescent lamps						√

Cleaning the BSC

- Clean the work surface and walls with appropriate disinfectant and soap water afterward.
- Clean the sash window with appropriate disinfectant and glass cleaner afterward.
- Use a damp cloth to clean the exterior surface of the BSC, particularly on the front and top in order to remove dust that has accumulated there.
- Use sterile water to finish the cleaning and wash away any residue of disinfectant, soap, water and glass cleaner.
- For removing stubborn stains or spots on the stainless steel surface, make use of MEK (Methyl-Ethyl-Ketone). In such cases, make sure that you wash the steel surface immediately afterwards with sterile water and some liquid detergent. Use a polyurethane cloth or sponge for washing. Regular cleaning of the stainless steel surface helps retain the attractive factory finish.
- Ensure that the chemicals used are compatible with one another.
- Use appropriate personal protective equipment (PPE) when carrying out the activity.

Test the audible and visual alarm

The simplest method by far would be to move the sash until the glass window is no longer in the sash ready or UV mode position.

Check the cabinet's functionality

- Check the BSC's mechanical functionality (e.g. sash window – lubricate if necessary).
- Check the BSC's electrical functionality (e.g. fluorescent lamp – replace if necessary).
- Check the BSC for any defect and if any, repair immediately.

Recertification

All BSCs must be re-certified annually by a certified engineer. See certification procedures attached to the factory test report.

Accessing the paper catch

The purpose of accessing the paper catch is to remove any retained materials that might cause obstructions to airflow. Care must be taken as the area is contaminated.

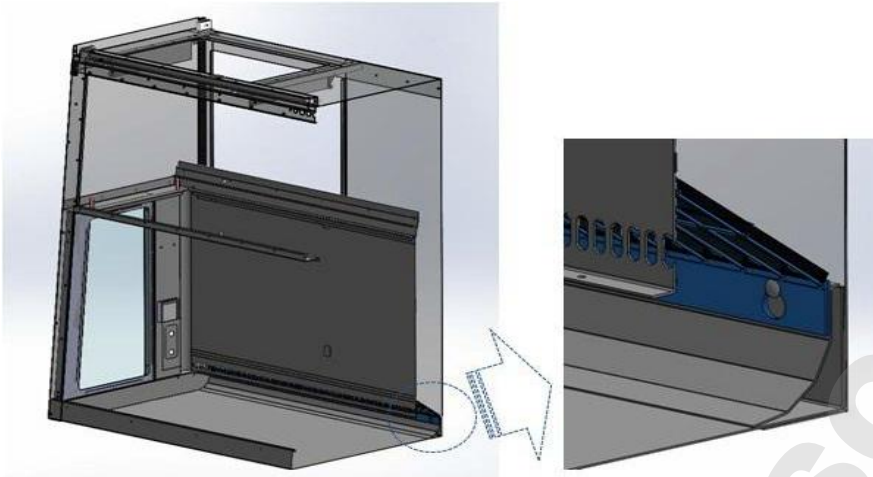

Accessing the paper catch:

1. Turn off the blower then raise the sash to fully open position for easy access.
2. Remove the tray(s) to access the paper catch.
3. As detailed, the paper catch is being hooked into two hooking objects at the back. Raise the paper catch initially up to 10mm until it feels like it disengages from those hooking objects, pull a bit to the front then do steps 1 to 3 below. Be careful of any sharp objects that might be present. You might want to use a mirror to help you assess the presence of hazardous materials prior to accessing the paper catch. Removed any materials that have been trapped.

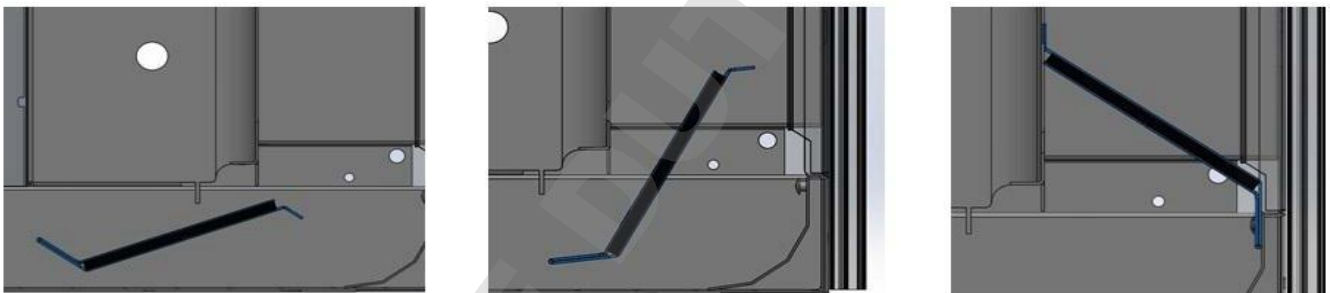
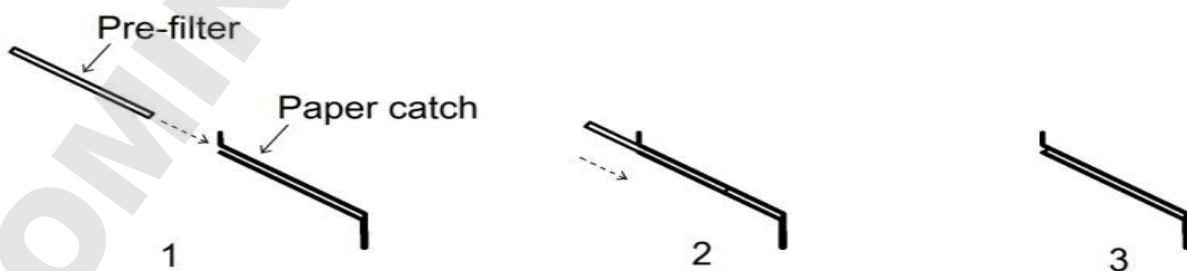

Figure 4.1. Paper catch access.

Pre-filter Installation:

1. Insert the pre-filter to the opening of the paper catch as shown in image 1 above.
2. Push the pre-filter accordingly until it fits into the paper catch as shown in image 2 to 3.

Figure 4.2. Installation of pre-filter.



Sash Cleaning Procedure for Non-Motorized Sash BSC

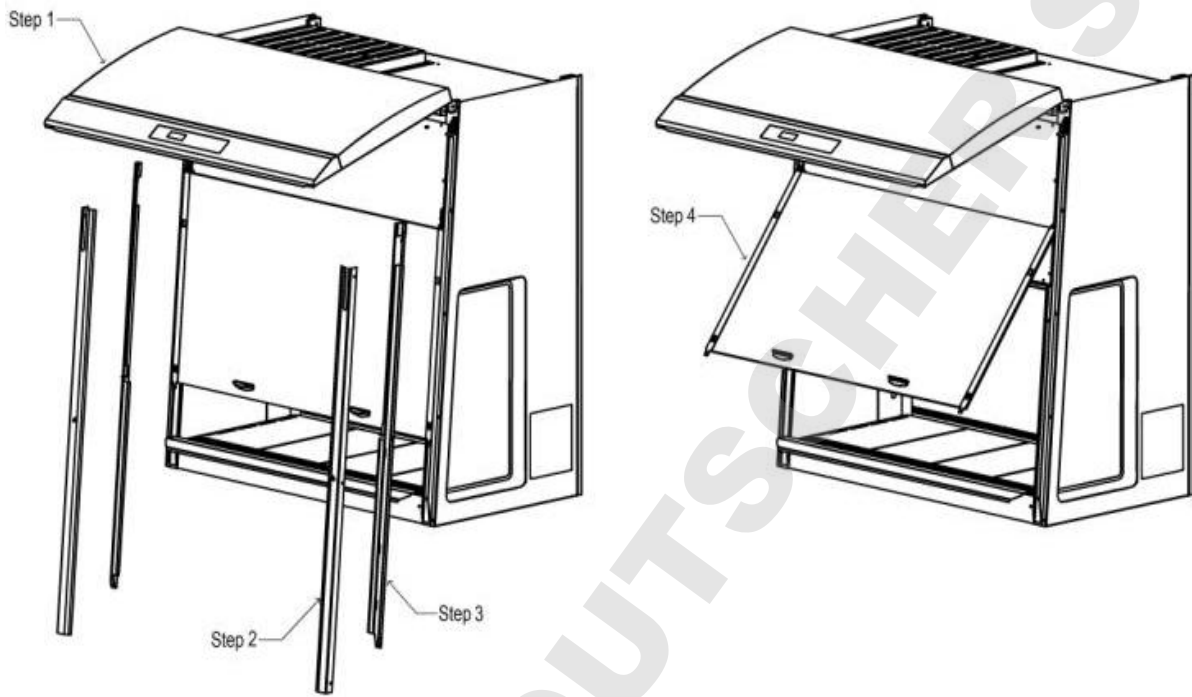

Steps in Sash Cleaning Procedure:

1. Tilt up the front panel.
2. Unscrew the two aluminum covers using Philip head screw driver.
3. Unscrew the two aluminum switch brackets using the Philip head screw driver.
4. Tilt up the sash glass freely for cleaning.

4.2. Maintenance/Service Log

It is good practice (and in some cases regulatory requirement) to maintain a log of all maintenance work carried out on your cabinet.

APPENDIX

DOMINIQUE DUTSCHER SAS

APPENDIX A: LOG RECORD

Cabinet : _____
Serial Number : _____
Person in Charge : _____

1. This log record should be used by the operator to record any new agent/virus/bacteria/germs that has been introduced to the cabinet during its operation, problems encountered, etc.
2. Any decontamination procedure performed by either the user or the technician should be recorded down as well.
3. Please also record any major maintenance procedure performed by the service technician, for example: parts replacement, recertification, etc.

Date	Event	User Signature	Supervisor Signature

In case of emergencies, please call:

Name : _____
Cell Phone Number : _____
E-mail : _____