

# LMS

## Cooled Incubators

### Models 410XAL & 610XAL

The LMS Models 410XAL & 610XAL Cooled Incubators are reliable and accurate temperature controlled cabinets (-10°C to +50°C) which have been widely used in laboratories throughout the world. These purpose built incubators with many applications, have specially built in features, particularly controlled lighting, making them ideally suited for a wide range of functions and applications:-

- B.O.D. Tests
- Seed germination & vernalisation
- Growth study of plants
- Insect culture
- Long-term stability study
- Controlled time-scale study

#### Models

410XAL (450 litres)

610XAL (600 litres)

#### Construction

Exterior – 410XAL white stove enamelled mild steel  
610XAL Stainless steel

Interior – White

Insulation – foamed polyurethane for optimum results

#### Special Features

Door Vents: two adjustable vents to allow for the exchange of air within the cabinet.

Temperature Protection: Adjustable temperature safety cut-out with two independent high/low points, giving both audible and visual alarms.

Lighting: 2 LED fittings mounted beneath adjustable shelves, complete with 24 hour timer with 10 minute resolution.

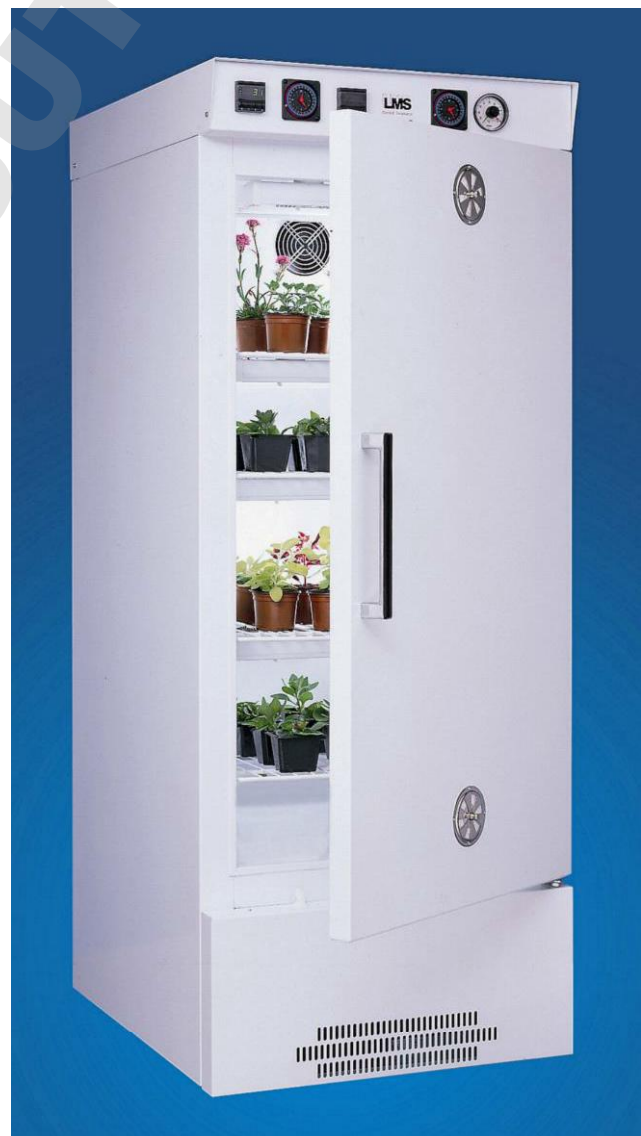

410XAL

Two Year Guarantee

## Design

- Digital control with digital readout
- Fan assisted air circulation via premixing chamber
- Full P.I.D. heating control to ensure stable internal temperature
- Pre-set 70°C safety cutout for total cabinet protection
- Electronics RF and TV suppressed
- Hermetically sealed refrigeration system
- Self-evaporating condensate drip-tray
- Automatic defrost
- Doorlock
- White plastic coated wire shelves
- RJ 45 interface
- Manual high/low temperature audible and visual alarm system with safety cut-out

## Operation

- Controls easy to read and simple to use  
Temperature range -10C to +50C with an average variation of  $\pm 0.5^{\circ}\text{C}$  and fluctuation of  $0.1^{\circ}\text{C}$  with an average workload.  
(Note: with illumination on range 0.0 to +50°C with an average variation of  $\pm 1.0^{\circ}\text{C}$ )
- Temperature set by direct reading digital controller
- Automatic Dual Temperature and Interior Lighting controlled by 24 hour or optional 7 day timer

## Optional Extras

- Built in chart recorder
- Access porthole
- Special evaporator for corrosive conditions
- Internal socket outlet
- Fully programmable controller

Model		410XAL	610XAL
External	Height	1810	2080
Dimensions	Width	690	740
	Depth	920	860
Capacity	(Litres)	450	600
Shelf Size	(MM)	510 x 600	510 x 600
Number of Shelves		4	5
Unladen Weight		130 Kgs	160 Kgs
Internal Dimensions (MM)	A	1170	1510
	B	700	680
	C	840	1370
	D	170	135
	E	280	420
	F	72	90
	G	405	420
	H	250	180
	J	51	35
	K	550	600

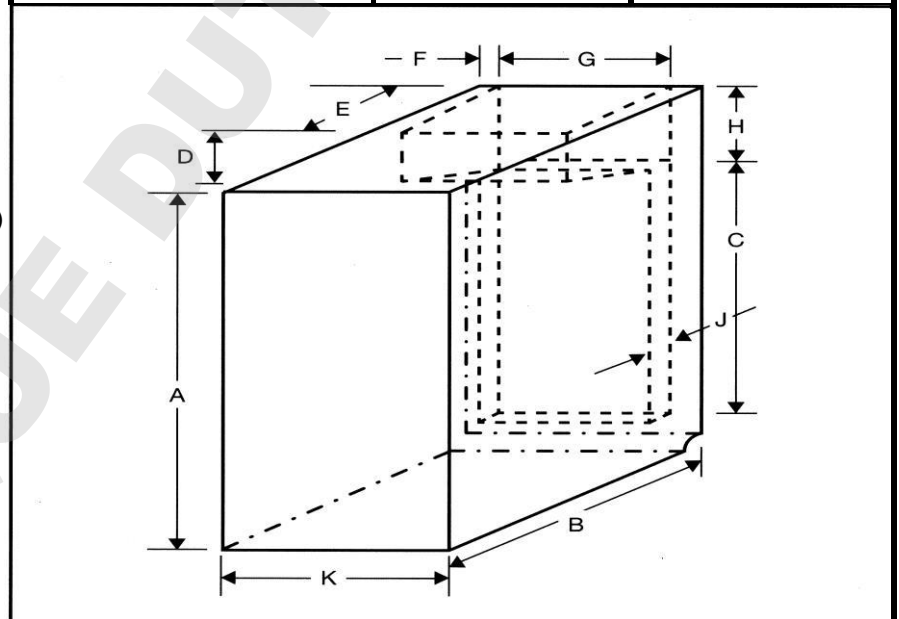

LMS Limited reserve the right to amend the specification of all models without prior notice in the light of changing user techniques.

The standard voltage is 240v 50Hz but other volts/cycles are available.



The Modern Forge, Riverhead, Sevenoaks, Kent TN13 2EL  
Telephone: 01732 451866 Facsimile: 01732 450127