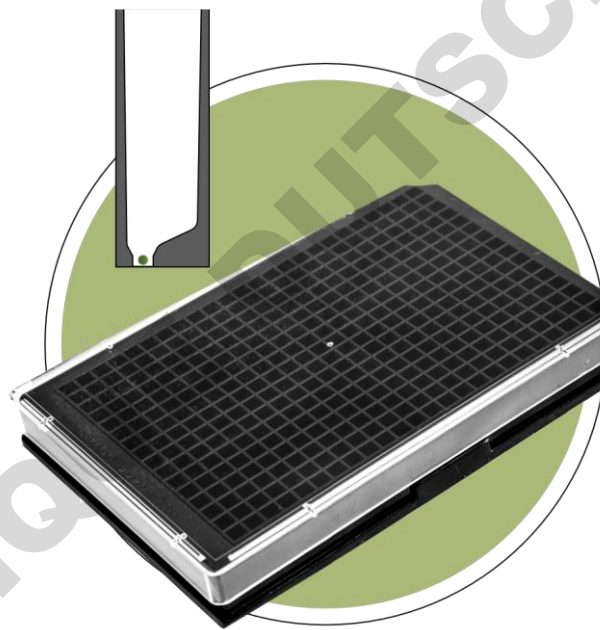




Akura™ 384 Spheroid

Microplate

Technical Specifications



SPEC007, February 2024

Akura™ 384 Spheroid Microplate Specifications

Article number:	CS-PC24
Product name:	Akura™ 384 Spheroid Microplate
Pack size:	10x Akura™ 384 Plates with lid, sterile, ultra-low attachment (ULA) coated wells
Plate & lid material:	Black-walled Polystyrene body bonded to transparent, continuous, 125 µm Polystyrene membrane, Polystyrene lid
ULA coating:	ULA coated Akura™ plate surfaces are hydrophilic, neutrally charged and promote the formation and long-term maintenance (>4 weeks) of 3D cell cultures.

Plate Dimensions:

Plate length:	127.76 mm
Plate width:	85.48 mm
Height of plate:	14.35 mm
Height of well:	11.71 mm
Skirt height:	2.52 mm
Diameter well bottom:	1.00 mm
A1 to top offset:	9.89 mm
A1 to side offset:	12.05 mm
Well center to cavity center offset:	0.90 mm
Working volume:	40-50 µl
Well-to-well distance:	4.5 mm
Thickness PS membrane:	0.125 mm
Refractive index of PS membrae:	1.515

Product Description:

The Akura™ 384 Plate format is compliant with standard microplate definitions as specified by the SLAS Microplate Standards Advisory Committee ANSI SLAS 1-2004 (R2012). The 384 wells are arranged in 16 rows and 24 columns, identified by alphanumeric well markings on the left side from top to bottom (A-P) and on the top from left to right (1-24). Plate orientation notches are located at the A1 and P1 well corners (Figure 1A). Individual wells show a regular wide opening at the top narrowing down into a small, asymmetric cavity at the well bottom, with a flat optically clear base (Figure 1B), designed to accommodate spheroids of up to 1 mm in diameter. Spheroids in wells can be observed using standard imaging equipment (Figure 1C, D). The Akura™ 384 Spheroid Microplate Technical Specifications provides additional details about plate design and dimensions (Figure 2-4).

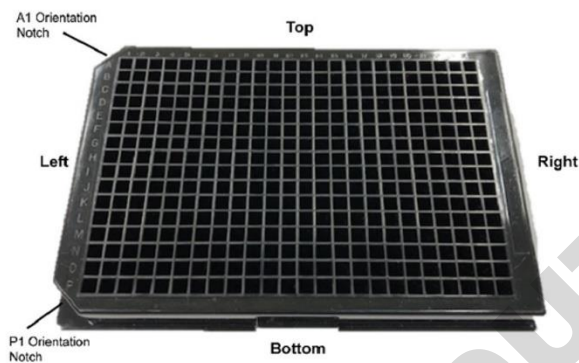
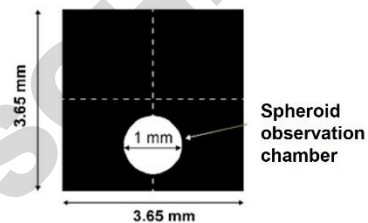
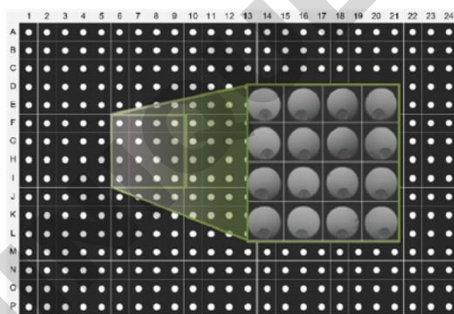
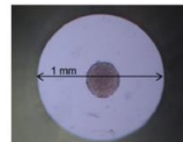
A Akura™ 384 Plate design**B Well dimensions and spheroid position****C Imaging scans of spheroids in wells****D Spheroid in 1 mm observation chamber**

Figure 1: A. Akura™ 384 Plate. B. Overhead view of well dimensions and 1 mm spheroid observation chamber. C. Imaging scan of an Akura™ 384 Plate shows one spheroid per well and the position of each spheroid within the observation chamber. D. Image of a spheroid within the 1 mm spheroid observation chamber.

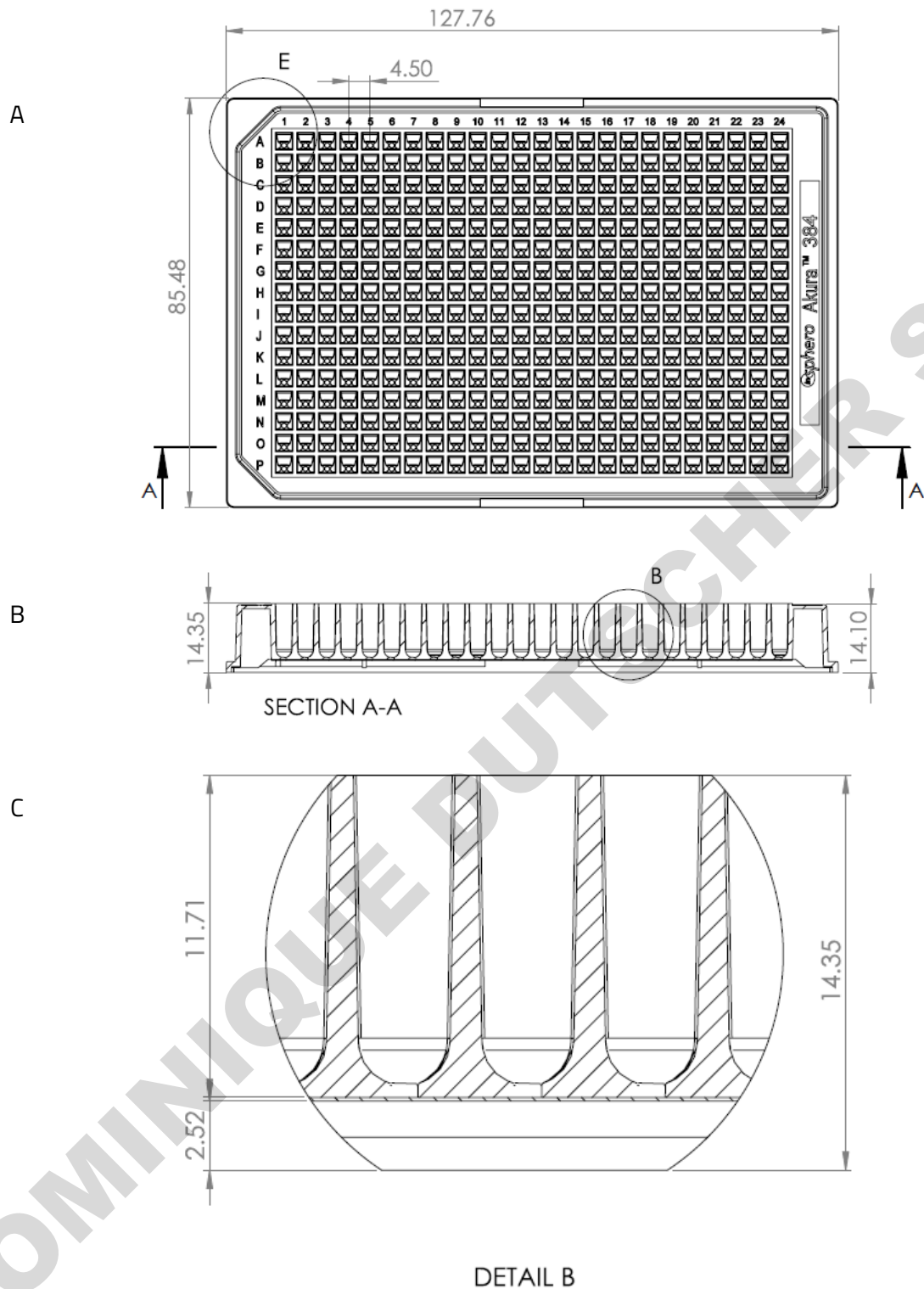
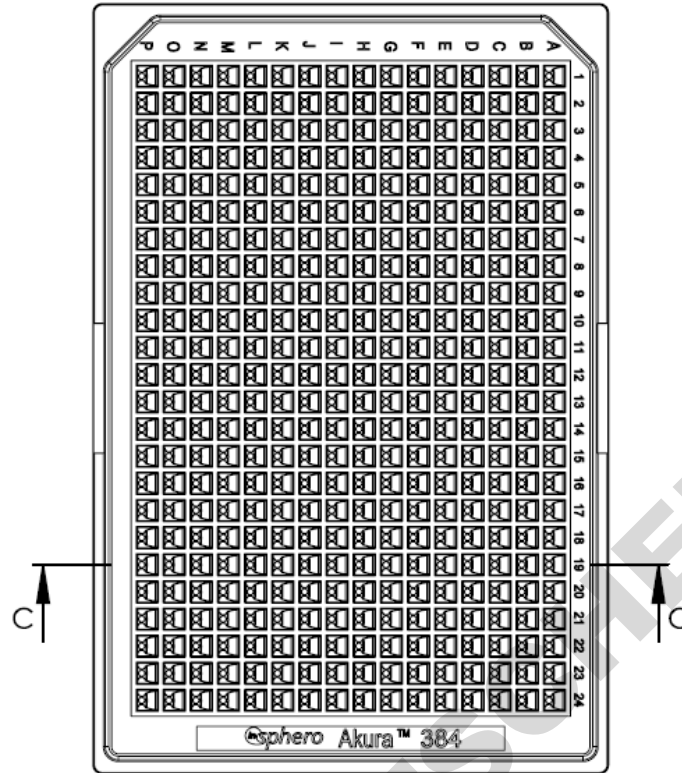
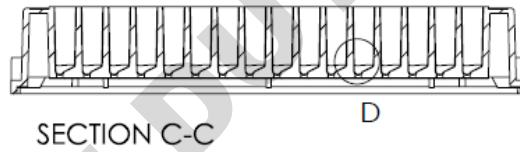


Figure 2: A. Plate layout. B. Row cross section with plate height and C. Skirt height (distance between plate bottom and rim) and plate height (skirt height plus membrane thickness plus well height).

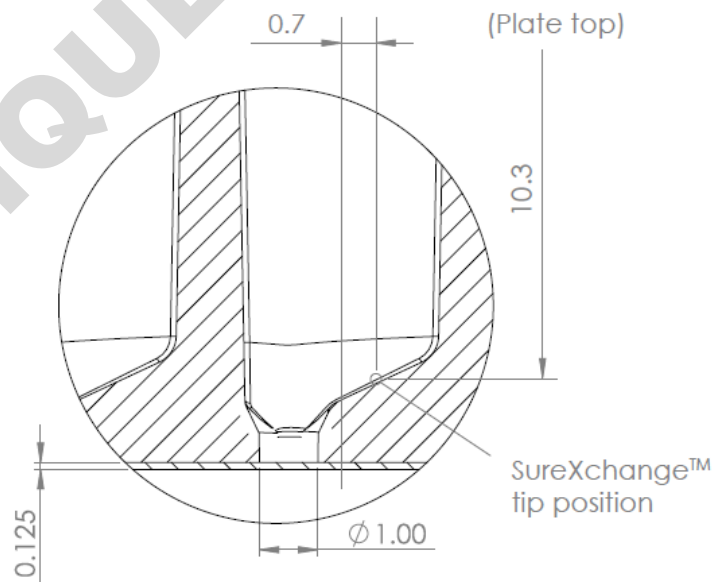
A



B



C



DETAIL D

Figure 3: A. Vertically oriented plate layout. B. Row cross section and C. Well cross section with SureXchange™ tip position in mm.

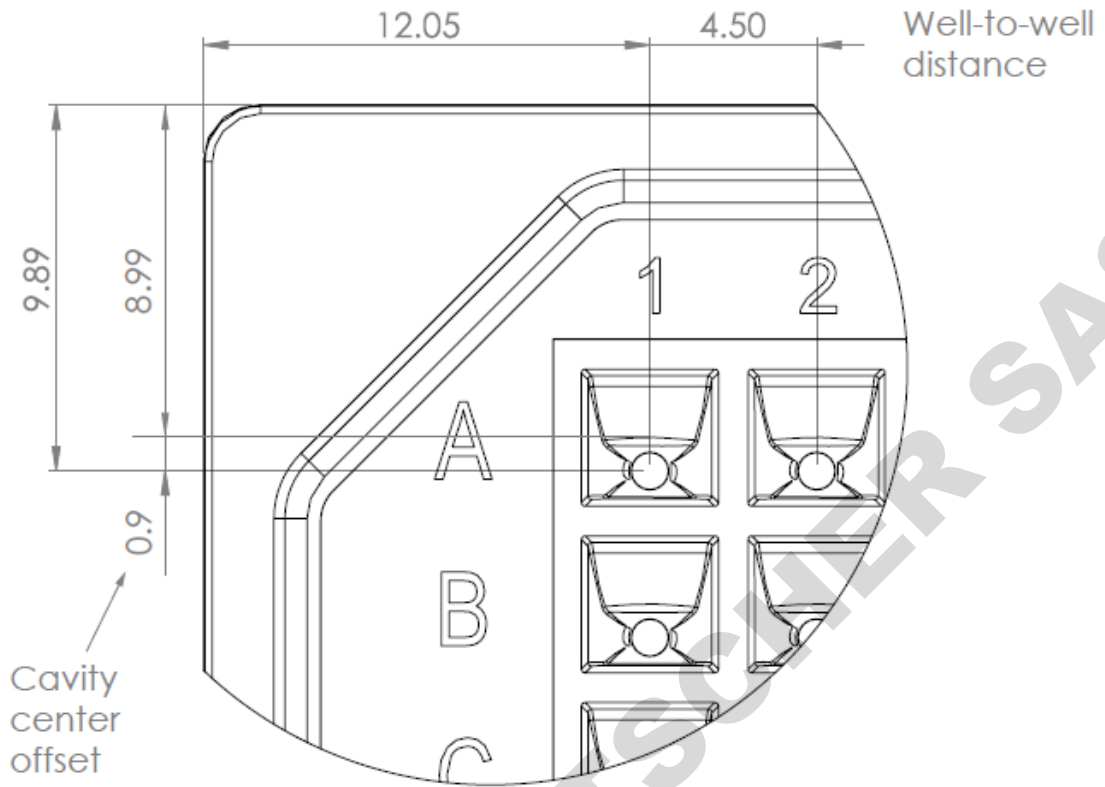


Figure 4: Top-down view showing cavity center offset.

Akura™ 384 Spheroid Microplate restrictions:

The skirt height of the Akura™ 384 Plate is 2.52 mm. The skirt height is the distance between the well bottom (the 125 µm membrane) and the plate skirt (Figure 5). This design may restrict certain high NA objectives and immersion objectives to reach the outer wells of the plate.

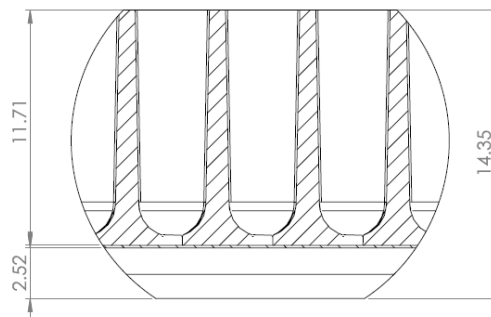


Figure 5: A. Fluorescent ring around well in DAPI/Hoechst channel. B. Skirt height of 2.52 mm does not allow high NA and water immersion objectives to be used for outer wells.

DOMINIQUE DEUTSCHER SAS



InSphero AG
Schlieren, Switzerland

InSphero Inc.
Brunswick, ME, USA

If you have more questions, please refer to
the FAQs section on shop.insphero.com

Sign up for latest news and updates at
insphero.com/newsletter

Follow us on LinkedIn and Twitter

InSphero is ISO 9001:2015 certified

All rights reserved, © 2021 InSphero AG.
3D InSight, Akura and InFloat are
trademarks of InSphero AG. For life
science research only. Not for use in
diagnostic procedures.