

THE INFORMATION CONTAINED IN THIS DRAWING IS PROPERTY OF ARVENSIS LTD. ANY REPRODUCTION IN PART OR WHOLE WITHOUT THE WRITTEN PERMISSION OF ARVENSIS LTD IS PROHIBITED. UPON RECEIPT OF WHICH IT IS THE USERS RESPONSIBILITY TO SEEK CONFIRMATION OF ANY DIMENSIONS AND TOLERANCES.

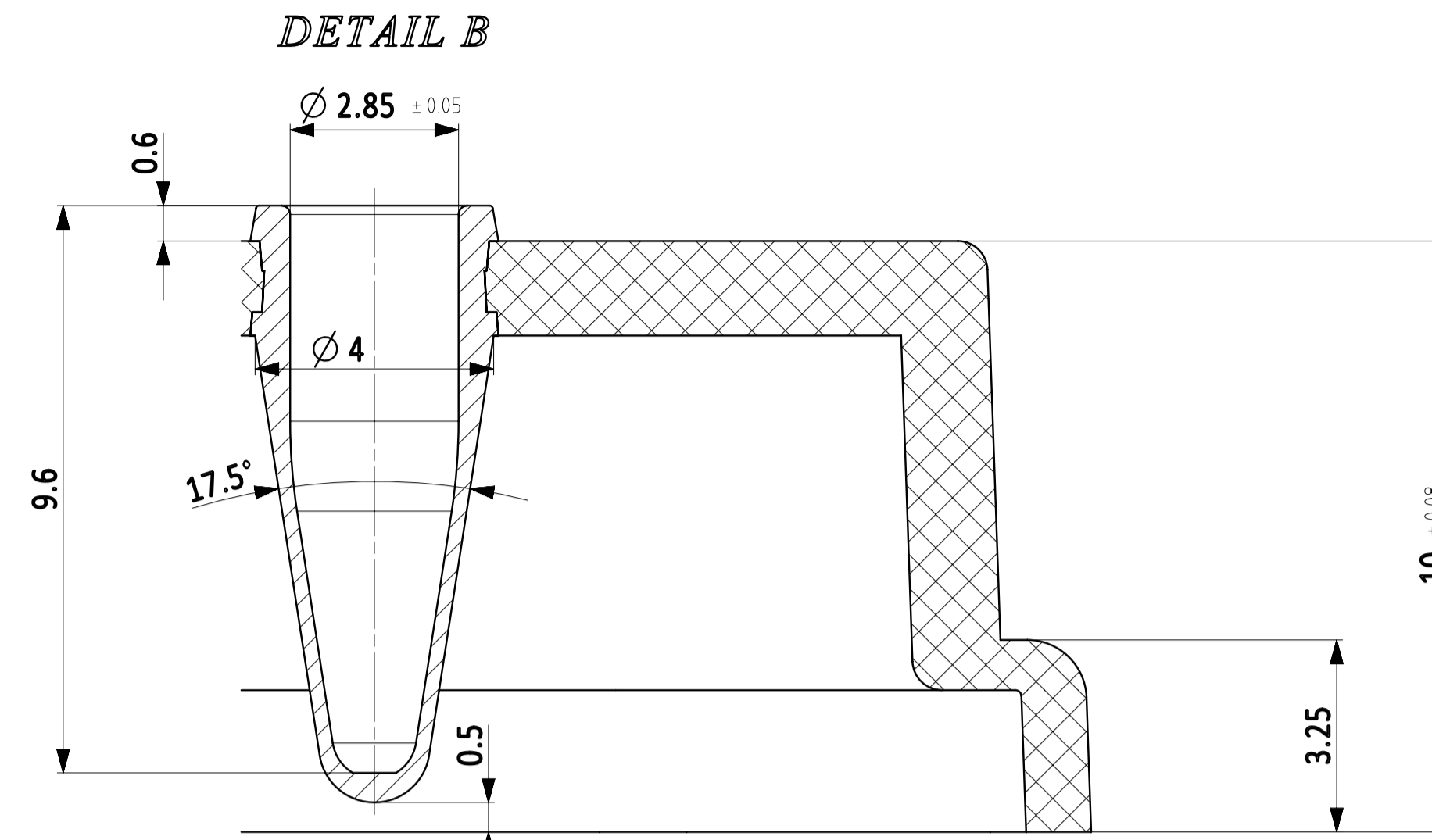

Maximum well capacity:
46uL

ALL GRID REFERENCES ARE HOT FOILED

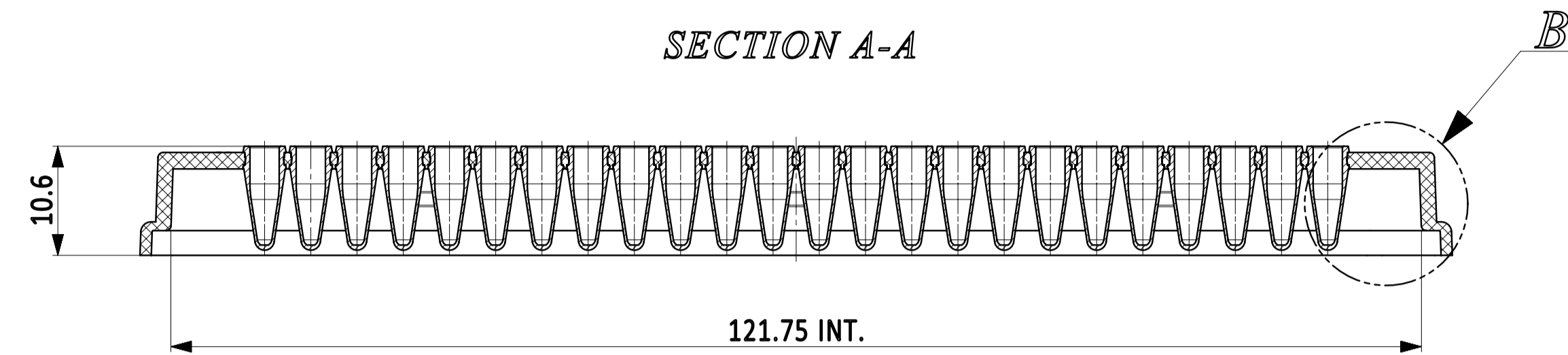
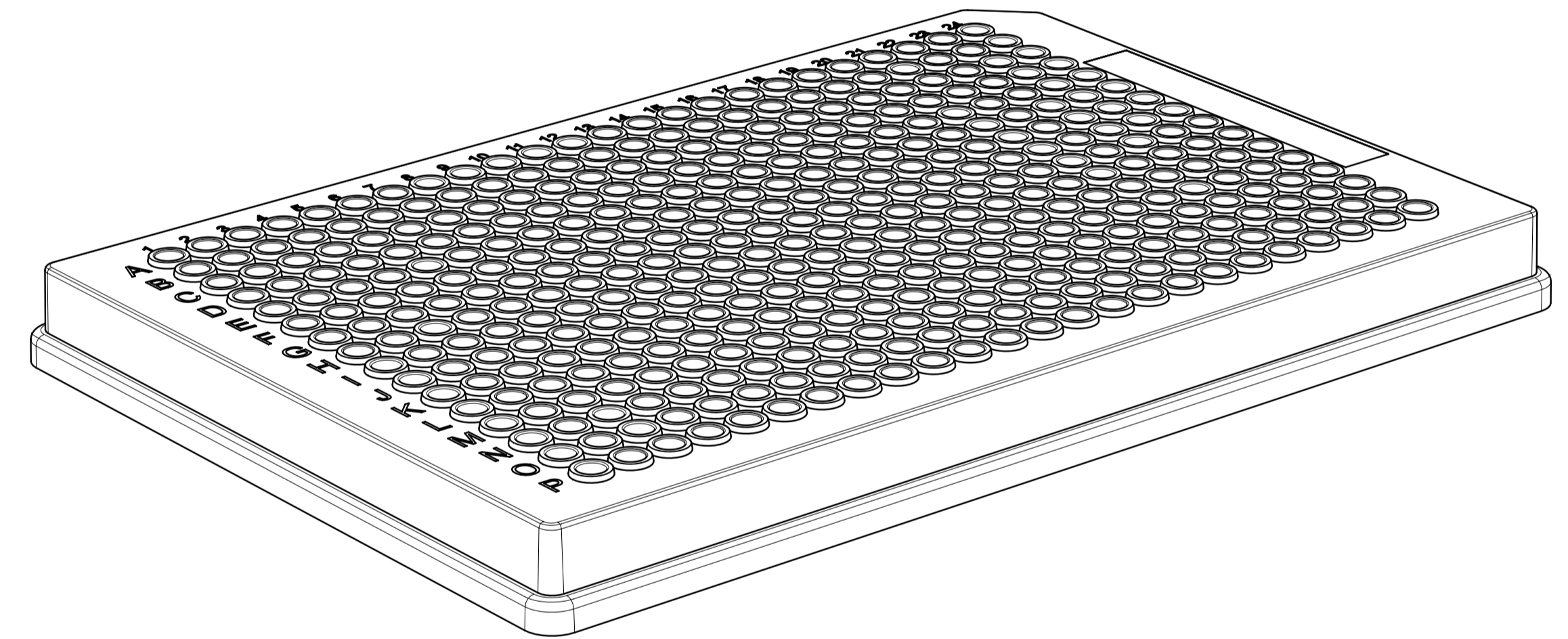
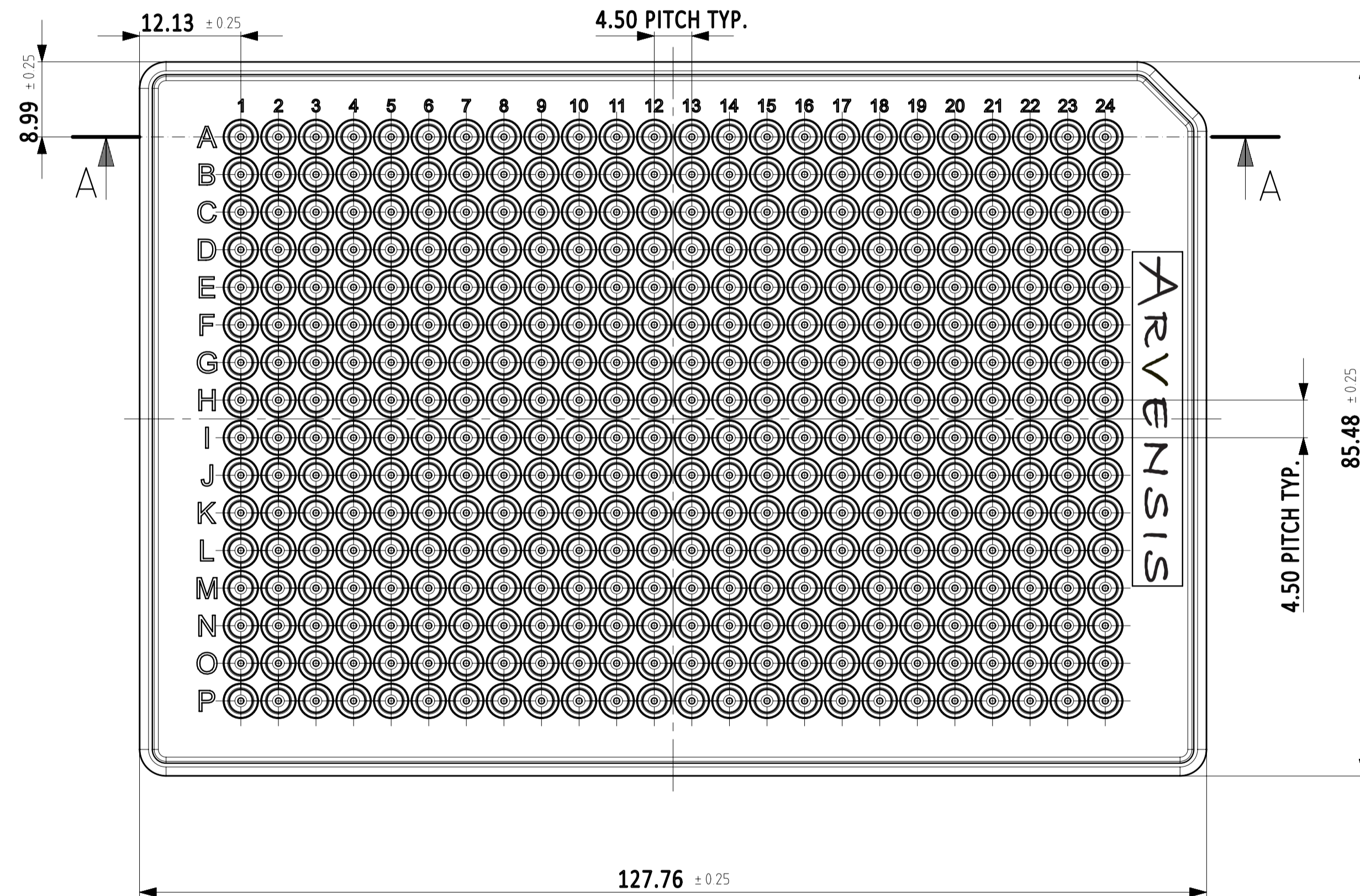

MARKETING DRAWING

REV	DATE	DESCRIPTION OF CHANGE	Changed by	Project	Designer	GENERAL TOLERANCES		DIMENSIONS NOT SHOWN ON DRAWING ARE CONTROLLED BY 3D CAD FILE		ARVENSIS	
				Customer	Drawn date	Dimension rank	Tolerance	DO NOT SCALE PRINTS UNLESS OTHERWISE SPECIFIED ALL DIMENSIONS ARE IN MM		Title	
				Material	21.12.2021	Angular	± 0.25°	FIRST ANGLE PROJECTION		Arvensis 384 Well PCR Plate, Fully Skirted, A24 cut corner, 45uL wells	
				Finish	Approved by	0-6	± 0.05	CAD file		Drawing no	
				SEE NOTES	Paul Day	6-30	± 0.10	AR-006-TF384_v2_rev_8_MARKETING.prt		Revision	
				SEE NOTES	Sheet 1 OF 1	30-120	± 0.15	AR-006-TF384_v2_rev_8_MARKETING.prt		AR-006-TF384_v2_rev_8_MARKETING	
					Scale	120-315	± 0.25	AR-006-TF384_v2_rev_8_MARKETING.prt		8	
					Size			AR-006-TF384_v2_rev_8_MARKETING.prt			
								AR-006-TF384_v2_rev_8_MARKETING.prt			