

## 13 x 100mm (8mL Capacity) Test Tubes

Item# 110415 / 110445



### Description

These Globe Scientific test tubes are molded from premium grade polystyrene (PS) for clarity or polypropylene (PP) for impact strength and stability to common acids, alkalies, and solvents. The polystyrene tubes can withstand 1500 RPM during centrifugation. The polypropylene tubes can withstand 3000 RPM and are autoclavable and freezable.

### Features

- 8mL capacity
- 13 x 100mm
- Available in polystyrene (PS) or polypropylene (PP)
- Non-graduated

### Technical Specifications

#### Polystyrene Tubes:

Spin Rate: 1500 RPM  
 Autoclavable: No  
 Brittleness temperature: 20°C  
 Maximum temperature: 90°C  
 Sterility: Non-sterile

#### Polypropylene Tubes:

Spin Rate: 3000 RPM  
 Autoclavable: Yes  
 Brittleness temperature: 0°C  
 Maximum temperature: 135°C  
 Sterility: Non-sterile

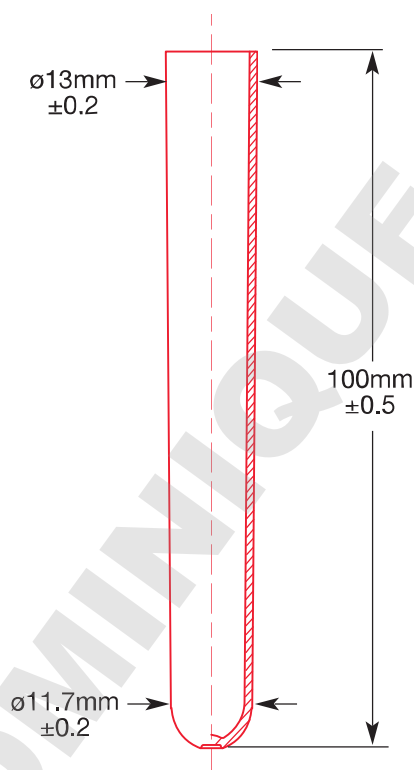

### Products

Item#	Description	Unit
<b>110415</b>	8mL test tube, PS	1000
<b>110445</b>	8mL test tube, PP	1000