

Description (Class):
Reference, Customer Technical Data Sheet
Cell Culture Flask, 25 cm² canted neck, plug seal cap. Total Volume = 70 mL

Page:
1 of 2

APPLICATIONS:

- Cell culture
- Sample or reagent storage

FEATURES:**Polystyrene construction**

- Optically clear for easy viewing of sample or cells
- Stable from 4°C to 60°C
- Frosted writing patch for easy labeling

Choice of surface

- Tissue culture treated plastic (TC) provides a hydrophilic surface to promote cell attachment (Cat. No. 353082)
- Untreated plastic is hydrophobic. Ideal for non-adherent cell cultures (Cat. No. 353009)

Two-position plug seal cap

- Biologically inert, high density polyethylene provides a chemically resistant surface
- Cap can be loosely closed to allow gas exchange
- Further tightening snaps cap into sealed position that is liquid-tight
- A reference bar on the outside of the cap can be aligned with flask markings for precise incubation conditions

Molded graduations along both sides of flasks

- Graduated at 5 mL increments to 50 mL
- Allows quick volume estimation

Prominent stacking rims along perimeter of upper surface

- Permits easy interlocked stacking in incubator or culture hood
- Flasks will not slip off one another while being transported

Tissue culture-friendly packaging

- Convenient reseal tab on the bag
- Innovative bag materials that will not scuff or scratch the flask surface
- Double-wall bags provide increased sterility assurance
- Medical-style peel-open bags guarantee that sterility is maintained as flasks are removed from the bag
- Recyclable bag material (low density polyethylene)

STERILITY:

Product is gamma irradiated.

REGULATORY COMPLIANCE:

Falcon[®] products are manufactured under the current ISO 9001 and ISO 13485 Standards, and the current FDA Quality System Regulation 21 CFR Section 820.

RESTRICTIONS:

- Refer to "Thermoplastics Properties Chart," available at:
http://catalog2.corning.com/Lifesciences/media/pdf/an_DL_226_Falcon_ThermoPlastics_Broch.pdf

Description (Class):
Reference, Customer Technical Data Sheet
Cell Culture Flask, 25 cm² canted neck, plug seal cap. Total Volume = 70 mL

Page:
 1 و 2

Material: Polystyrene

Related Catalog Numbers:

Cat. No.	Packout Description	Cap	Neck Style	Graduations	Surface
353009	20/Bag, 200/Case	White Plug Seal	Canted	Numeric/molded	Nontreated
353082	20/Bag, 200/Case	Blue Plug Seal	Canted	Numeric/molded	Standard TC

Dimensions = mm (inches)

FLASK
 A = w/cap 97.94 (3.856)
 w/o cap 93.44 (3.679)
 B = 55.22 (2.174)
 C = 26.11 (1.028)
 D = w/cap 28.67 (1.105)
 w/o cap 26.11 (1.028)
 E = 77.14 (3.037)

GROWTH AREA = 25 cm²
VOLUME = 70 mL

NECK
 ID = 15.11 (.595)
 Length = 16.30 (.642)

CAP, Material: High Density Polyethylene

F = O.D. 23.36 (.920)
 G = 16.84 (.663)

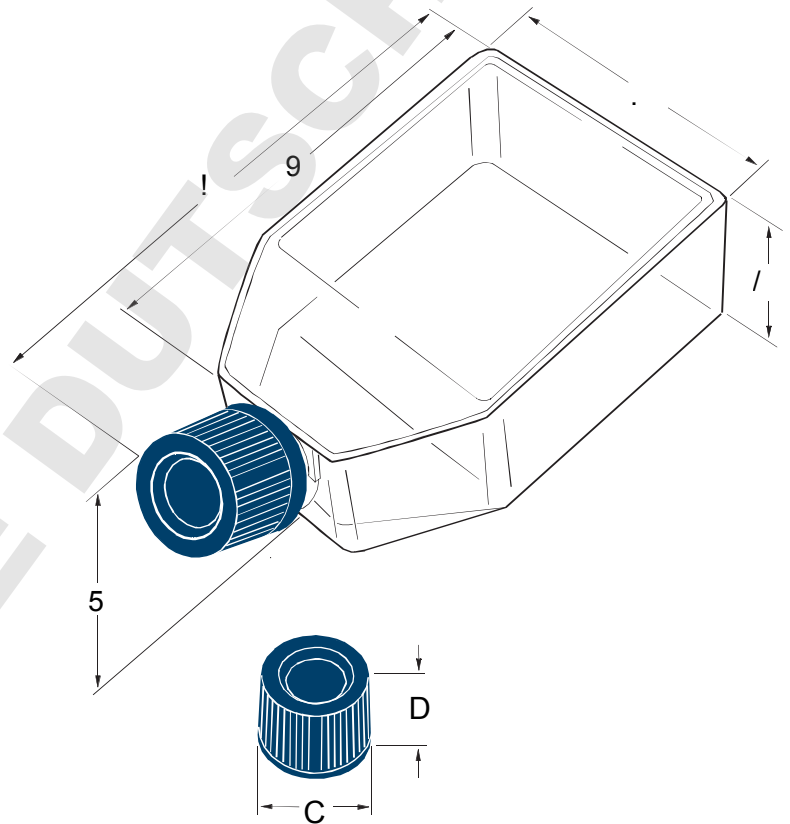

Warranty/Disclaimer: Unless otherwise specified, all products are for research use only. Not intended for use in diagnostic or therapeutic procedures.