

ULTRA LOW PARTICULATES

USP788 ✓
EP 2.9.19 ✓
JP 14th ed. part 1 sect. 24 ✓

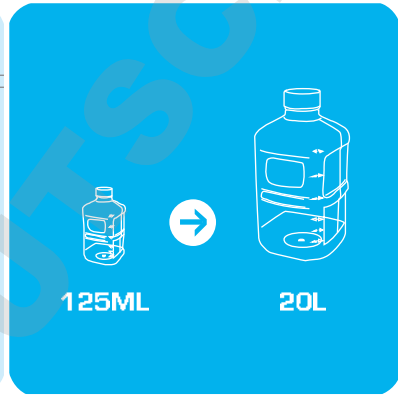
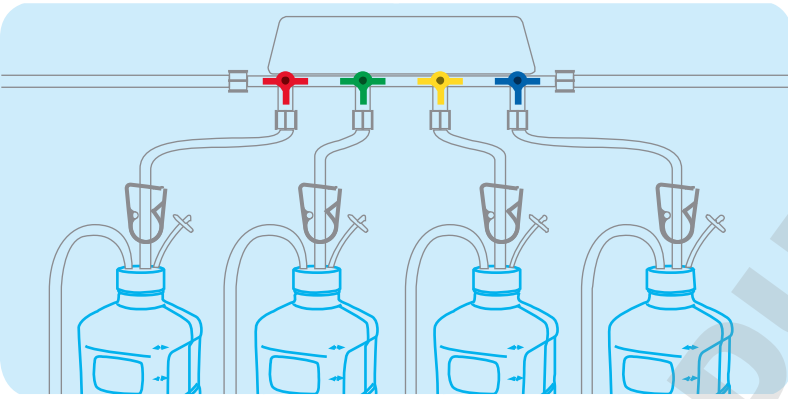

The new standard in single-use containers for storage and transport of vaccines, biopharmaceuticals, culture media and other biotech materials.

Clean, sterile & ready to use

Comprehensive validation file available

Medically approved resins

Molded and capped in an **ISO CLASS 5 (class 100) environment**

Certified by lot to meet USP788, EP and JP compendia standards for particulates in injectables

Unrivalled **traceability** throughout production and during use

Precision, injection molded, flash and burr free neck finish

PET PharmaTainers, 125ml to 20L have excellent **gas barrier properties**

PC PharmaTainers, 125ml to 20L are ideal for **freezing applications**

DOUBLE SEAL CLOSURE SYSTEM



Precision molded closures and necks have robust threads that provide secure engagement between cap and bottle. Closures seal at two points; inside the neck and on the rim of the neck to provide a leak proof seal.

MANUFACTURED FROM 100% VIRGIN, MEDICALLY APPROVED, ANIMAL DERIVED COMPONENT FREE (ADCF) RESINS.

CERTIFIED TO MEET USP788 FOR PARTICULATE.

MOLDED AND CAPPED IN AN ISO CLASS 5 (CLASS 100) ENVIRONMENT.

PACKED IN AN ISO CLASS 7 (CLASS 10,000) CLEANROOM.

UNLINED, DOUBLE SEAL CLOSURE SYSTEM.

PRECISION, INJECTION MOLDED NECK IS FREE OF FLASH AND OTHER IMPERFECTIONS.

EACH CONTAINER IS PRINTED WITH A UNIQUE SERIAL NUMBER, BATCH NUMBER, EXPIRATION DATE AND MACHINE READABLE DATA MATRIX FOR UNRIVALLED TRACEABILITY.



RAW MATERIALS

PharmaTainer™ products are manufactured from 100% virgin ADCF resins that are approved by our suppliers for medical applications and selected by Cella for their performance, clarity and biocompatibility.

Bottles and Carboys are manufactured from polyethylene terephthalate (PET) and polycarbonate (PC). Closures are manufactured from natural (non coloured) high density polyethylene (HDPE).

All raw materials are supported by drug master files held by the FDA. All raw materials meet the following requirements.

	PET	PC	HDPE
Approved for medical use	Yes	Yes	Yes
USP Class VI	Yes	Yes	Yes
In vitro cytotoxicity test	Yes	Yes	Yes
Drug master file	DMF15205	DMF1562	DMF1646
ADCF*	Yes	Yes	Yes

*Animal derived component-free

Resin identity is confirmed by (FTIR) Fourier transform infrared spectroscopy analysis for all resin lots prior to release into the manufacturing process.

TRACEABILITY



Each container is printed with a unique serial number, lot number, expiration date and machine readable data matrix to provide unrivalled traceability through the production process at Cella and during use at your facility.

CERTIFIED TO MEET USP788 STANDARDS FOR PARTICULATE

Every batch of PharmaTainers is tested using liquid particle count technology and certified to meet USP788, EP 2.9.19 and JP 14th edition part 1 section 24 criteria for particulate in injectable liquids i.e.

Liquid particle count limits, USP788, EP, and JP Compendia

Particle size	≥10 µm	≥25 µm
Container working volume >100ml	25/ml	3/ml

MANUFACTURING



PharmaTainer™ bottles are manufactured in our state-of-the-art facility dedicated to the production of sterile single use products for use in biotech industries. Single-use containers eliminate cross over contamination from failure to clean in reusable containers, and also eliminate the possibility of contaminants that may be present when non-sterile, general purpose products and sterile disposable products are manufactured in the same facility.

Production is by an injection blow molding process that produces bottles with a precision, flash-free, burr-free neck, eliminating the primary cause of seal failure.

Uniform bottle walls provide strong, freezer safe and break resistant containers. An extensive, ongoing quality control program ensures uniformity of production and conformity to our exacting manufacturing specifications.

Molding and capping operations are performed in a ISO Class 5 (Class 100) environment minimising the possibility of particulate, bioburden or endotoxin inside the container. Caps are applied mechanically, with a consistent torque to ensure a seal between the cap and container.

Bottles and carboys are printed with clear, easy to read black graduations, accurate to +/- 2%.

VALIDATION DOCUMENTATION

The PharmaTainer product line is supported by a comprehensive validation file available on CD from Cellon. Please contact us at sales@cellon.lu to receive your copy

PACKAGING



PharmaTainer™ products are packed in an ISO Class 7 (Class 10,000) clean room to minimise the impact of particulate from packaging in your controlled environments. Products are shipped in cartons with 3 layers of internal packaging to aid delivery into your clean room manufacturing areas. The innermost packing layer is vacuum sealed to provide assurance of an intact sterility barrier. The second bag is heat sealed and the third bag (carton liner) is folded and tape closed. Clear labelling of all levels of packaging simplifies your inventory control and enhances traceability throughout your processes

MANUFACTURING PRODUCTION RECORDS



Comprehensive production records are collated and maintained for each PharmaTainer™ production lot, including raw material certificates, FTIR scan test results, machine and operator details for all production stages, QC records, sterility and endotoxin test certification. Samples of all raw material lots and final product lots are retained for future reference if required

STERILITY



PharmaTainer™ product family sterility certification is based on a VD_{max}^{26} sterilisation study performed according to "ISO11137-2:2007, VD_{max}^{26} sterilisation of health care products- radiation-part 2", which demonstrates that a 25kGy irradiation dose achieves a sterility assurance level (SAL) of 10⁻⁶.

Ongoing sterility assurance is maintained by bioburden assessments on every product batch and quarterly VD_{max}^{26} dose audit studies.

ENDOTOXIN



Endotoxin testing is carried out as part of product release criteria for each manufacturing lot. The test is carried out by an independent laboratory by means of a validated assay method using a 5% rinse volume and a detection limit of 0.001EU/ml that complies with current USP and EP bacterial endotoxin test (BET) methodologies. The tests demonstrate no detectable endotoxin.

QUALITY SYSTEM, PRODUCT CERTIFICATION, CUSTOMER AUDITS

Cellon business operations and manufacturing processes conform to ISO 9001: 2008. There is a formal change notification policy to provide advance notice in the event of a necessary product change.

Each lot of PharmaTainer™ bottles is certified to meet our exacting production specifications.

Cellon welcomes the opportunity to showcase its manufacturing facility for customers who wish to conduct a plant tour or full production and process audit.

PORTED CAPS



A range of 2,3 and 4 ported caps with hose barbs suitable for use with silicone, thermo-elastomer and PVC tubing, specifically designed for use with the PharmaTainer™ range is available. Please contact us for details.

PRODUCT SPECIFICATIONS

CATALOGUE NUMBER	SPECIFIED VOLUME	MAXIMUM VOLUME	BOTTLE MATERIAL	CLOSURE TYPE	BOTTLE DIMENSIONS H x W x D	CARTON DIMENSIONS MM	QTY PER PACK/CASE
200125-05	125ml	190ml	PC	49mm HDPE	95 x 58.8 x 58.2 mm	L620 x W340 x H270	5/100
200125-01	125ml	190ml	PC	49mm HDPE	95 x 58.8 x 58.2 mm	L520 x W285 x H530	1/48
200500-05	500ml	635ml	PC	49mm HDPE	152 x 83.2 x 83.2 mm	L530 x W450 x H380	5/60
200500-01	500ml	635ml	PC	49mm HDPE	152 x 83.2 x 83.2 mm	L520 x W285 x H530	1/36
201000-05	1,000ml	1,200ml	PC	49mm HDPE	187 x 101 x 101 mm	L358 x W548 x H448	5/30
201000-01	1,000ml	1,200ml	PC	49mm HDPE	187 x 101 x 101 mm	L520 x W285 x H530	1/24
202000-05	2,000ml	2,270ml	PC	49mm HDPE	240 x 120 x 120 mm	L630 x W515 x H300	5/20
202000-01	2,000ml	2,270ml	PC	49mm HDPE	240 x 120 x 120 mm	L520 x W285 x H530	1/14
205000-01	5,000ml	5,900ml	PC	70mm HDPE	322 x 168 x 168 mm	L590 x W400 x H350	1/6
210000-01	10,000ml	11,600ml	PC	70mm HDPE	395 x 212 x 212 mm	L458 x W248 x H458	1/2
220000-01	20,000ml	22,800ml	PC	70mm HDPE	500 x 256 x 256 mm	L590 x W330 x H570	1/2

CATALOGUE NUMBER	SPECIFIED VOLUME	MAXIMUM VOLUME	BOTTLE MATERIAL	CLOSURE TYPE	BOTTLE DIMENSIONS H x W x D	CARTON DIMENSIONS MM	QTY PER PACK/CASE
100125-05	125ml	196ml	PET	49mm HDPE	95 x 58.8 x 58.2 mm	L620 x W340 x H270	5/100
100125-01	125ml	196ml	PET	49mm HDPE	95 x 58.8 x 58.2 mm	L520 x W285 x H530	1/48
100500-05	500ml	635ml	PET	49mm HDPE	152 x 83.2 x 83.2 mm	L530 x W450 x H380	5/60
100500-01	500ml	635ml	PET	49mm HDPE	152 x 83.2 x 83.2 mm	L520 x W285 x H530	1/36
101000-05	1,000ml	1,213ml	PET	49mm HDPE	187 x 101 x 101 mm	L358 x W548 x H448	5/30
101000-01	1,000ml	1,213ml	PET	49mm HDPE	187 x 101 x 101 mm	L520 x W285 x H530	1/24
102000-05	2,000ml	2,295ml	PET	49mm HDPE	240 x 120 x 120 mm	L630 x W515 x H300	5/20
102000-01	2,000ml	2,295ml	PET	49mm HDPE	240 x 120 x 120 mm	L520 x W285 x H530	1/14
105000-01	5,000ml	6,000ml	PET	70mm HDPE	322 x 168 x 168 mm	L590 x W400 x H350	1/6
110000-01	10,000ml	11,980ml	PET	70mm HDPE	395 x 212 x 212 mm	L458 x W248 x H458	1/2
120000-01	20,000ml	23,120ml	PET	70mm HDPE	500 x 256 x 256 mm	L590 x W330 x H570	1/2

PC PHARMATAINERS™

PET PHARMATAINERS™

CELLON



Cellon SA • ZAE Robert Steichen • 16, rue Héierchen • L-4940 Bascharage • G-D Luxembourg

E-mail: sales@cellon.lu • Tel: (352) 26 33 73-1 • Fax: (352) 31 10 52 • www.cellon.lu

PharmaTainer™ Stability vial

PharmaTainer™ Stability Vials for Drug Substance Testing

10mL PharmaTainer™ Stability Vials are now available to enable customers to evaluate and monitor drug substance storage. Small stability containers are beneficial in early stages of the drug development cycle when materials are only available in small quantities. Later in the product life cycle using a small stability container minimizes the consumption of valuable drug substance in testing.



PharmaTainer™ stability vials are manufactured from the same materials* used in larger PharmaTainer™ bioprocess storage containers. The 29 mm HDPE closures feature the same double-seal system found through-out the PharmaTainer™ product range.

Vials are available in both Polycarbonate and PET. Brim capacity of the vial is 12 ml. The vials come packed 49 in a high density (30g/l) foam rack which has a tight closed cell structure, ensuring low particle emission and excellent shock absorbing capabilities. Each rack of 49 vials is provided in a poly vacuum pack and then over-packed in a heat-sealed sleeve. Each carton contains 5 double bagged racks of vials for a total count of 245 vials per carton.

Cap torque chucks are also available to enable closures to be applied with a known and consistent torque force.

Cat. No.	Description	Units / pack
100S10-49	10ml PET Stability Vial Sterile SAL ¹⁰⁻⁶ 5 x trays of 49 vial	245
200S10-49	10ml PC Stability Vial Sterile SAL ¹⁰⁻⁶ 5 x trays of 49 vial	245
2595-PC28	Polycarbonate chuck for 28mm cap	1

- PC Stability vials are manufactured from HPS6-1H1125, the injection molding version of HPS9 -1H1125, which is primarily used for injection stretch blow molding. HPS9 -1H1125 has longer polymer chain lengths than HPS6-1H1125



PharmaTainer – Product Specification Sheet

125ml PET Pharmatainer (PharmaPack)	Catalogue number 100125-05
--	---------------------------------------

Bottle part number	100125-single	USP Class VI /EP	ADCF	DMF No.
Bottle material	Cellon resin code 001	Yes	Yes	15205
Nominal volume	125ml	Tolerance +/- 1.2mm	Accuracy +/-2%	Shape (footprint) Square
Brim capacity	196ml			
Bottle dimensions w/o cap	H95 x W58.8 x D58.8mm			
Bottle weight w/o cap	50.1g			
Bottle thread O.D.	44mm	+/-0.3mm		
Bottle neck I.D.	37mm	+/-0.25mm		
Graduations	25ml – 125ml	25ml intervals		Endotoxin
Sterility	C60 γ irradiated	SAL 10-6		No detectable Endotoxin Certified by Lot
Bottle decoration	Graduation scale	Lot number	Expiration date	Data matrix
Bottle colour	Clear			
Traceability	Lot number	Data matrix	Serial number	

Closure part number	300048C-01	USP Class VI / EP	ADCF	DMF No.
Closure material	Cellon resin code 003	Yes	Yes	1646
		Tolerance		
Closure weight	12 g	+/- 3%		
Closure dimensions	H 25mm O.D. 49mm	+/- 0.3mm		
Closure colour	Natural			

Packaging materials	Carton	Level 3 Carton liner	Level 2	Level 1 Sterile barrier
	4mm single corrugate, top and base protection sheet	50 μ LDPE monolayer film tape sealed bag	100 μ LDPE monolayer film Heat sealed bag	120 μ PE/PA/PE multilayer film vacuum bag heat sealed

Carton dimensions	Carton weight	Units per carton	Units per sterile barrier
L 620, W 340, H 270 mm	7.86kg	100 units	5 (PharmaPack 5)

	Dimensions	Weight (inc.pallet)	Cartons per pallet	Units per pallet
Euro pallet	1200x 800x2190mm	207kg	24	2400
Industry pallet	1200x1000x1860mm	248kg	30	3000

VERSION NO	003	28/02/2012
-------------------	------------	-------------------

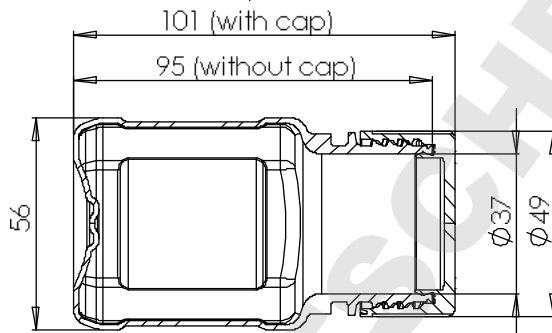
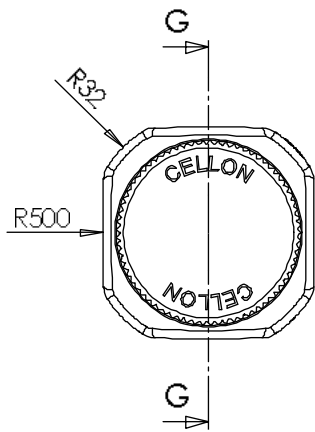

SECTION G-G

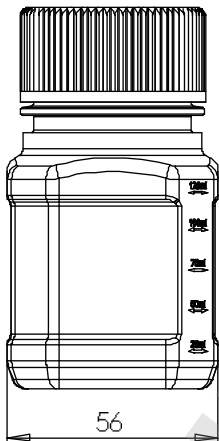
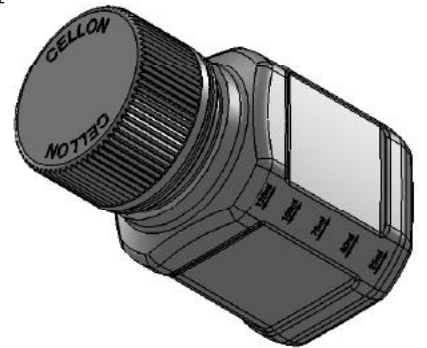

item	polymer
bottle	Polycarbonate (PC) or Polyethylenterephthlate (PET)
cap	High Density Polyethylene

Application range	Perm	Tolerance	Surface	Scale	1:1	A3	Quantity	1
				Material	*1, *C			
				Raw part #				
				Model #				
	Editor 2D	Date	Name	Designation				
	Check			bottle 125ml v4				
	Editor 3D	27/04/2011	Duchene					
				Drawing number				
				CELLON S.A.				
Resp	Modification	Date	Name	Origin	Sheet			1/1
					1 Sh			

the information contained in this drawing is the sole property of CELLON S.A. Any reproduction or use in whole or in part without the written permission of CELLON S.A. is prohibited.

DOMINIQUE DUCHENE SAS

DOMINIQUE DUCHENE SAS

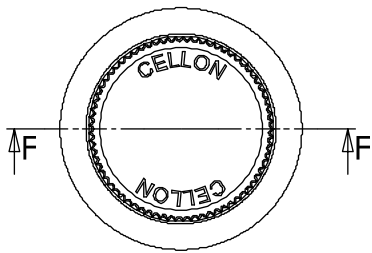

1st seal
activated by
bending force

detail G
Scale 10 : 1

2nd seal
activated by
torque

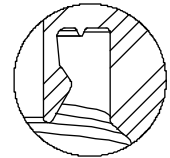
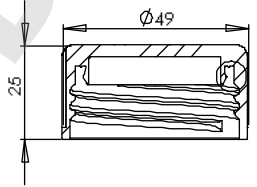
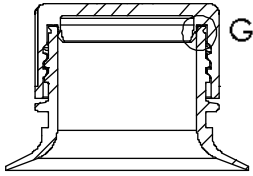
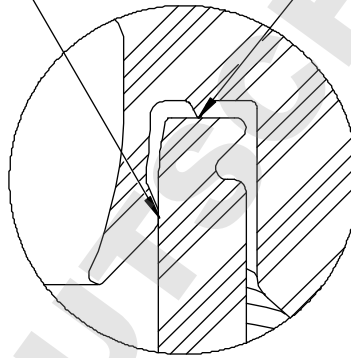

detail I
Scale 5 : 1
sealing
mechanism



Le présent document est
la propriété de
CELLON S.A. Any
reproduction or use in whole
without the written permission of
CELLON S.A. is prohibited

Form and General tolerance	
DIN ISO 2768-	H
Roughness: DIN ISO 1302 -	
$\sqrt{R_{\text{a}}}$ ($\sqrt{R_{\text{a}}}$)	
Edges: DIN 6784	
$\begin{matrix} D \\ \swarrow \searrow \\ \text{0.2} \\ \swarrow \searrow \\ D \end{matrix}$	
Dimension without Tol:	
0.5 3 6 30 120 400	...
...3 ...6 ...30 ...120 ...400 ...1000	...
±0.1	±0.15
±0.2	±0.3
±0.3	±0.5
±0.5	±0.8
Fillet - Chamfer:	
±0.1	±0.2
±0.5	±1
±2	±3
Squarness, Dim of the shorter side:	
10 50 120 400	...
bis 10 ...50 ...120 ...400
±1°	±30'
±20'	±10'
±5'	±5'

item	polymer
cap	High Density Polyethylene
Application range	Perm Tolerance Surface
	Scale 1:1 A3 Quantity 1
	Material: HDPE (H+M+ZD)
	Raw part #
	Model #
	Designation
	Cap 1
	configuration: Default
	Drawing number
	CELLON S.A.
Resp	Modification
Date	Name
Origin	Sheet 1/1
	1 Sh

Certificate of Compliance

Catalogue Number	100125-05
Description	125 ml PET PharmaTainer™
Lot number	
Irradiation Order Number	
Irradiation Date	
Irradiation Dose Range Applied	Min dose 25kGy – Max dose 40kGy
Sterility Status	Sterile SAL 10 ⁻⁶
Product Expiration Date	

Raw material information

Component description	Resin	USP Class VI	ADCF*	Resin approved for health care /medical use	DMF No.
Bottle	PET	Yes	Yes	Yes	15205
Cap	HDPE	Yes	Yes	Yes	1646

*Animal Derived Component Free

Product information

Cellon has the following documentation on file:

Documentation that this lot conforms to our tolerances for configuration and quality.

Certification that the components used in the manufacture of this product have passed USP Class VI testing,

Sterilization: Certification that a VD_{max}²⁵ sterilization validation study to ISO11137 -2:2007, using method VD_{max}²⁵ "Sterilization of health care products – Radiation - part 2: Establishing the sterilization dose" has been successfully completed for PharmaTainer™, product family to verify that a 25kGy irradiation dose achieves a Sterility assurance level (SAL) of 10⁻⁶. Sterility assurance is maintained by quarterly dose audit studies. Product is irradiated by Gamma (γ) irradiation (Cobalt 60 source)

Endotoxin: Representative samples of finished product have been tested by an independent laboratory and determined to contain no detectable endotoxin. Testing is based on a validated assay method using a 5% rinse volume and detection limit of 0.001 EU/ml and complies with current USP and EP Bacterial Endotoxin tests (BET) methodologies. The endotoxin test is carried out on a lot by lot basis.

Particulate: Representative samples of product have been tested using liquid particle counter technology in a validated testing procedure and have found to meet the criteria for particulates USP <788 >, EP2.9.19 and JP 14th edition part 1 section 24. Particulate testing is carried out on a lot by lot basis.

This is Cellon's sole warranty with respect to the product. Cellon makes no warranty express or implied as to the merchantability of the product or its fitness for any specific purpose, unless the user is supplied with a separate written warranty for a particular use or purpose. This product is not approved for implant into the human body. No responsibility is accepted for alteration, abuse or misuse of the product. Cellon's sole liability for breach of warranty is limited to refund of purchase price or replacement of any product found to be defective.

Certified by: _____
Managing Director

Date: _____
(DD.MM.YYYY)

CELLON
ZAE Robert Steichen
16 rue Héierchen
L-4940 Bascharage
Luxembourg

Tel.: (352) 26 33 73
Fax: (352) 31 10 52
E-mail: sales@cellon.lu
Web Site: www.cellon.lu