



Defender[®] 5000 Indicators Instruction Manual



TD52XW



TD52P

TABLE OF CONTENTS

1. INTRODUCTION	5
1.1 Safety Precautions	5
1.1.1 Relay Option Safety Precautions	5
1.2 Overview of Parts and Controls	6
1.3 Control Functions.....	9
2. INSTALLATION	10
2.1 Unpacking	10
2.2 External Connections.....	10
2.2.1 Scale Base with Connector.....	10
2.2.2 RS232 interface Cable to TD52P	10
2.2.3 AC Power to TD52P	10
2.2.4 AC Power to TD52XW.....	10
2.2.5 Battery Power.....	10
2.3 Internal Connections.....	11
2.3.1 Opening the Housing	11
2.3.2 Scale Base Without Connector	11
2.3.3 RS232 Interface Cable to TD52XW	13
2.3.4 MICRO SD Card Installation.....	14
2.4 TD52XW Rear Housing Orientation	14
2.5 Mounting Bracket	14
3. SETTINGS	15
3.1 Menu Structure	15
3.2 Menu Navigation.....	18
3.3 Calibration Menu	18
3.3.1 Zero Calibration	18
3.3.2 Span Calibration	19
3.3.3 Linearity Calibration	20
3.3.4 GEO Adjustment	21
3.4 Setup Menu	22
3.4.1 Capacity Unit.....	22
3.4.2 Range	22
3.4.3 Capacity	22
3.4.4 Graduation.....	23
3.4.5 Language	23
3.4.6 Power On Zero	23
3.4.7 Power On Unit	23
3.4.8 Key Beep.....	23

3.4.9 Transaction Counter.....	24
3.4.10 I/O Type.....	24
3.4.11 Reset.....	24
3.5 Readout Menu.....	24
3.5.1 Stability.....	24
3.5.2 Zero Range.....	24
3.5.3 Filter Level.....	25
3.5.4 Auto Zero Tracking.....	25
3.5.5 Auto Dim.....	25
3.5.6 ScreenSaver.....	25
3.5.7 Auto Off.....	25
3.5.8 Adjust Contrast.....	25
3.5.9 Reset.....	25
3.6 Discrete I/O.....	26
3.7 Weighing Unit.....	28
3.7.1 Gram (g).....	28
3.7.2 Kilogram (kg).....	28
3.7.3 Pound (lb).....	28
3.7.4 Ounce (oz).....	28
3.7.5 Pound: Ounce (lb: oz).....	28
3.7.6 Tonne (Metric Tonne).....	28
3.7.7 Ton (Short Ton).....	28
3.7.8 Custom Unit (c).....	28
3.8 GLP/GMP Menu.....	29
3.8.1 Date Format.....	29
3.8.2 Date.....	29
3.8.3 Time Format.....	29
3.8.4 Time.....	29
3.8.5 Project ID.....	29
3.8.6 Scale ID.....	29
3.8.6 Reset.....	30
3.9 Communication.....	30
3.9.1 RS232/2nd RS232 Configuration.....	30
3.9.2 Print Setup of RS232/2nd RS232.....	31
3.9.3 RS485 Configuration.....	34
3.9.4 Ethernet Configuration.....	34
3.9.5 Wifi Configuration.....	34
3.9.6 Bluetooth Configuration.....	34

3.9.7 Analog Configuration	34
3.10 Maintenance Configuration	34
3.11 Lock Key Configuration	34
4. OPERATION	35
4.1 Weighing	35
4.1.1 Application Setup	35
4.1.2 Auto Tare	35
4.1.3 Accumulation	36
4.1.4 ID Input	37
4.1.5 Input/Output (I/O) Setup	37
4.2 Counting	38
4.2.1 Set the Average Piece Weight (APW)	38
4.2.2 Application Setup	39
4.2.3 Accumulation	40
4.2.4 Input/Output (I/O) Setup	40
4.3 Check	41
4.3.1 Check Weighing (default)	41
4.3.2 Check Counting	42
4.3.3 Application Setup	43
4.3.4 Input/Output (I/O) Setup	44
4.4 Percent Weighing	44
4.4.1 Establishing a Reference Weight	45
4.4.2 Application Setup	45
4.4.3 Input/Output (I/O) Setup	46
4.5 Dynamic Weighing	47
4.5.1 Application Setup	47
4.5.2 Average Time Setup	49
4.5.3 Input/Output (I/O) Setup	50
4.5 Filling	51
4.5.1 Establishing target weights	51
4.5.2 Application Setup	51
4.5.3 Input/Output (I/O) Setup	52
5. SERIAL COMMUNICATION	54
5.1 Interface Command	54
5.2 RS232 Interface	54
5.3 Connecting to a Computer	55
5.4 Connecting to a Serial Printer	55
5.5 Printouts	55

5.6 Printout Examples	56
6. MICRO SD CARD/USB	57
6.1 Library	57
6.2 User	60
6.3 Alibi	63
6.4 Editable	64
7. LEGAL FOR TRADE	65
7.1 Settings	65
7.2 Verification	65
7.3 Sealing	65
8. MAINTENANCE.....	66
8.1 Model T52P Cleaning	66
8.2 Model TD52XW Cleaning	66
8.3 Troubleshooting	66
8.4 Service Information	67
9. TECHNICAL DATA	67
9.1 Specifications	67
9.2 Accessories and Options	69
9.3 Drawings and Dimensions	70
9.4 Table of Geo Values	71
10. COMPLIANCE	72
11. APPENDICES.....	74
11.1 Appendix A	74
11.2 Appendix B	76

1. INTRODUCTION

This manual contains installation, operation and maintenance instructions for the TD52P and TD52XW Indicators. Please read this manual completely before installation and operation.

1.1 Safety Precautions



For safe and dependable operation of this equipment, please comply with the following safety precautions:

- Verify that the input voltage range printed on the data label matches the local AC power to be used.
- Make sure that the power cord does not pose a potential obstacle or tripping hazard.
- Use only approved accessories and peripherals.
- Operate the equipment only under ambient conditions specified in these instructions.
- Disconnect the equipment from the power supply when cleaning.
- Do not operate the equipment in hazardous or unstable environments.
- Do not immerse the equipment in water or other liquids.
- Service should only be performed by authorized personnel.
- The TD52XW is supplied with a grounded power cable. Use only with a compatible grounded power outlet.

1.1.1 Relay Option Safety Precautions

This equipment may have an optional Discrete I/O board installed. This option allows external devices to be controlled by the Indicator.



CAUTION: ELECTRICAL SHOCK HAZARD. REMOVE ALL POWER CONNECTIONS TO THE INDICATOR BEFORE SERVICING OR MAKING INTERNAL CONNECTIONS. THE HOUSING SHOULD ONLY BE OPENED BY AUTHORIZED AND QUALIFIED PERSONNEL, SUCH AS AN ELECTRICAL TECHNICIAN.

Before making connections to the Relay terminals, remove power from the system. If the system contains an optional rechargeable battery system, be sure that the **ON/CLR Off** button is used to fully turn off the system after removing the AC power plug.

More detailed installation instructions are included with the Discrete I/O kit at the time of purchase.

1.2 Overview of Parts and Controls

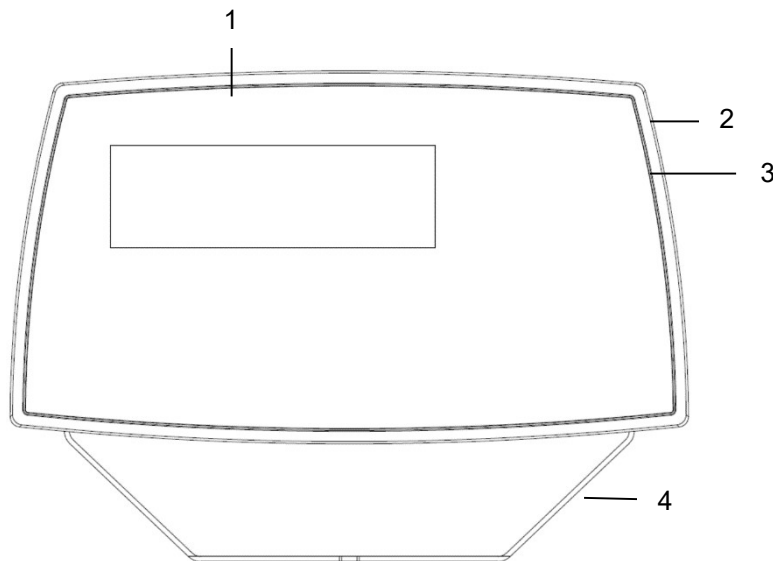

TABLE 1-1 TD52P PARTS

Item	Description
1	Data Label
2	Front Housing
3	Control Panel
4	Mounting Bracket
5	Screws (4)
6	Adjusting Knobs (2)
7	Security Screw
8	Accessory Cover
9	Rear Housing
10	Power Connector
11	RS232 Connector
12	Load Cell Connector

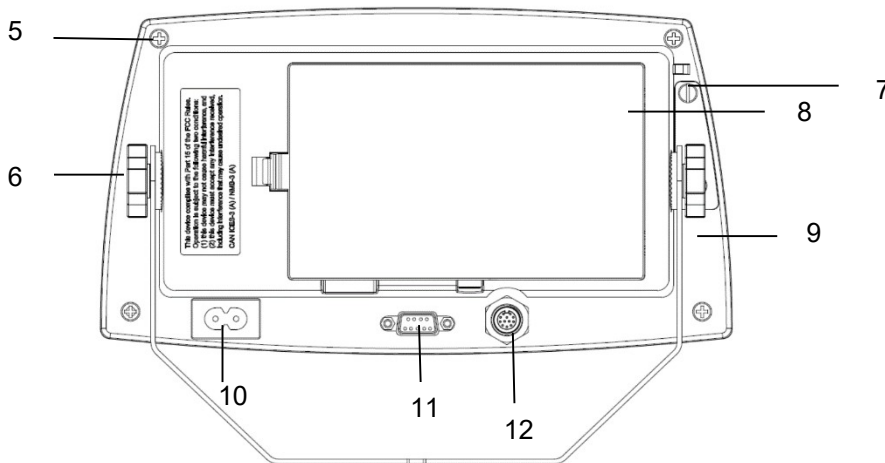

Figure 1-1 TD52P Indicator

1.2 Overview of Parts and Controls (Cont.)

TABLE 1-2 TD52XW PARTS

Item	Description
1	Control Panel
2	Front Housing
3	Screws (6)
4	Adjusting knobs (2)
5	Rear Housing
6	Mounting Bracket
7	Load Cell Connector
8	Strain Relief for Option
9	Power Cord
10	Strain Relief for Option

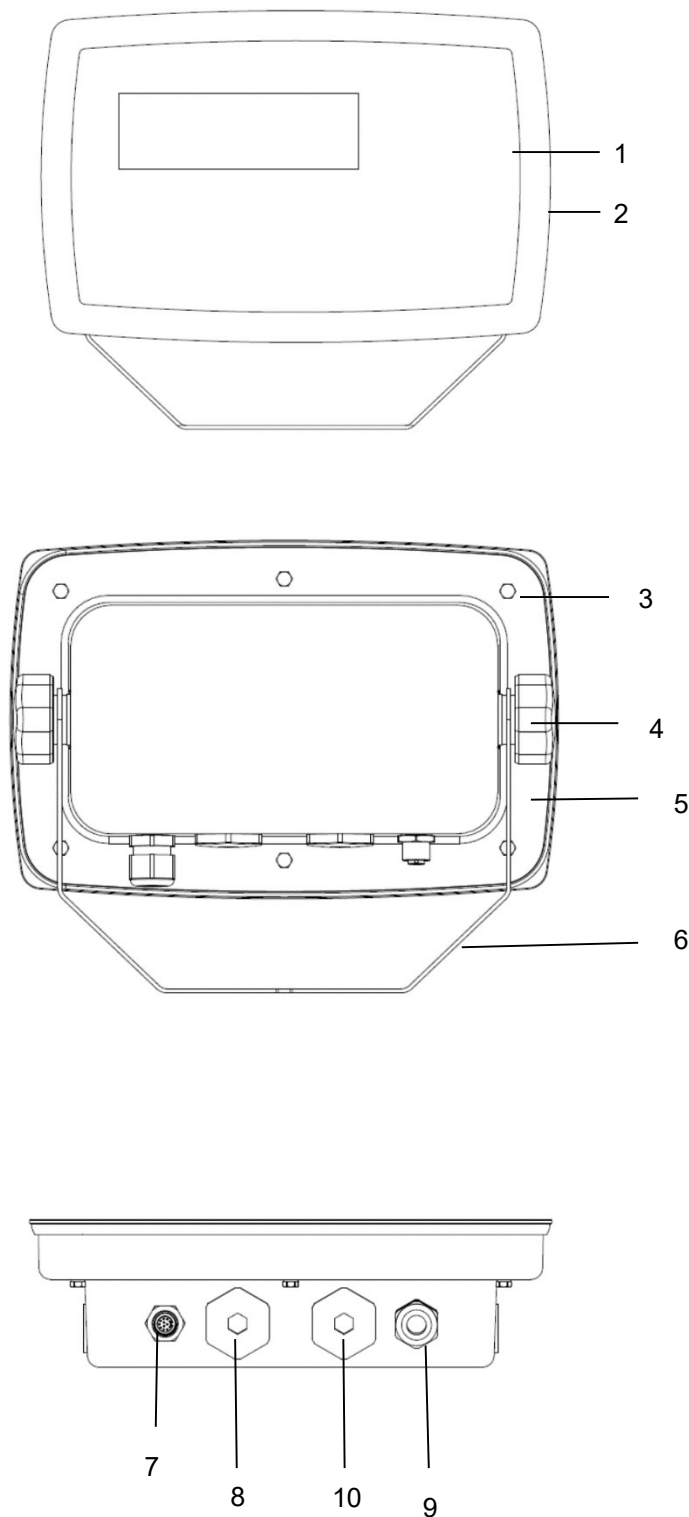

Figure 1-2 TD52XW Indicator

1.2 Overview of Parts and Controls (Cont.)

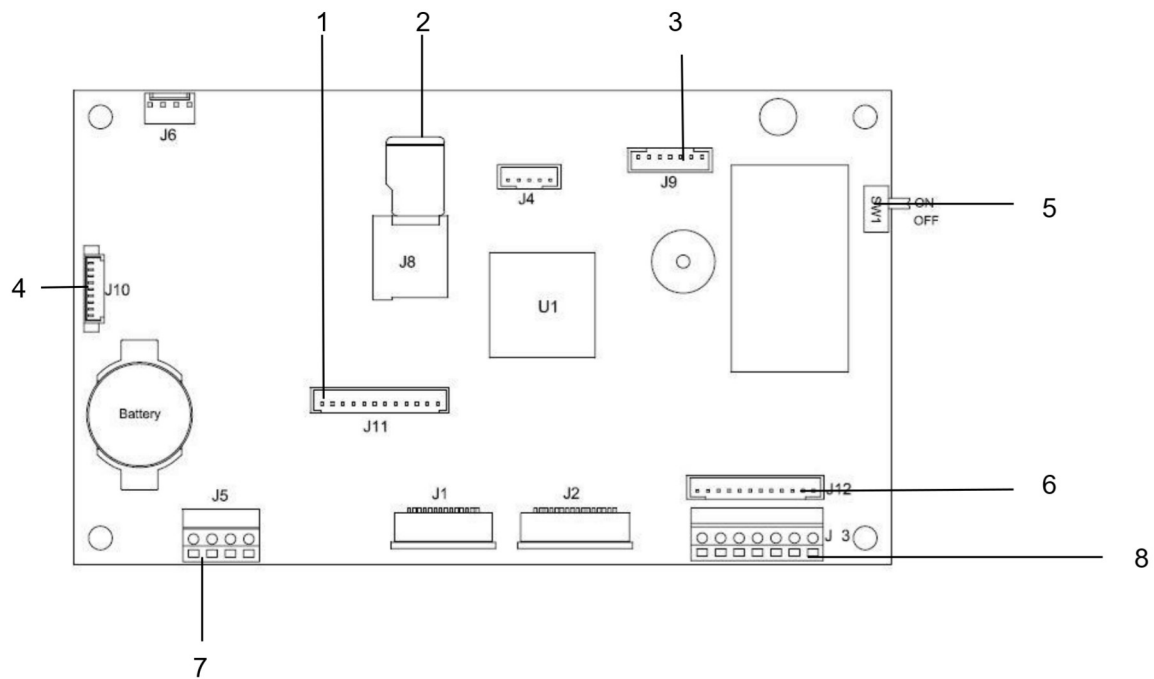
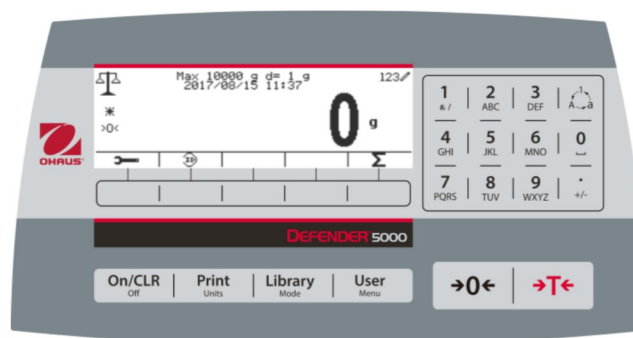

















Figure 1-3 Main PC Board

TABLE 1-3 MAIN PC BOARD

Item	Description
1	IO/Analog/RS232-RS485-USB Device connector (J11)
2	Micro-SD Card slot (J8)
3	Rechargeable Battery Pack connector (J9)
4	USB Host/Ethernet connector (J4)
5	Security Switch connector (SW1)
6	Load Cell connector (J12)
7	RS232 connector (J5)
8	Load Cell Terminal Block (J3)

1.3 Control Functions



Button	Action
	Short press: If the terminal is Off, power on the terminal; if the terminal is On, clear the data input. Long press: Power off the terminal.
	Short press: Send the current display value to RS232 port or Option when properly enabled. Long press: Change the current weighing unit. Press and hold the key to scroll through the list of enabled units. Release the key to switch to the unit selected.
	Short press: Press the key to enter the Library. Long press: Press and hold this key to change weighing modes. Press and hold the key to scroll through all weighing modes. Release the key to switch to the mode selected.
	Short press: Press the key to enter user profile. Long press: Press the key to enter user menu.
	The 5 Softkeys correspond to several icons at the bottom of the display area. These icons indicate for each Softkey functions specifically available for configuration and operation of the mode.
	  <p>To enter '2'-'9', press the numeric button in the mode of numeric input.</p>
	 <p>To Enter 'A', press  2 times in the mode of uppercase input. To enter 'z', press  5 times in the mode of lowercase input.</p>
	 <p>To enter '1', press the button in the mode of numeric input. To enter '#', '/', press the button in the mode of uppercase input. To enter '@', '_', '&', '!', '?', '*', or '^', press the button in the mode of lowercase input.</p>
	 <p>Switch between three input modes – numeric, lowercase and uppercase input.</p>
	 <p>To enter '.', press the button in the mode of numeric input. To enter '+' or '-', press the button in the mode of uppercase or lowercase input.</p>
	Short press: When the load on the pan is within the zero range, press this key to set the display to zero.
	Short press: When a container is on the pan, press this key to store the weight of the container as the tare value. Short press: Enter the known weight of a container using the numeric keypad, and then press this key to establish the preset tare value. Short press: When a tare has been entered, empty the pan and press this key to clear the tare value. Long press: If a preset tare has been entered, press this key to view the preset tare value.

2. INSTALLATION

2.1 Unpacking

Unpack the following items:

- TD52P or TD52XW Indicator
- AC Power Cord (for TD52P only)
- Mounting Bracket
- Knobs (2)
- Drilled Sealing Screws (for TD52XW only)
- Quick installation Guide
- Warranty Card
- Ferrite core

2.2 External Connections

2.2.1 Scale Base with Connector

OHAUS bases with a connector can be attached to the external load cell connector (Figure 1-1, item 12). To make the connection, plug the base connector onto the external load cell connector. Then rotate the base connector's locking ring clockwise. Refer to section 2.3.2 for bases without a connector.

2.2.2 RS232 interface Cable to TD52P

Connect the optional RS232 cable to the RS232 connector (Figure 1-1, item 11).

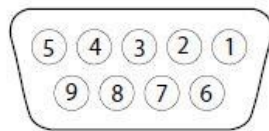

Figure 2-1 RS232 Pins

Pin	Connection
1	N/C
2	TXD
3	RXD
4	N/C
5	GND
6	N/C
7	CTS
8	RTS
9	N/C

2.2.3 AC Power to TD52P

Connect the AC power cord (supplied) to the power receptacle (Figure 1-1, item 10), then connect the AC plug to an electrical outlet.

2.2.4 AC Power to TD52XW

Connect the AC plug to a properly grounded electrical outlet.

2.2.5 Battery Power

The indicator can be operated on the rechargeable battery pack (optional) when AC power is not available. It will automatically switch to battery operation if there is power failure or the power cord is removed. The indicator can operate for up to 21 hours on battery power. During battery operation, the battery charge symbol indicates the battery status. The indicator will automatically turn-off when the batteries are fully discharged. Find detailed installation information in battery pack (P/N 30424405) operation manual.

	Battery 5 - 25 % remaining
	Battery 25 - 50 % remaining
	Battery 50 - 75 % remaining
	Battery 75 - 100 % remaining