



Defender[®] 5000 Indicators Instruction Manual



TD52XW



TD52P

TABLE OF CONTENTS

1. INTRODUCTION	5
1.1 Safety Precautions	5
1.1.1 Relay Option Safety Precautions	5
1.2 Overview of Parts and Controls	6
1.3 Control Functions.....	9
2. INSTALLATION	10
2.1 Unpacking	10
2.2 External Connections.....	10
2.2.1 Scale Base with Connector.....	10
2.2.2 RS232 interface Cable to TD52P	10
2.2.3 AC Power to TD52P	10
2.2.4 AC Power to TD52XW.....	10
2.2.5 Battery Power.....	10
2.3 Internal Connections.....	11
2.3.1 Opening the Housing	11
2.3.2 Scale Base Without Connector	11
2.3.3 RS232 Interface Cable to TD52XW	13
2.3.4 MICRO SD Card Installation.....	14
2.4 TD52XW Rear Housing Orientation	14
2.5 Mounting Bracket	14
3. SETTINGS	15
3.1 Menu Structure	15
3.2 Menu Navigation.....	18
3.3 Calibration Menu	18
3.3.1 Zero Calibration	18
3.3.2 Span Calibration	19
3.3.3 Linearity Calibration	20
3.3.4 GEO Adjustment	21
3.4 Setup Menu	22
3.4.1 Capacity Unit.....	22
3.4.2 Range	22
3.4.3 Capacity	22
3.4.4 Graduation.....	23
3.4.5 Language	23
3.4.6 Power On Zero	23
3.4.7 Power On Unit	23
3.4.8 Key Beep.....	23

3.4.9 Transaction Counter	24
3.4.10 I/O Type	24
3.4.11 Reset	24
3.5 Readout Menu	24
3.5.1 Stability	24
3.5.2 Zero Range	24
3.5.3 Filter Level	25
3.5.4 Auto Zero Tracking	25
3.5.5 Auto Dim	25
3.5.6 ScreenSaver	25
3.5.7 Auto Off	25
3.5.8 Adjust Contrast	25
3.5.9 Reset	25
3.6 Discrete I/O	26
3.7 Weighing Unit	28
3.7.1 Gram (g)	28
3.7.2 Kilogram (kg)	28
3.7.3 Pound (lb)	28
3.7.4 Ounce (oz)	28
3.7.5 Pound: Ounce (lb: oz)	28
3.7.6 Tonne (Metric Tonne)	28
3.7.7 Ton (Short Ton)	28
3.7.8 Custom Unit (c)	28
3.8 GLP/GMP Menu	29
3.8.1 Date Format	29
3.8.2 Date	29
3.8.3 Time Format	29
3.8.4 Time	29
3.8.5 Project ID	29
3.8.6 Scale ID	29
3.8.6 Reset	30
3.9 Communication	30
3.9.1 RS232/2nd RS232 Configuration	30
3.9.2 Print Setup of RS232/2nd RS232	31
3.9.3 RS485 Configuration	34
3.9.4 Ethernet Configuration	34
3.9.5 Wifi Configuration	34
3.9.6 Bluetooth Configuration	34

3.9.7 Analog Configuration	34
3.10 Maintenance Configuration	34
3.11 Lock Key Configuration	34
4. OPERATION	35
4.1 Weighing	35
4.1.1 Application Setup	35
4.1.2 Auto Tare	35
4.1.3 Accumulation	36
4.1.4 ID Input	37
4.1.5 Input/Output (I/O) Setup	37
4.2 Counting	38
4.2.1 Set the Average Piece Weight (APW)	38
4.2.2 Application Setup	39
4.2.3 Accumulation	40
4.2.4 Input/Output (I/O) Setup	40
4.3 Check	41
4.3.1 Check Weighing (default)	41
4.3.2 Check Counting	42
4.3.3 Application Setup	43
4.3.4 Input/Output (I/O) Setup	44
4.4 Percent Weighing	44
4.4.1 Establishing a Reference Weight	45
4.4.2 Application Setup	45
4.4.3 Input/Output (I/O) Setup	46
4.5 Dynamic Weighing	47
4.5.1 Application Setup	47
4.5.2 Average Time Setup	49
4.5.3 Input/Output (I/O) Setup	50
4.5 Filling	51
4.5.1 Establishing target weights	51
4.5.2 Application Setup	51
4.5.3 Input/Output (I/O) Setup	52
5. SERIAL COMMUNICATION	54
5.1 Interface Command	54
5.2 RS232 Interface	54
5.3 Connecting to a Computer	55
5.4 Connecting to a Serial Printer	55
5.5 Printouts	55

5.6 Printout Examples	56
6. MICRO SD CARD/USB	57
6.1 Library	57
6.2 User	60
6.3 Alibi	63
6.4 Editable	64
7. LEGAL FOR TRADE	65
7.1 Settings	65
7.2 Verification	65
7.3 Sealing	65
8. MAINTENANCE.....	66
8.1 Model T52P Cleaning	66
8.2 Model TD52XW Cleaning	66
8.3 Troubleshooting	66
8.4 Service Information	67
9. TECHNICAL DATA	67
9.1 Specifications	67
9.2 Accessories and Options	69
9.3 Drawings and Dimensions	70
9.4 Table of Geo Values	71
10. COMPLIANCE	72
11. APPENDICES.....	74
11.1 Appendix A	74
11.2 Appendix B	76

1. INTRODUCTION

This manual contains installation, operation and maintenance instructions for the TD52P and TD52XW Indicators. Please read this manual completely before installation and operation.

1.1 Safety Precautions



For safe and dependable operation of this equipment, please comply with the following safety precautions:

- Verify that the input voltage range printed on the data label matches the local AC power to be used.
- Make sure that the power cord does not pose a potential obstacle or tripping hazard.
- Use only approved accessories and peripherals.
- Operate the equipment only under ambient conditions specified in these instructions.
- Disconnect the equipment from the power supply when cleaning.
- Do not operate the equipment in hazardous or unstable environments.
- Do not immerse the equipment in water or other liquids.
- Service should only be performed by authorized personnel.
- The TD52XW is supplied with a grounded power cable. Use only with a compatible grounded power outlet.

1.1.1 Relay Option Safety Precautions

This equipment may have an optional Discrete I/O board installed. This option allows external devices to be controlled by the Indicator.



CAUTION: ELECTRICAL SHOCK HAZARD. REMOVE ALL POWER CONNECTIONS TO THE INDICATOR BEFORE SERVICING OR MAKING INTERNAL CONNECTIONS. THE HOUSING SHOULD ONLY BE OPENED BY AUTHORIZED AND QUALIFIED PERSONNEL, SUCH AS AN ELECTRICAL TECHNICIAN.

Before making connections to the Relay terminals, remove power from the system. If the system contains an optional rechargeable battery system, be sure that the **ON/CLR Off** button is used to fully turn off the system after removing the AC power plug.

More detailed installation instructions are included with the Discrete I/O kit at the time of purchase.

1.2 Overview of Parts and Controls

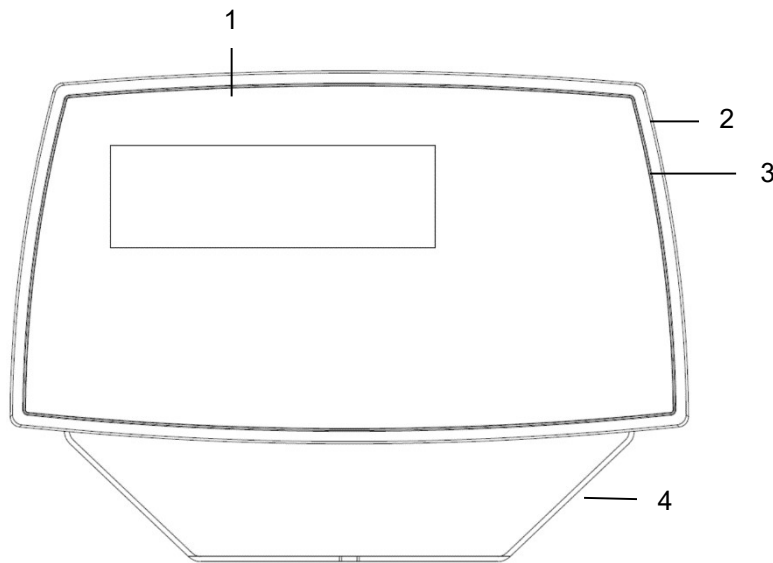

TABLE 1-1 TD52P PARTS

Item	Description
1	Data Label
2	Front Housing
3	Control Panel
4	Mounting Bracket
5	Screws (4)
6	Adjusting Knobs (2)
7	Security Screw
8	Accessory Cover
9	Rear Housing
10	Power Connector
11	RS232 Connector
12	Load Cell Connector

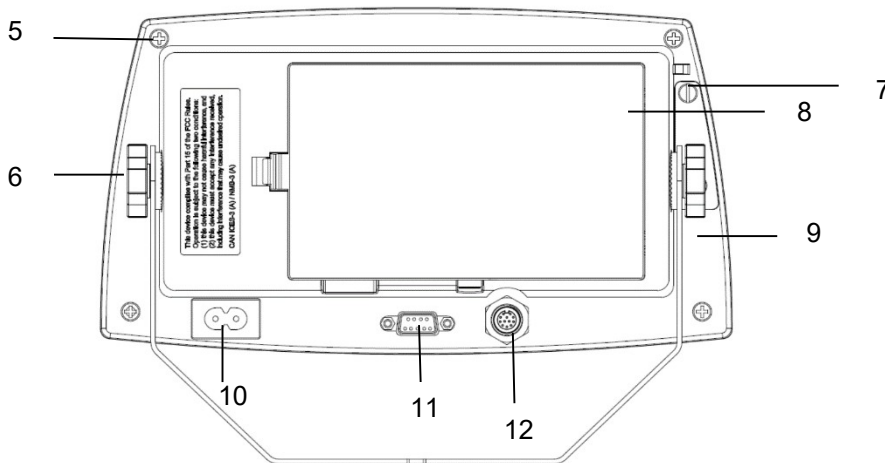

Figure 1-1 TD52P Indicator

1.2 Overview of Parts and Controls (Cont.)

TABLE 1-2 TD52XW PARTS

Item	Description
1	Control Panel
2	Front Housing
3	Screws (6)
4	Adjusting knobs (2)
5	Rear Housing
6	Mounting Bracket
7	Load Cell Connector
8	Strain Relief for Option
9	Power Cord
10	Strain Relief for Option

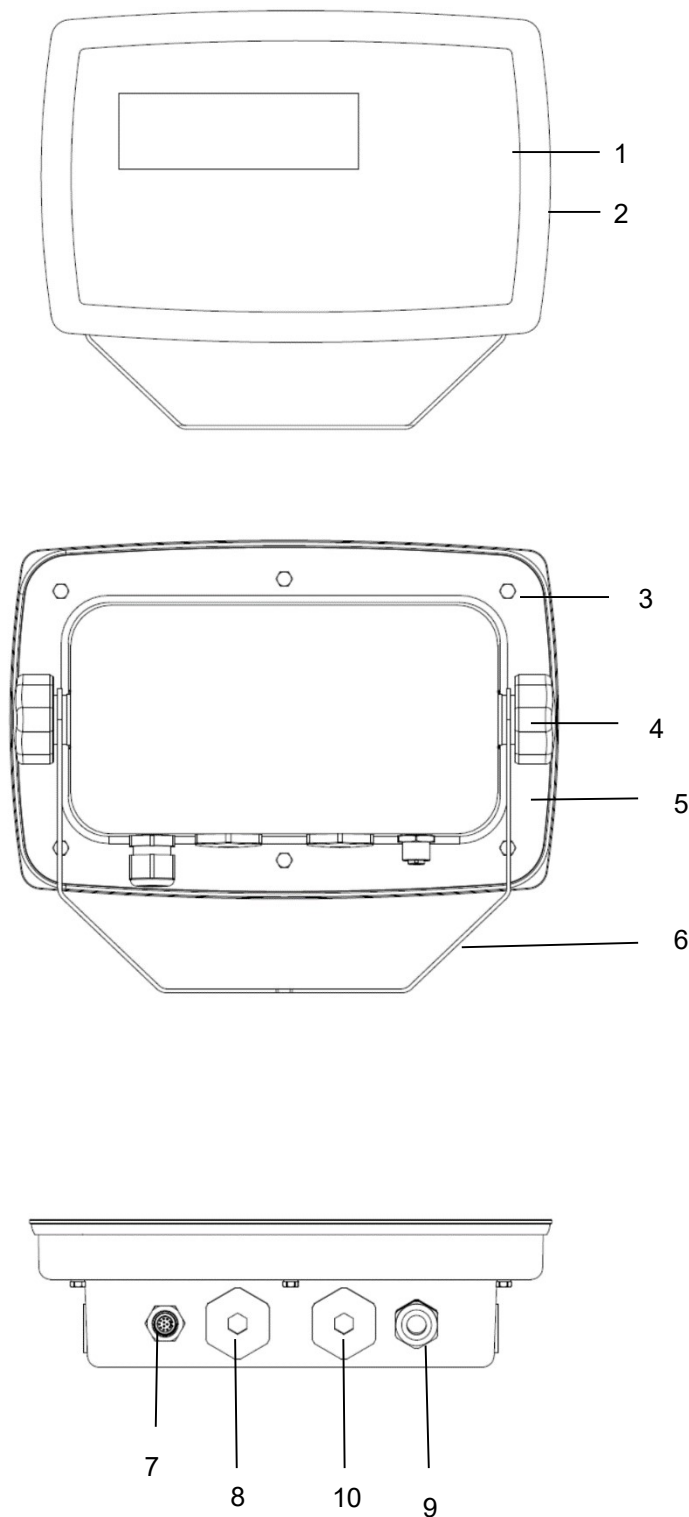

Figure 1-2 TD52XW Indicator

1.2 Overview of Parts and Controls (Cont.)

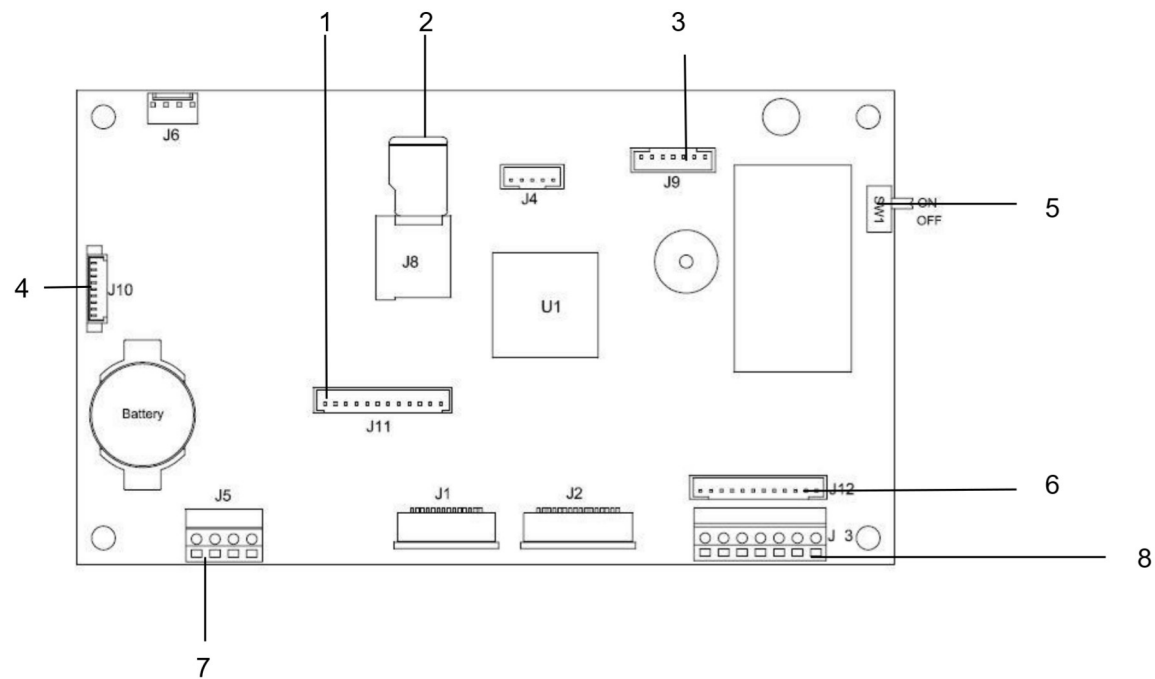
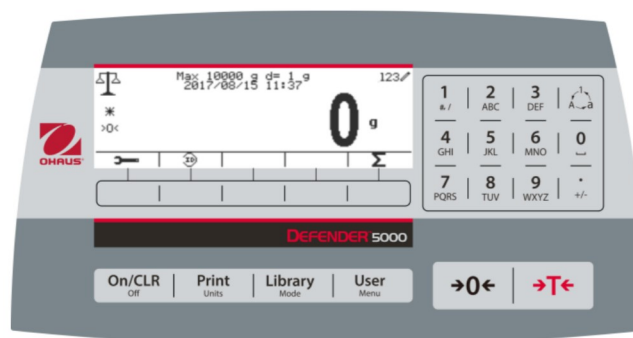

















Figure 1-3 Main PC Board

TABLE 1-3 MAIN PC BOARD

Item	Description
1	IO/Analog/RS232-RS485-USB Device connector (J11)
2	Micro-SD Card slot (J8)
3	Rechargeable Battery Pack connector (J9)
4	USB Host/Ethernet connector (J4)
5	Security Switch connector (SW1)
6	Load Cell connector (J12)
7	RS232 connector (J5)
8	Load Cell Terminal Block (J3)

1.3 Control Functions



Button	Action
	Short press: If the terminal is Off, power on the terminal; if the terminal is On, clear the data input. Long press: Power off the terminal.
	Short press: Send the current display value to RS232 port or Option when properly enabled. Long press: Change the current weighing unit. Press and hold the key to scroll through the list of enabled units. Release the key to switch to the unit selected.
	Short press: Press the key to enter the Library. Long press: Press and hold this key to change weighing modes. Press and hold the key to scroll through all weighing modes. Release the key to switch to the mode selected.
	Short press: Press the key to enter user profile. Long press: Press the key to enter user menu.
	The 5 Softkeys correspond to several icons at the bottom of the display area. These icons indicate for each Softkey functions specifically available for configuration and operation of the mode.
	  To enter '2'-'9', press the numeric button in the mode of numeric input.
	 To Enter 'A', press  2 times in the mode of uppercase input. To enter 'z', press  5 times in the mode of lowercase input.
	 To enter '1', press the button in the mode of numeric input. To enter '#', '/', press the button in the mode of uppercase input. To enter '@', '_', '&', '!', '?', '*', or '^', press the button in the mode of lowercase input.
	 Switch between three input modes – numeric, lowercase and uppercase input.
	 To enter '.', press the button in the mode of numeric input. To enter '+' or '-', press the button in the mode of uppercase or lowercase input.
	Short press: When the load on the pan is within the zero range, press this key to set the display to zero.
	Short press: When a container is on the pan, press this key to store the weight of the container as the tare value. Short press: Enter the known weight of a container using the numeric keypad, and then press this key to establish the preset tare value. Short press: When a tare has been entered, empty the pan and press this key to clear the tare value. Long press: If a preset tare has been entered, press this key to view the preset tare value.

2. INSTALLATION

2.1 Unpacking

Unpack the following items:

- TD52P or TD52XW Indicator
- AC Power Cord (for TD52P only)
- Mounting Bracket
- Knobs (2)
- Drilled Sealing Screws (for TD52XW only)
- Quick installation Guide
- Warranty Card
- Ferrite core

2.2 External Connections

2.2.1 Scale Base with Connector

OHAUS bases with a connector can be attached to the external load cell connector (Figure 1-1, item 12). To make the connection, plug the base connector onto the external load cell connector. Then rotate the base connector's locking ring clockwise. Refer to section 2.3.2 for bases without a connector.

2.2.2 RS232 interface Cable to TD52P

Connect the optional RS232 cable to the RS232 connector (Figure 1-1, item 11).

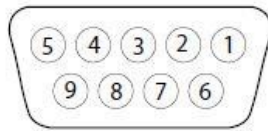

Figure 2-1 RS232 Pins

Pin	Connection
1	N/C
2	TXD
3	RXD
4	N/C
5	GND
6	N/C
7	CTS
8	RTS
9	N/C

2.2.3 AC Power to TD52P

Connect the AC power cord (supplied) to the power receptacle (Figure 1-1, item 10), then connect the AC plug to an electrical outlet.

2.2.4 AC Power to TD52XW

Connect the AC plug to a properly grounded electrical outlet.

2.2.5 Battery Power

The indicator can be operated on the rechargeable battery pack (optional) when AC power is not available. It will automatically switch to battery operation if there is power failure or the power cord is removed. The indicator can operate for up to 21 hours on battery power. During battery operation, the battery charge symbol indicates the battery status. The indicator will automatically turn-off when the batteries are fully discharged. Find detailed installation information in battery pack (P/N 30424405) operation manual.

	Battery 5 - 25 % remaining
	Battery 25 - 50 % remaining
	Battery 50 - 75 % remaining
	Battery 75 - 100 % remaining

2.3 Internal Connections

Some connections require the housing to be opened.

2.3.1 Opening the Housing



CAUTION: ELECTRICAL SHOCK HAZARD. REMOVE ALL POWER CONNECTIONS TO THE INDICATOR BEFORE SERVICING OR MAKING INTERNAL CONNECTIONS. THE HOUSING SHOULD ONLY BE OPENED BY AUTHORIZED AND QUALIFIED PERSONNEL, SUCH AS AN ELECTRICAL TECHNICIAN.

TD52P

Remove the four Phillips head screws from the rear housing.
Remove the front housing being careful not to disturb the internal connections.
Once all connections are made, reattach the front housing.

TD52XW

Remove the four hex head screws from the rear housing.
Open the housing by carefully pulling the front housing forward.
Once all connections are made, reattach the front housing.
The screws should be tightened to 2.5 N•m (20-25 in-lb) torque to ensure a watertight seal.

2.3.2 Scale Base Without Connector

For connecting bases (which do not have the Defender base quick connector) to a TD52P or TD52XW, a Load cell cable gland kit (P/N 30379716) is available as an accessory.

Removing the pre-installed Load Cell connector and wiring harness

Before doing the connections, remove the pre-installed Load Cell connector and wiring harness by following the steps below.

1. Open the housing by carefully pulling the front housing forward.
2. Unplug the white load cell connector from the main PCBA board (red circle).
3. Remove the metal terminal (Figure 1-1, item 12) connector from the rear housing. (green circle)

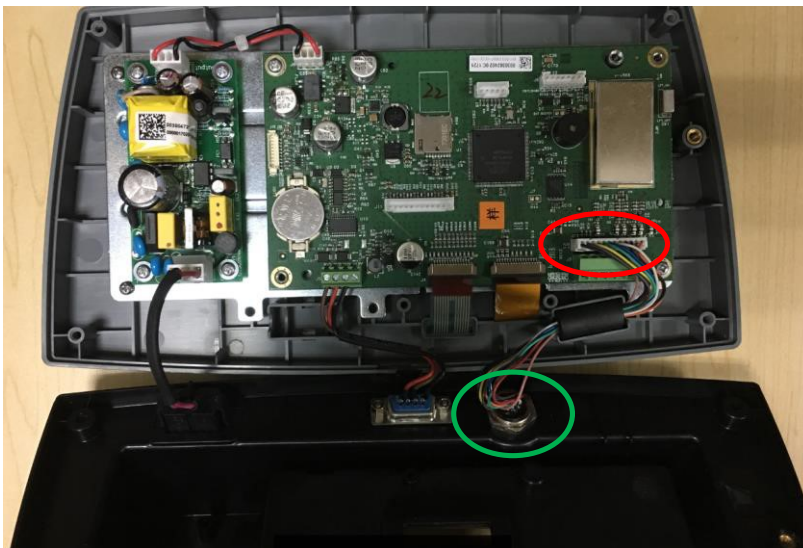

Installing Load Cell Cable and Connectors

In order to meet certain electrical noise emission limits and to protect the TD52P and TD52XW from external influences, it is necessary to install a ferrite core on the load cell cable connected to the terminal. The ferrite core is included with the terminal.

To install the ferrite, simply route the cable through the center of the core and then take one wrap around the outside of the core and route the cable through the center again. Either the complete cable or the individual wires can be wrapped through the ferrite. This should be done as close to the enclosure as possible. See Figure 2-2.



Figure 2-2

Main Board Wiring Connections

Once the TD52P and TD52XW enclosure is open, connections can be made to the terminal blocks on the main board, as shown in Figure 2-3.

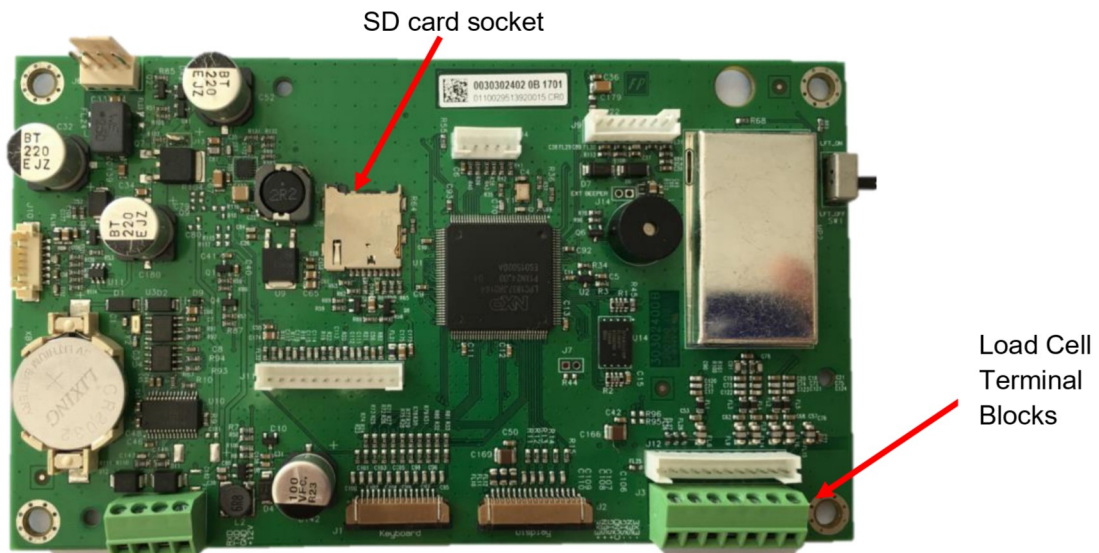
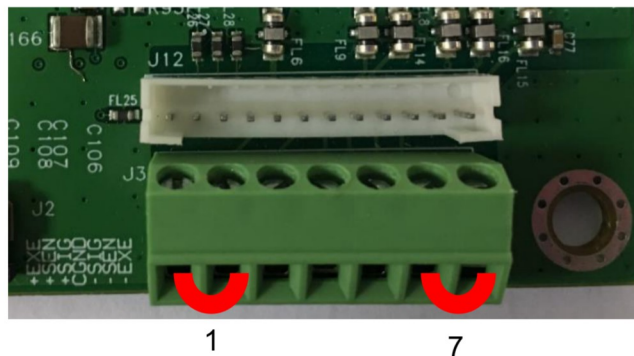

Figure 2-3

Jumper Connections

The TD52P and TD52XW indicators are designed to support both 2mV/V and 3mV/V load cells from the same circuitry. A load cell output rating selection jumper is not required.

Figure 2-4 shows the terminal definitions for the analog load cell terminal blocks. Note that when using four-wire load cells, jumpers must be placed between the +Excitation and +Sense terminals and between the Excitation and Sense terminals.



Pin	Connection
J3-1	+EXE
J3-2	+SEN
J3-3	+SIN
J3-4	GND
J3-5	-SIN
J3-6	-SEN
J3-7	-EXE

Figure 2-4 Jumper Connections

After wiring is completed, replace the indicator housing screws. Make sure the liquid-tight connector is properly tightened.



2.3.3 RS232 Interface Cable to TD52XW

Pass the optional RS232 cable through the strain relief and attach it to terminal block J5. Tighten the strain relief to maintain a watertight seal.

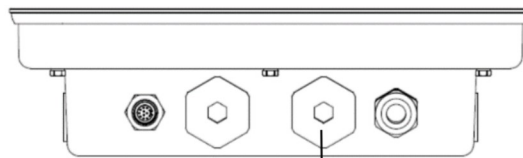

Strain Relief for Option

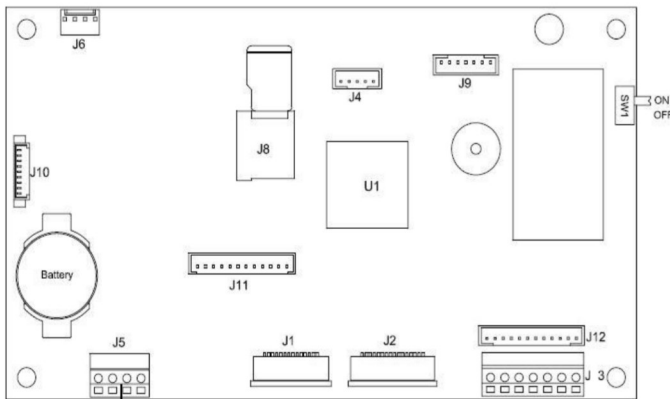

RS232 connector (J5)



2.3.4 MICRO SD Card Installation

The SD memory card can be used for additional storage in the Checkweighing and Counting applications. Figure 2-5 shows the installation of an SD card into the socket on the edge of the TD52P and TD52XW main boards.



Figure 2-5 Sliding an SD Card into the SD Socket (left); SD Card Installed (right)

2.4 TD52XW Rear Housing Orientation

The TD52XW is delivered in the wall mount orientation with the connections exiting below the display. The rear housing may be reversed so the connections exit above the display when the TD52XW is placed horizontally on a bench. To reverse the rear housing, remove the four Phillips head screws, carefully rotate the housing 180°, and reinstall the screws.

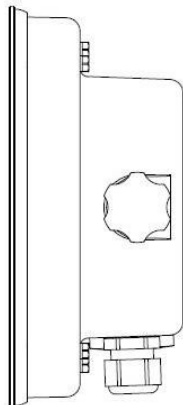

Figure 2-6 Wall Mount Configuration

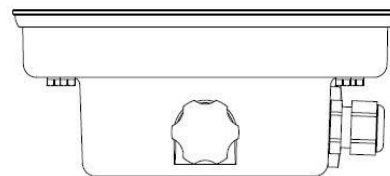

Figure 2-7 Bench Top Configuration

2.5 Mounting Bracket

Attach the bracket to a wall or table using fasteners (not supplied) that are appropriate for the type of mounting surface. The bracket will accommodate up to 6 mm (1/4") diameter screws. Locate the mounting holes as shown in Figure 2-8.

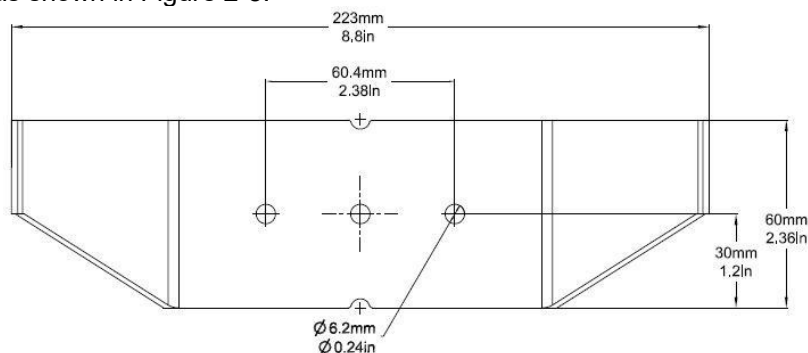

Figure 2-8 Mounting Bracket Dimensions

3. SETTINGS

3.1 Menu Structure

TABLE 3-1 MENU STRUCTURE

Calibration
Zero
Span
Linearity
GEO

Setup
Capacity Unit
Range
Capacity & Graduation
> 1 < Capacity
> 1 < Graduation
> 2 < Capacity
> 2 < Graduation
Language
Power On Zero
Power On Unit
Key Beep
Transaction Counter
Next Transaction
I/O Type
Reset

Read Out
Stability
Zero Range
Filter Level
Auto Zero Track
Auto Dim
Brightness
Screensaver
Auto Off
Adjust Contrast
Reset

Application Mode
Weighing
Counting
Check
Percent
Dynamic
Filling
Reset

Unit
Gram(g)
Kilogram(kg)
Pound(lb)
Ounce(oz)
Pound:Ounce (lb:oz)
Tonne(t)
Ton(ton)
Custom Unit
Unit Name
Factor
Exponent
LSD
Reset

GMP
Date Format
Date
Time Format
Time
Project ID
Scale ID
Reset

Communication		
RS232/ 2 nd RS232/USB Device*	Configuration	Baud Rate
		Parity
		Stop Bit
		Handshake
		Alt Print CMD
		Alt Tare CMD
		Alt Zero CMD
	Reset	
	Print Setup	Assignment
		Print Options
		Print Cal Data
		Select Template
		Edit Template
		Edit String
Reset		
RS485*	Configuration	Address
		Baud Rate
		Parity
		Stop Bit
		Handshake
		Alt Print CMD
		Alt Tare CMD
	Alt Zero CMD	
	Reset	
	Print Setup	Assignment
		Print Options
		Print Cal Data
		Select Template
		Edit Template
Edit String		
Reset		

Unit

GMP

Communication		
Ethernet*	Configuration	Host Name
		MAC Address
		Port
		Version
		DHCP
		IP Address
		Subnet Mask
		Gateway
		Primary DNS
		Secondary DNS
		Alt Print CMD
		Alt Tare CMD
		Alt Zero CMD
		Reset
Print Setup	Assignment	
	Print Options	
	Print Cal Data	
	Select Template	
	Edit Template	
	Edit String	
	Reset	
Wifi&Bluetooth*	Wifi	MAC Address
		Network
		Port
		DHCP
		IP Address
		Gateway
		DNS
		Subnet Mask
		Alternate Command
		Reset
	Bluetooth	Device name
	Print Setup	Assignment
		Print Options
		Print Cal Data
Select Template		
Edit Template		
Edit String		
Reset		
Analog*	Source	None , Displayed Weight, ABS- Displayed Weight, Gross Weight
	Output Type	4-20mA , 0-10V
	Zero Value	0(any valid value below the high limit)
	Full Scale Value	Desired source value, scale capacity
	Cal Output Zero	
	Cal Output Full	

SD Card/USB	
Library	
Memory	Mode
	Auto Print
	Save to
	Link to
User	User Profiles
	Supervisor Authority
	Password rule

Maintenance
Export Menu
Import Menu
Diagnosis
Format SD
Service Menu

Lock Key
Lock All Keys
Lock Off Key
Lock Zero Key
Lock Print Key
Lock Unit Key
Lock Soft Key
Lock Mode key
Lock Tare key
Lock Menu key
Reset

* Sub- menu for options will be active only when the specific board is installed.

Note: When you select Format SD in the maintenance menu, all the data in your SD card will be deleted.

The Bluetooth® word mark and logos are registered trademarks owned by Bluetooth SIG, Inc. and any use of such marks by OHAUS is under license.

3.2 Menu Navigation

To enter the Main Menu, press the button  from any application home screen.

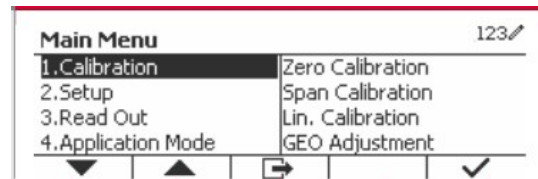



Changing Settings

To change a menu setting, navigate to that setting using the following steps:



1. Enter the Menu

From any Application screen, press the  button. The Main Menu List appears on the screen.

2. Select the Sub-menu

Scroll to the desired Sub-menu in the Main Menu List using the Softkey corresponding to the icon . Press the Softkey corresponding to the icon  to display the Sub-menu items.

3. Select the Sub-Menu Item

Scroll to the desired Sub-menu Item using the Softkey corresponding to the icon . Press the Softkey corresponding to the icon  to view the Sub-menu item's settings.

4. Select the Setting

Scroll to the desired Setting using the Softkey corresponding to the icon .

Press the Softkey corresponding to the icon  to select the setting.

Press the Softkey corresponding to the icon  to return to the previous screen.

Press the Softkey corresponding to the icon  to exit the menu and return to the last active Application mode.

3.3 Calibration Menu

The TD52 indicator offers three calibration methods: Zero Calibration, Span Calibration and Linearity Calibration.

NOTES:

1. Make sure that appropriate calibration masses are available before calibration.
2. Make sure that the scale base is level and stable during the entire calibration process.
3. Calibration is unavailable with LFT set to ON.
4. Allow the Indicator to warm up for approximately 5 minutes after stabilizing to room temperature.
5. To abort calibration, press the Softkey corresponding to the icon 'X' anytime during the calibration process.
6. When any selection within the GMP menu is enabled, calibration results are automatically printed.

3.3.1 Zero Calibration

Zero calibration uses one calibration point. The zero calibration point is established with no weight on the scale. Use this calibration method to adjust for a different dead load without affecting the span or linearity calibration.

Calibration procedures:

Long press the button  to enter the Main Menu. Press the Softkey corresponding to the icon  to enter the Calibration sub-menu.

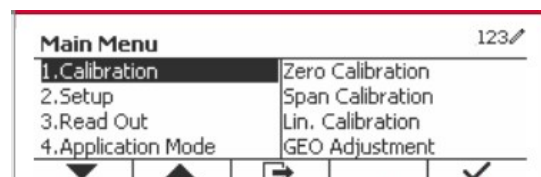

Zero Calibration is on the top of the list of Calibration by default. Just press the Softkey corresponding to the icon ✓ to initiate Zero Calibration.

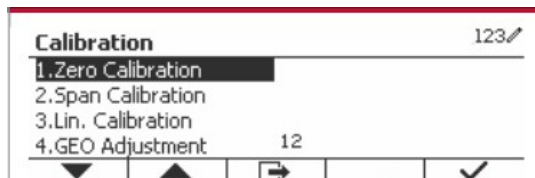

Clear the pan and then press the Softkey corresponding to the icon ✓.

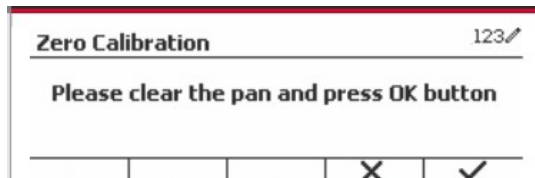

The message 'Completed' will be displayed on the screen.

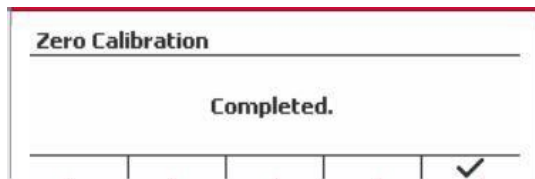

Exit Zero Calibration by pressing the Softkey corresponding to the icon ✓.

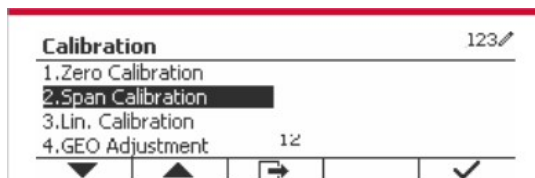

To return to the Main Menu, press the Softkey corresponding to the icon ✓.

3.3.2 Span Calibration

Span Calibration uses one point. The span calibration point is established with a calibration mass placed on the scale.

Note: Span Calibration should be performed after Zero Calibration.

Calibration procedures:

Long press the button  to enter the Main Menu.

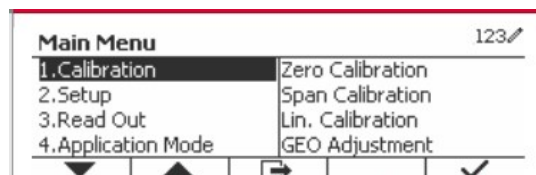

Press the Softkey corresponding to the icon ✓ to enter the Calibration sub-menu.

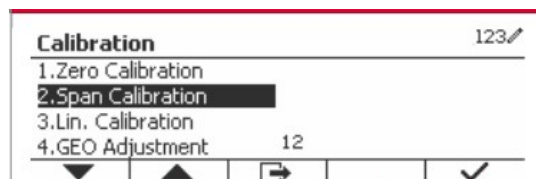

Scroll to Span Calibration using the Softkey corresponding to the icon ▼.

Press the Softkey corresponding to the icon ✓ to initiate Span Calibration.

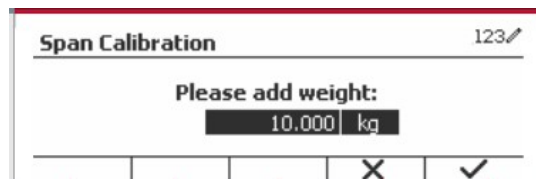

Place a calibration mass of the specified weight on the pan and press the Softkey corresponding to the icon ✓. To change to a different calibration point, input the value desired, and then place the corresponding weight on the pan for calibration.