



Defender® 2000 Series

Bench Scales & Indicator



Designed for Dependability and Durability at a Practical Price!

The OHAUS Defender 2000 Series of bench scales offers OHAUS' signature accuracy for commercial and industrial weighing applications at an unbeatable price. Depend on the OHAUS Defender 2000 Series when you need accuracy you can count on while maximizing your budget.

Standard Features Include:

- **Sturdy Industrial Design that Can Stand Up to the Rigors of Industrial Weighing**—The polished 430 stainless steel platform with painted carbon steel frame and aluminum alloy IP65 load cell provide strength and durability.
- **Easy-to-Read Red LED Display Can Be Viewed in Even the Dimmest Industrial Conditions**—Defender 2000's red LED indicator clearly displays results that can be seen in locations with less than optimal lighting.
- **Versatile Power Capabilities Provide Unrestricted Operation Wherever Your Weighing Needs Are**—An AC adapter and internal rechargeable lead acid battery provide options for powering your Defender 2000.

Defender[®] 2000 Series Bench Scales

Model	D24PE30FR	D24PE60FR	D24PE60FL	D24PE150FL	D24PE150FX	D24PE300FX	D24PE300FV	D24PE600FV
Certified Capacity × Readability	30 × 0.005 kg	60 × 0.01 kg	60 × 0.01 kg	150 × 0.02 kg	150 × 0.02 kg	300 × 0.05 kg	300 × 0.05 kg	600 × 0.1 kg
Recommended Disp. Resolution	1:6000	1:6000	1:6000	1:7500	1:7500	1:6000	1:6000	1:6000
Load Cell Protection	Aluminum alloy IP65							
Base Construction	Stainless Steel pan, painted carbon steel frame							
Platform Dimensions (W × D)	300 × 350		400 × 500		500 × 600		600 × 800	
Front View Dimensions (F1 × F2 × F3 × F4 × F5 × F6)	210 × 165 × 300 × 103 × 50 × 240 mm		210 × 165 × 400 × 115 × 50 × 315 mm		210 × 165 × 500 × 145 × 100 × 420 mm		210 × 165 × 600 × 170 × 100 × 522 mm	
Side View Dimensions (S1 × S2 × S3 × S4 × S5)	740 × 462 × 350 × 290 × 44 mm		940 × 612 × 500 × 435 × 44 mm		940 × 712 × 600 × 530 × 44 mm		1240 × 912 × 800 × 725 × 44 mm	
Column	500 mm		700 mm			1000 mm		
Leveling Component	Externally visible level bubble and adjustable leveling feet with locking nuts							
Safe Overload Capacity	125% of rated capacity							
Indicator Construction	ABS plastic housing							
Weighing Units	kg, g, lb							
Application Modes	Weighing, Parts Counting, Accumulation							
Display	6-digit, 7-segment red LED, 20 mm high digits							
Keyboard	4 function mechanical keys, raised, tactile							
Zero Range	2% or 100% of full scale capacity							
Tare Range	Full capacity by subtraction							
Stabilization Time	1 second							
Auto-Zero Tracking	Off, 0.5, 1 or 3 divisions							
Power	AC adapter with internal rechargeable lead acid battery							
Battery Life	80 hours continuous use with 12 hour recharge time							
Calibration	5 lb/kg to 100% of capacity, user selectable							
Interface	Optional RS232							
Operating Temperature Range	-10°C to 40°C							
Net Weight	11 kg		15 kg		26 kg		40 kg	
Shipping Weight	13 kg		17 kg		29 kg		45 kg	
Shipping Dimensions	745 × 420 × 185 mm		915 × 515 × 184 mm		1025 × 625 × 185 mm		1150 × 745 × 265 mm	

Other Standard Features and Equipment

Indicator with ABS plastic housing, red LED display, tactile mechanical keys, optional RS232C with manual/continuous/interval printing, hardware configuration lockout switch, internal lead-acid rechargeable battery and AC adapter. Software included for parts counting mode with selectable sample sizes and weighing totalization (Accumulation) functions. Selectable span calibration points, averaging level, auto-zero tracking and battery saving auto-off. Stainless steel pan with painted carbon steel tubular frame, non-slip rubber leveling feet with locking nuts, externally visible level bubble, aluminum alloy IP65 load cell, down-stops for overload protection

Compliance

- **Product Safety:** IEC/EN 61010-1
- **Electromagnetic Compatibility:** IEC/EN 61326-1 Class B, Basic environments

Dimensions

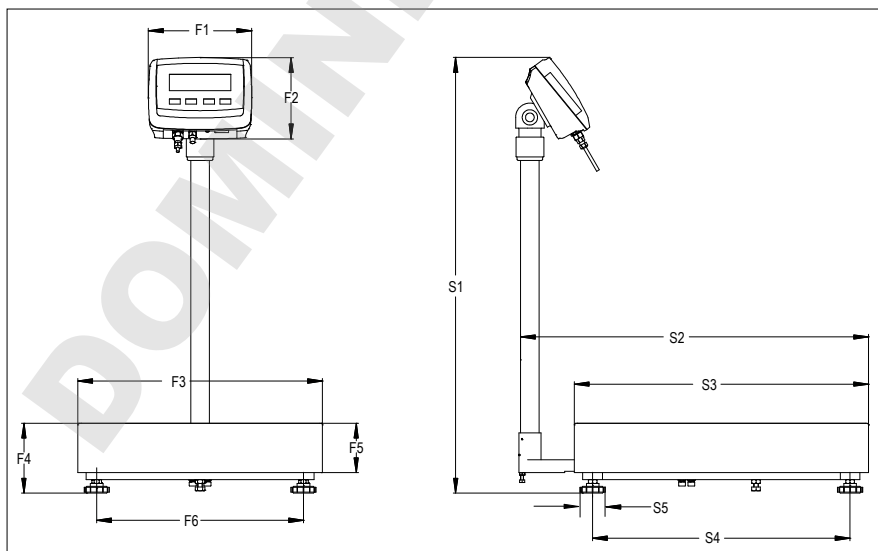

2000 Series T24PE Indicator



Designed for Dependability and Durability at a Practical Price!

The OHAUS Defender 2000 indicators offer OHAUS' signature accuracy for commercial and industrial weighing applications at an unbeatable price. Depend on the OHAUS Defender 2000 Series when you need accuracy you can count on while maximizing your budget.

Standard Features Include:

- **Enhanced Functionality Beyond Standard Weighing Provides Operation for Additional Applications**—In addition to standard weighing mode, this economical indicator also features parts counting and accumulation functions.
- **Easy-to-Read Red LED Display Can Be Viewed in Even the Dimmest Industrial Conditions**—Defender 2000 indicator's red LED indicator clearly displays results that can be seen in locations with less than optimal lighting.
- **Versatile Power Capabilities Provide Unrestricted Operation Wherever Your Weighing Needs Are**—An AC adapter and internal rechargeable lead acid battery provide options for powering your Defender 2000 indicator.

2000 Series T24PE Indicator

Model	T24PE
Capacity	Up to 20000 kg
Maximum Displayed Resolution	1:20000
Weighing Units	kg, g, lb
Application Modes	Weighing, Parts Counting, Accumulation
Construction	ABS plastic housing
Display	6-digit, 7-segment red LED, 20 mm high digits
Keyboard	4 function mechanical keys, raised, tactile
Load Cell Excitation Voltage	3 VDC
Load Cell Drive	Up to 4 × 350 ohm load cells
Load Cell Input Sensitivity	Up to 3 mV/V
Zero Range	2% or 100% of full scale capacity
Tare Range	Full capacity by subtraction
Stabilization Time	1 second
Auto-Zero Tracking	Off, 0.5, 1 or 3 divisions
Power	AC adapter with internal rechargeable lead acid battery
Battery Life	80 hours continuous use with 12 hour recharge time
Interface	Optional RS232
Operating Temperature Range	-10°C to 40°C
Housing dimensions (W × D × H)	210 × 168 × 80 mm
Net weight	1.4 kg
Shipping weight	2.4 kg
Shipping Dimensions (W × D × H)	272 × 235 × 175 mm

Other Standard Features and Equipment

ABS plastic housing, red LED display, tactile mechanical keys, optional RS232C with manual/continuous/interval printing, hardware configuration lockout switch, internal lead-acid rechargeable battery and AC adapter. Software included for parts counting mode with selectable sample sizes and weighing totalization (Accumulation) functions. Selectable span calibration points

Compliance

- **Product Safety:** IEC/EN 61010-1
- **Electromagnetic Compatibility:** IEC/EN 61326-1 Class B, Basic environments

Accessories

RS232 Kit.....	30101019
Folding Column Kit.....	30101016
In-Use-Cover.....	30101017
Load Cell Cable Adapter Kit.....	30101021
SF40A Impact Printer.....	30064202
T4 Label Printer.....	30057588

Dimensions

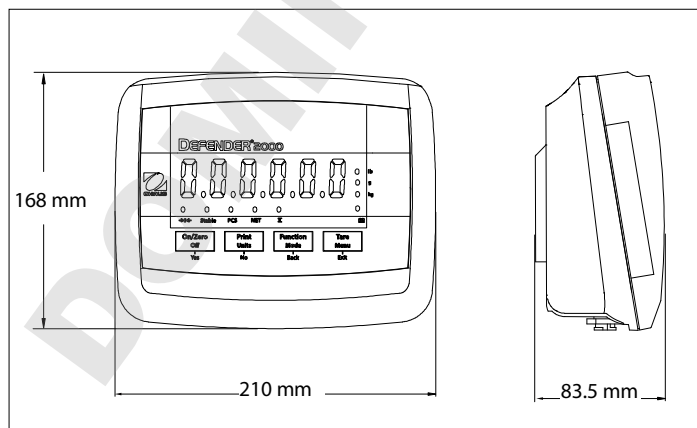

OHAUS Europe GmbH
Im Langacher 44
8606 Greifensee
Switzerland

e-mail: ssc@ohaus.com
Tel: 0041 22 567 53 19
e-mail: tsc@ohaus.com
Tel: 0041 22 567 53 20

www.ohaus.com
OHAUS Corporation is an ISO
9001:2008 manufacturer

ISO 9001:2008
Registered Quality
Management System

CH16B007

