

5 mL Screw Tube

1. Description

SPL Life Sciences is pleased to announce the release of the new 5 mL Screw Tube, self-standing type.

5 mL Screw Tube is ideal for experiments requiring larger sample volumes, between 1.5 mL and 5 mL.

It is sophisticatedly designed to prevent possible contamination, and to allow safe handling.

Amber provides optimal condition for storing/handling of light-sensitive samples and reagents.

5 ml Screw Tube is applicable to centrifuge independently, and can also be inserted into its adapter for 15 ml rotor.

2. Features

- ❖ Maximum safety and stability for centrifugation up to 25,000 × g (Cat. No. 51005, 51105, 56005, 56105)
- ❖ Conical Bottoms and Tight sealing screw cap
- ❖ Imprinted external graduations with marking area
- ❖ Amber type (Cat. No. 56005, 56105)
- ❖ Sterile (Cat. No. 51105, 53105, 56105)
- ❖ Skirted, self-standing type (Cat. No. 53005, 53105)

3. Functional Test

- ❖ Non-Pyrogenic : Passed
- ❖ RNase/DNase Free : Passed
- ❖ Human-DNA Free : Passed
- ❖ Sterility : Passed

4. Product Range

Clear							
Cat.No.	Type	Materials	Dimensions (mm)	Total Vol. (mL)	RCF Rating	Sterile	Packaging
51005	Conical	PP/HDPE	16.00 x 66.00	5.00	25,000 x g	-	100 / 200
51105	Conical	PP/HDPE	16.00 x 66.00	5.00	25,000 x g	+	100 / 200
53005	Skirted	PP/HDPE	16.00 x 69.10	5.00	-	-	100 / 200
53105	Skirted	PP/HDPE	16.00 x 69.10	5.00	-	+	100 / 200
Amber							
56005	Conical	PP/HDPE	16.00 x 66.00	5.00	25,000 x g	-	100 / 200
56105	Conical	PP/HDPE	16.00 x 66.00	5.00	25,000 x g	+	100 / 200

5. Certification

SPL Life Sciences hereby certifies that the product identified above, inspected to be in compliance with product quality specification and requirements as documented in our ISO 9001:2015 Quality Management System (K-QA-Q031478) in Korea.

6. Specifications & Technical Drawing

(1) 5 mL Screw Tube (#51005/51105/56005/56105)

- Specifications

	Dimensions	Materials	SterilesPackaging
Cap	Diameter: 21.35 mm Height: 11.00 mm	High-density polyethylene (HDPE)	<ul style="list-style-type: none"> ▪ Pieces/Sleeve: 100 ▪ Pieces/Case: 200
Body	Diameter: 15.20 mm Height: 66.30 mm Volume: 5.00 mL	Polypropylene (PP)	

- Technical Drawing

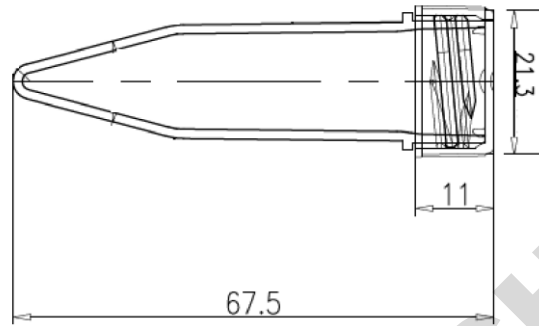

(2) 5 mL Screw Tube, skirted (#53005/53105)

- Specifications

	Dimensions	Materials	SterilesPackaging
Cap	Diameter: 21.35 mm Height: 11.00 mm	High-density polyethylene (HDPE)	<ul style="list-style-type: none"> ▪ Pieces/Sleeve: 100 ▪ Pieces/Case: 200
Body	Diameter: 15.50 mm Height: 69.10 mm Volume: 5.00 mL	High-density polyethylene (PP)	

- Technical Drawing

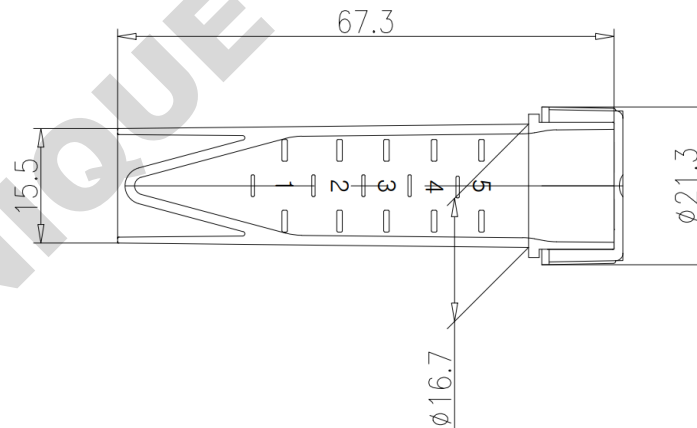

www.spllifesciences.com

For technical assistance, contact SPL R&D Center at:

Tel: +82-31-533-4800; Fax: +82-31-533-1430; e-mail: spl@ispl.co.kr

To place an order, contact your local distributor or

Tel: +82-31-533-4800; Fax: +82-31-533-1430; e-mail: business@ispl.co.kr

SPL-TDS-5ml Screw Tube

For Research Use Only. Not intended for use in diagnostic or therapeutic procedures.
© SPL Life Sciences Co., Ltd., Version 1, FEB. 14th, 2020