

Mobicap

Metallic mobile rolling cart equipped with 4 wheels - 2 locking wheels
Meuble de support roulant en métal, équipé de 4 roues dont 2 autobloquantes
Rolltisch aus Metall, mit vier Rollen, zwei davon feststellbar
Mueble de soporte móvil en metal, equipado con 4 ruedas cuyas 2 autoblocantes
Supporto mobile in acciaio elettrozincato , con 4 ruote di cui 2 autobloccanti

Product datasheet
Fiche produit
Ficha del producto
Produktdatenblatt
Scheda prodotto



Mobicap 320/321/391/481

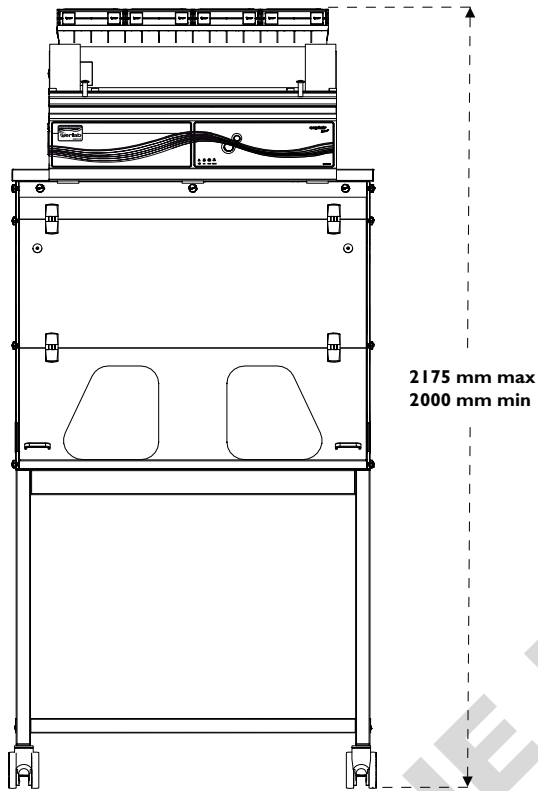

320/321

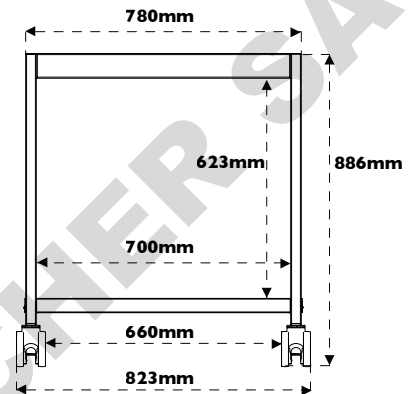

391

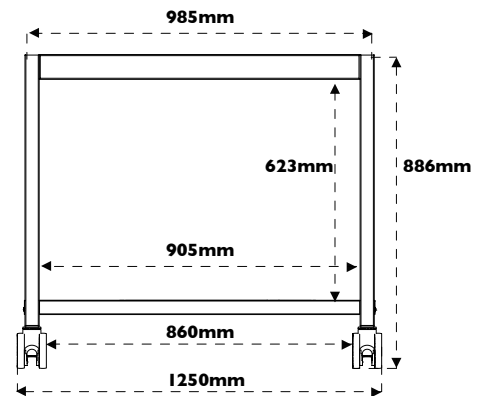

320/321/391/481

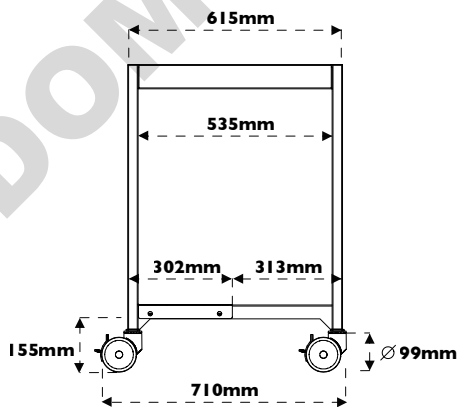

481

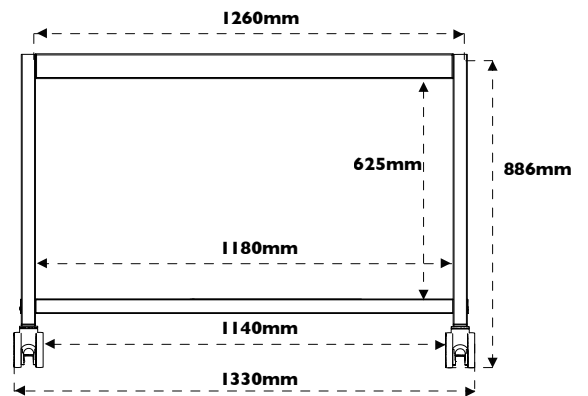

Mobicap 392

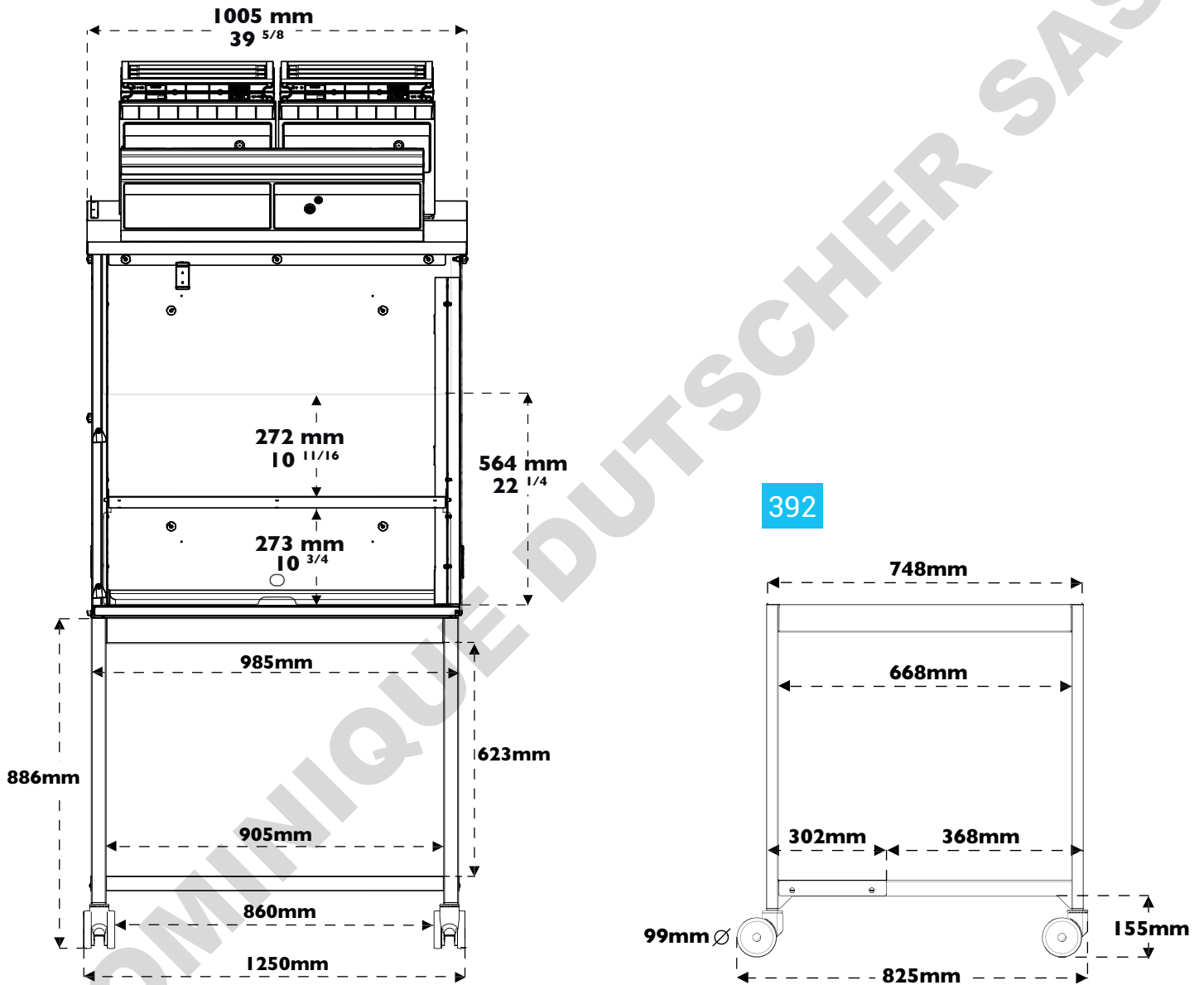



The Erlab Research and Development laboratory

About Erlab

Since 1968, **Erlab** has been a specialist, inventor and world leader in **ductless, zero-emission filtering fume hoods for laboratories** to provide total safety in chemical handling.

1 Erlab filtration

We provide technologies to protect laboratory staff from inhaling chemicals. This is made possible thanks to our **Research and Development (R&D) department**, which has continuously improved our filtration technology **for more than 50 years**. That's why, in 2009, we invented the **ERLAB ABOVE** label for tried and tested filtration technology.

2 The AFNOR NF X 15-211: 2009 standard

Erlab's filtration technology conforms to the **NF X 15-211: 2009 standard**, the industry's most demanding standard for molecular filtration, developed by a committee of independent scientists and specialized manufacturers.

This text imposes performance criteria linked to:

- Filtration efficiency
- Containment efficiency
- Air face velocity
- Documentation: **chemical listing**

3 The ESP programme

A set of three services included with the purchase of each device designed to ensure your safety.



eValiQuest Risk analysis – Determination of protection needs – Determination of ergonomic needs.



ValiPass Certified installation – Total safety for handling.



ValiGuard Ongoing monitoring – Preventative and maintenance inspections – Device reconfiguration based on protection needs – Development of handling.

4 Flex technology

The combination of molecular and particulate filtration technologies allows a single device to meet laboratories' protection needs. This innovation from Erlab's R&D department offers unprecedented **flexibility, versatility and value**. A single device can be reconfigured over time and easily reassigned to other applications.

5 Smart technology

Smart technology is a **simple and innovative** means of communication that improves safety. This technology uses a light and sound signal to indicate the user's level of protection. The advantages of the technology are:

1/ Light pulsation: Real-time communication via LED light pulses intuitively alerts the user to the device's operating status.

2/ Simplicity: One-touch activation.

3/ Detection system: The exclusive detection system continuously monitors filtration performance.

4/ Built-in monitoring: This service provides direct access to the **status, settings and history** of your device.

France
+33 (0) 2 32 09 55 80 | ventes@erlab.net

United States
+1 800-964-4434 | captairsales@erlab.com

China
+86 (0) 512 5781 4085 | sales.china@erlab.com.cn

Spain
+34 936 732 474 | export.south@erlab.net

Germany
0800 330 47 31 | export.north@erlab.net

United Kingdom
+44 (0) 1722 341 940 | export.north@erlab.net

Italy
+39 (0) 2 89 00 771 | export.south@erlab.net