

Minisart® Syringe Filters
The Easy Choice – Clean and Safe



turning science into solutions

Minisart® Syringe Filters

Removal of Particles and Microorganisms from Liquids and Gases

Sartorius offers Minisart® syringe filters for a wide range of applications. The filters are clean and safe as they are almost free of leachables and extractables. Additionally, they reliably remove particles and microorganisms with no leakage. Minisart® with PP housing is optimized for filtration prior to analytics and withstands even harsh solvents and chemicals. Minisart® with housing made of medical acrylic (MBS) are the perfect choice for sterile filtration and clarification of additives, buffers, reagents, drugs and gases.



DOMINIQUE DUTSCHER SAS







DOMINIQUE PUTSCHER SAS

Minisart® -Help-to-Find

Please refer to Minisart® RC, NY or SRP for the highest chemical compatibility, page 8.
 Please refer to Minisart® NML or Minisart® High Flow on page 12.
 Several additional Minisart® for venting and special purposes could be found on page 16.

Sample Composition	Aqueous		Aqueous Solvents		
	All Aqueous Solutions Buffers, Protein Analysis	All Aqueous Solutions Tissue Culture Media	Aqueous Solvent Mixtures Solvents	Solvent Mixtures Solvents	Solvents Gases Acids Bases
	SFCA Surfactant-Free Cellulose Acetate	PES Polyethersulfone	RC Regenerated Cellulose	NY Polyamide, Nylon	PTFE Polytetrafluoroethylene
	Hydrophilic			Hydrophobic	

Pore Sizes	Sterilization		Sample Preparation Clarification Particle Removal				Prefiltration	
	Small Bacteria Mycoplasma Colloids >0.1	UHPLC, etc. (Columns < 3 µm Particles) Bacteria	HPLC, etc. (Columns > 3 µm Particles) Particles	Particles Yeast Cells	Particles Yeast Cells	Particles Yeast Cells Platelets	Large Particles Rubber Grit Cells	Glass Prefilter Glass+Membrane Highly Particle- laden Samples
	0.1 µm	0.2 µm	0.45 µm	0.65 µm	0.8 µm	1.2 µm	5 µm	GF (Glass Fibre)

Sample Volume				
	1 – 200 ml	1 – 100 ml	0.5 – 15 ml	0.05 – 1 ml
	28 mm for up to 200 ml	25 mm for up to 100 ml	15 mm for up to 15 ml	4 mm for up to 1 ml

Minisart® Syringe Filters

A full range of filters dedicated for various filtration applications.

Sample Preparation
HPLC | UHPLC | Analytics



Elimination of particles from your samples prior to HPLC or other chromatographic analysis is essential in order to maintain the integrity of your chromatography column and to maximize its operating life time.

Minisart® syringe filters optimized for sample preparation consist of a PP housing and membrane components featuring maximum chemical compatibility and minimum extractables to ensure excellent results. Due to the typical range of volumes from less than 1 ml to 100 ml these filters are available in three different diameters with an effective filtration area of 0.07 cm², 1.7 cm² and 4.8 cm². See page 6.

Filtration of Aqueous Liquids Clarification | Sterile Filtration

For clarification and sterilization of liquids, filtration is the optimal method. It removes all microorganisms and particles reliably, without any effects on the ingredients, due to adsorption or decomposition.



For optimal results Minisart® filters made of MBS housing provide a choice of membranes with pore sizes ranging from 0.1 µm to 5 µm for high flow rates and lowest adsorption characteristics. The effective filtration area of 6.2 cm² for fastest filtration is the biggest amongst premium syringe filters and the MBS housing is color-coded for easy pore size identification. See page 10.

Medical Use and Sterile Venting Special Applications

Minisart® syringe filters are ideal for clarification of liquids laden with particles, e.g. for preparation of pharmaceuticals or infusion solutions. For sterilization and removal of particles from air and other gases, syringe filters are optimal for sterile venting of containers, bioreactors, fermenters and tubing systems in medical devices. Many Minisart® syringe filters have the CE mark of conformity (European directive) and are available with a wide choice of membranes, connectors and housing materials. See page 14.



Sartolab® Filters
Vacuum Filtration and Pressure Filtration Devices

See page 24.



Sample Preparation for Analytics

Reliable removal of Particles and Microorganisms from Liquids and Gases

Particle removal via filtration prior to analytics substantially increases the lifetime of your columns. Minisart® RC is optimized for aqueous liquids as well as solvents and is stable against DMSO, other amides, ketones, esters and ethers. Minisart® NY is exceptionally pure compared to other common polyamide (=nylon) filters and competitor products. For this products raw materials are used which do not interfere with standard analytical methods. Our coating-free hydrophobic PTFE membrane used in Minisart® SRP is suitable for venting applications as well as the leachable free clarification of very harsh chemicals.

Minisart® Features

- Low adsorption of analytes
- Maximum chemical compatibility
- Minimum extractables or leachables
- Bidirectional use possible
- 100% optical integrity test

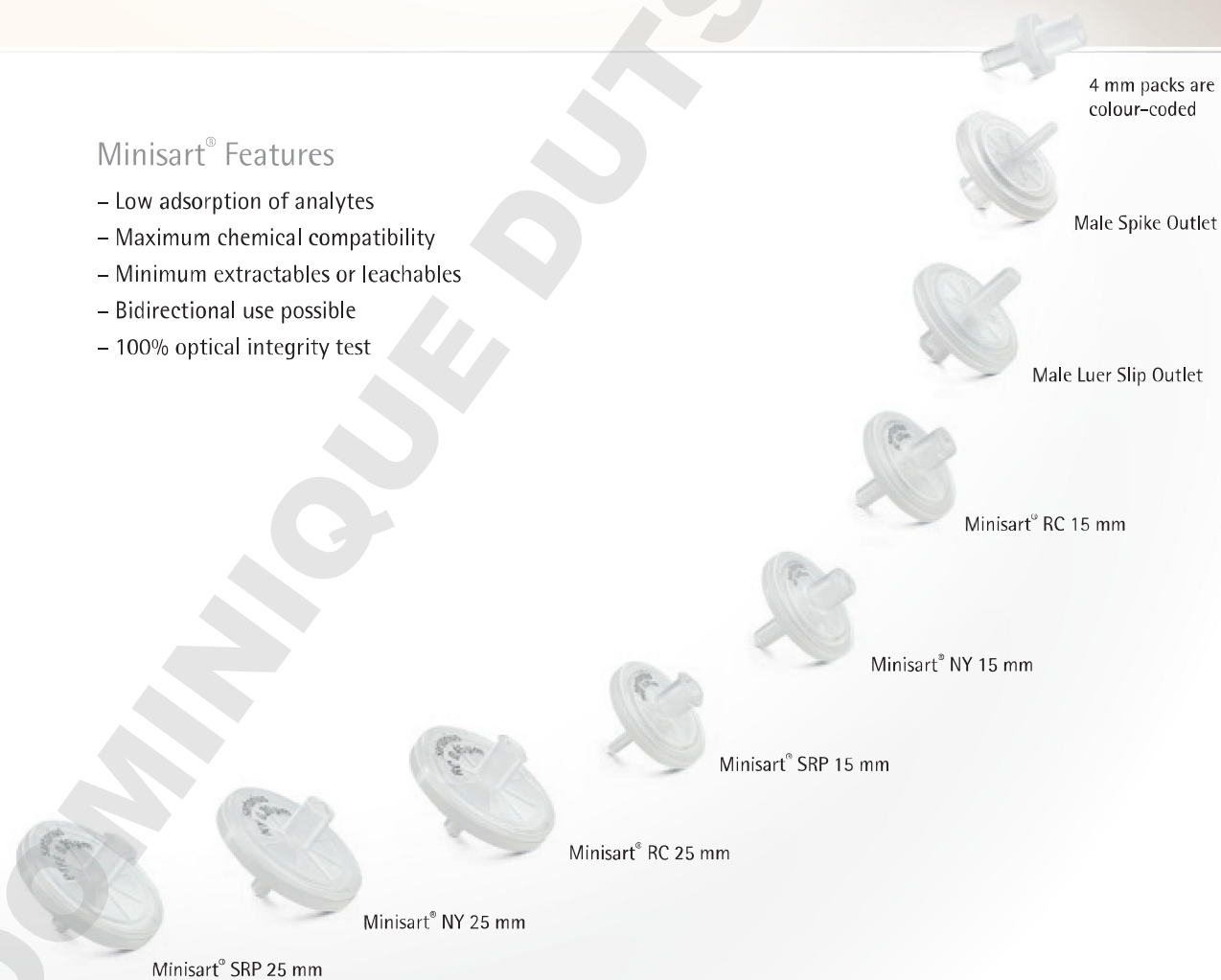



HPLC Certification

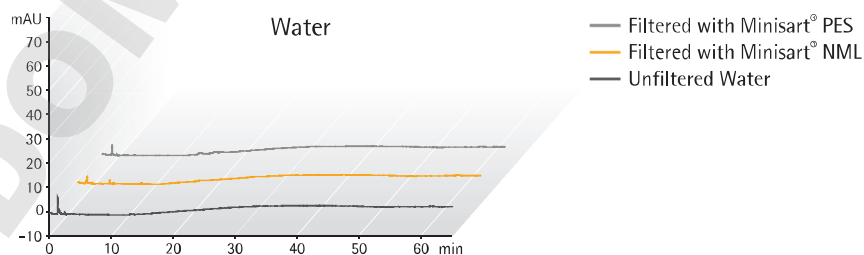
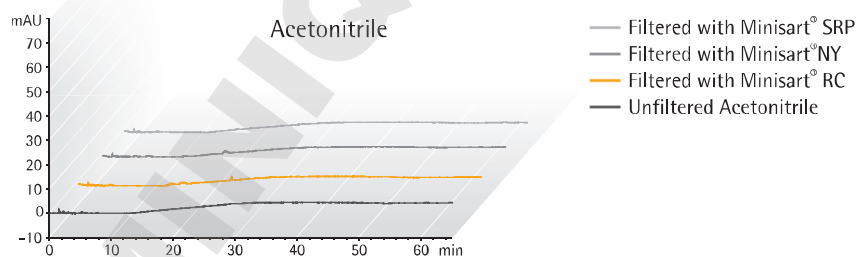
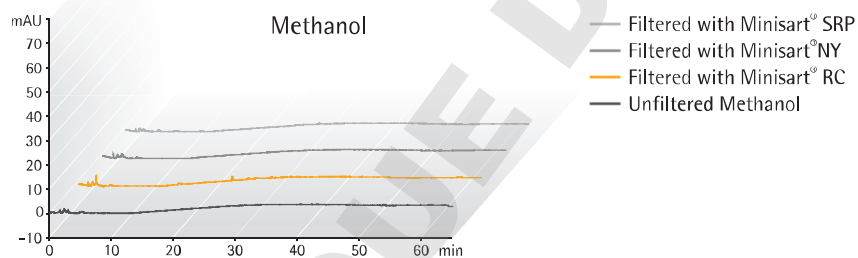

HPLC Procedure

Column
 – C18: 250 × 4,6 mm,
 – Flow Rate: 1 ml/min,
 – Wavelength: 220 nm

HPLC
 – Injection Volume: 20 µl,
 – Analysis Time: 65 min,
 – Temperature: 40°C,
 – Mobile Phases:
 A) Acetonitrile
 B) Water, Gradient:
 Hold 60% A for 10 min,
 60% to 95% A in 20 min,
 95% to 100% A in 35 min

Sample Preparation Chromatography

Ordering Information

Ø mm | EFD¹ | Membrane | Housing | Pore Size | Connector Outlet | Color | Printing | Sterile* | Qty | Pk | Order No.

Minisart® RC (Regenerated Cellulose)

25 mm	RC	PP	0.2 µm	Male Luer Slip	White, Printed	Yes	50	17764-----ACK
25 mm	RC	PP	0.2 µm	Male Luer Slip	White, Printed	No	50	17764-----K
25 mm	RC	PP	0.2 µm	Male Luer Slip	White, Printed	No	200	17764-----S
25 mm	RC	PP	0.2 µm	Male Luer Slip	White, Printed	No	500	17764-----Q
25 mm	RC	PP	0.45 µm	Male Luer Slip	White, Printed	No	50	17765-----K
25 mm	RC	PP	0.45 µm	Male Luer Slip	White, Printed	No	200	17765-----S
25 mm	RC	PP	0.45 µm	Male Luer Slip	White, Printed	No	500	17765-----Q
15 mm	RC	PP	0.2 µm	Male Luer Slip	White, Printed	Yes	50	17761-----ACK
15 mm	RC	PP	0.2 µm	Male Luer Slip	White, Printed	No	50	17761-----K
15 mm	RC	PP	0.2 µm	Male Luer Slip	White, Printed	No	500	17761-----Q
15 mm	RC	PP	0.45 µm	Male Luer Slip	White, Printed	No	50	17762-----K
15 mm	RC	PP	0.45 µm	Male Luer Slip	White, Printed	No	500	17762-----Q
4 mm	RC	PP	0.2 µm	Male Luer Slip	Blue Tray	No	50	17821-----K
4 mm	RC	PP	0.2 µm	Male Luer Slip	Blue Tray	No	500	17821-----Q
4 mm	RC	PP	0.45 µm	Male Luer Slip	Yellow Tray	No	50	17822-----K
4 mm	RC	PP	0.45 µm	Male Luer Slip	Yellow Tray	No	500	17822-----Q

Minisart® SRP (Hydrophobic PTFE)

25 mm	PTFE	PP	0.2 µm	Male Luer Slip	White, Printed	Yes	50	17575-----ACK
25 mm	PTFE	PP	0.2 µm	Male Luer Slip	White, Printed	No	50	17575-----K
25 mm	PTFE	PP	0.2 µm	Male Luer Slip	White, Printed	No	200	17575-----S
25 mm	PTFE	PP	0.2 µm	Male Luer Slip	White, Printed	No	500	17575-----Q
25 mm	PTFE	PP	0.45 µm	Male Luer Slip	White, Printed	No	50	17576-----K
25 mm	PTFE	PP	0.45 µm	Male Luer Slip	White, Printed	No	200	17576-----S
25 mm	PTFE	PP	0.45 µm	Male Luer Slip	White, Printed	No	500	17576-----Q
15 mm	PTFE	PP	0.2 µm	Male Spike	White, Printed	No	50	17558-----K
15 mm	PTFE	PP	0.2 µm	Male Spike	White, Printed	No	500	17558-----Q
15 mm	PTFE	PP	0.2 µm	Male Luer Slip	White, Printed	Yes	50	17573-----ACK
15 mm	PTFE	PP	0.2 µm	Male Luer Slip	White, Printed	No	50	17573-----K
15 mm	PTFE	PP	0.2 µm	Male Luer Slip	White, Printed	No	500	17573-----Q
15 mm	PTFE	PP	0.45 µm	Male Spike	White, Printed	No	50	17559-----K
15 mm	PTFE	PP	0.45 µm	Male Spike	White, Printed	No	500	17559-----Q
15 mm	PTFE	PP	0.45 µm	Male Luer Slip	White, Printed	No	50	17574-----K
15 mm	PTFE	PP	0.45 µm	Male Luer Slip	White, Printed	No	500	17574-----Q
4 mm	PTFE	PP	0.2 µm	Male Luer Slip	Blue Tray	No	500	17844-----Q
4 mm	PTFE	PP	0.45 µm	Male Luer Slip	Yellow Tray	No	50	17820-----K
4 mm	PTFE	PP	0.45 µm	Male Luer Slip	Yellow Tray	No	500	17820-----Q

Ø mm | EFD¹ | Membrane | Housing | Pore Size | Connector Outlet | Color | Printing | Sterile* | Qty | Pk | Order No.

Minisart® NY (Nylon) & NY25 Plus (Glass Fiber 0.7 µm² + Nylon)

25 mm	Nylon	PP	0.2 µm	Male Luer Slip	White, Printed	Yes	50	17845-----ACK
25 mm	Nylon	PP	0.2 µm	Male Luer Slip	White, Printed	No	500	17845-----Q
25 mm	Nylon	PP	0.45 µm	Male Luer Slip	White, Printed	Yes	50	17846-----ACK
25 mm	Nylon	PP	0.45 µm	Male Luer Slip	White, Printed	No	500	17846-----Q
15 mm	Nylon	PP	0.2 µm	Male Luer Slip	White, Printed	No	50	1776B-----K
15 mm	Nylon	PP	0.2 µm	Male Luer Slip	White, Printed	No	500	1776B-----Q
15 mm	Nylon	PP	0.45 µm	Male Luer Slip	White, Printed	No	50	1776C-----K
15 mm	Nylon	PP	0.45 µm	Male Luer Slip	White, Printed	No	500	1776C-----Q
25 mm	GF+Nylon	PP	0.2 µm	Male Luer Slip	White, Printed	No	50	1784B-----K
25 mm	GF+Nylon	PP	0.2 µm	Male Luer Slip	White, printed	No	500	1784B-----Q
25 mm	GF+Nylon	PP	0.45 µm	Male Luer Slip	White, printed	No	50	1784C-----K
25 mm	GF+Nylon	PP	0.45 µm	Male Luer Slip	White, printed	No	500	1784C-----Q

* Sterile Minisarts are individually packaged. If not stated otherwise, Minisarts have been sterilized by ethylene oxide. Minisarts not presterilized: RC, PTFE and Nylon can be sterilized by autoclaving at 121 °C for 30 min/or by using ethylene oxide (EO).

¹ EFD – Effective Filtration Diameter

² 0.7 µm = GF particle retention ≠ pore size!

For technical product specifications please see page 20.



Filtration of Aqueous Liquids – Clarification | Sterilization

Filtration is the Optimal Method for Clarification and Sterilization of Liquids.

Sterilization by filtration is the fastest solution for bacterial cell removal from liquids with minimal effect on the ingredients. Minisart® NML with surfactant-free cellulose acetate (SFCA) is the best choice for all aqueous solutions with a pH of 4–8. It combines fast flow rates with an exceptionally pure and leachable free membrane and is available in many different pore sizes also for the removal of larger particles. Minisart® High Flow with polyethersulfone (PES) is optimal for highest flow rates and a pH of 1–13. Due to the asymmetric membrane structure, the PES surface almost behaves like a pre-filter. Both Minisart® types NML and High Flow can be sterilized by ethylene oxide (EO) or gamma irradiation and are suitable for glueing and assembly to tubing. Minisart® NML in addition has the CE mark of conformity.

Minisart® Features

- Biggest effective filtration diameter (EFD) of 6.2 cm²
- Lowest adsorption
- Superior flow rate
- High total throughput
- Low hold-up volume
- Minimum extractables
- PVC-free
- Gamma irradiated or EO sterilized
- Bidirectional use possible
- 100% optical integrity test

Minisart® NML with SFCA



Minisart® High Flow with PES

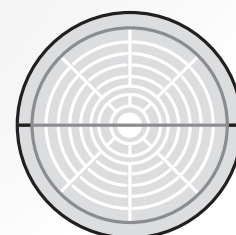

28 mm effective filtration diameter
33 mm housing diameter



Water Flow at 1 bar (ml/min); 15.4 psi;
0.45 μm Hydrophilic Membranes

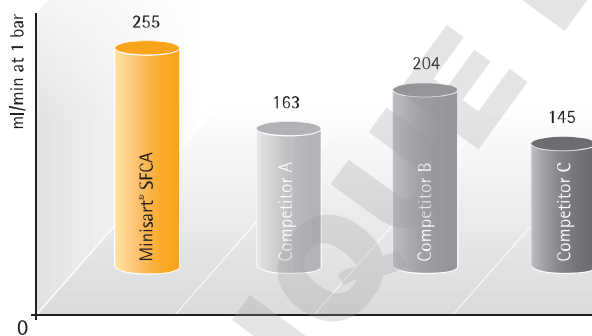

0.45 μm SFCA membrane compared with CA (Cellulose Acetate) or similar hydrophilic membranes of same pore size

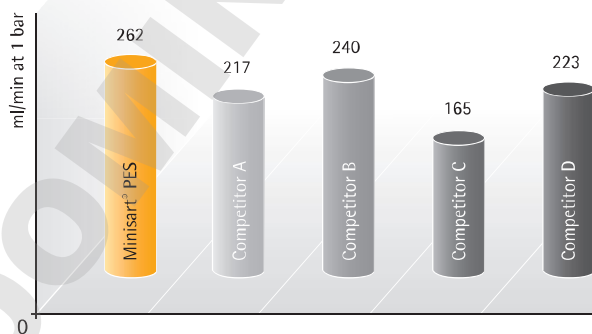

0.45 μm PES membrane compared with other PES membranes of same pore size

Preparation of Aqueous Liquids

Ordering Information

Ø mm	EFD ¹	Membrane	Housing	Pore Size	Connector	Outlet	Color	Printing	Sterile*	Qty Pk	Order No.	Marked?
------	------------------	----------	---------	-----------	-----------	--------	-------	----------	----------	----------	-----------	---------

Minisart® High Flow (PES – Polyethersulfone)

28 mm	PES	MBS	0.1 µm	Male Luer Lock	Dark Red	Yes	50	16553-----K	
28 mm	PES	MBS	0.22 µm	Male Luer Lock	Royal Blue	Yes#	50	16532-----GUK	
28 mm	PES	MBS	0.22 µm	Male Luer Lock	Royal Blue	Yes	50	16532-----K	
28 mm	PES	MBS	0.22 µm	Male Luer Slip	Royal Blue	Yes	50	16541-----K	
28 mm	PES	MBS	0.22 µm	Male Luer Lock	Royal Blue	No	500	16532-----Q	
28 mm	PES	MBS	0.22 µm	Male Luer Slip	Royal Blue	No	500	16541-----Q	
28 mm	PES	MBS	0.45 µm	Male Luer Lock	Amber	Yes	50	16537-----K	
28 mm	PES	MBS	0.45 µm	Male Luer Lock	Amber	No	500	16537-----Q	
28 mm	PES	MBS	0.45 µm	Male Luer Slip	Amber	Yes#	50	16533-----GUK	
28 mm	PES	MBS	0.45 µm	Male Luer Slip	Amber	Yes	50	16533-----K	
28 mm	PES	MBS	0.45 µm	Male Luer Slip	Amber	No	500	16533-----Q	

Minisart® NML (SFCA – Surfactant-free Cellulose Acetate)

28 mm	SFCA	MBS	0.2 µm	Male Luer Lock	Blue	Yes	50	16534-----K	CE-marked
28 mm	SFCA	MBS	0.2 µm	Male Luer Lock	Blue	Yes#	50	16534-----GUK	CE-marked
28 mm	SFCA	MBS	0.2 µm	Male Luer Lock	Blue	No	500	16534-----Q	CE-marked
28 mm	SFCA	MBS	0.2 µm	Male Luer Slip	Blue	Yes	50	17597-----K	CE-marked
28 mm	SFCA	MBS	0.2 µm	Male Luer Slip	Blue	No	500	17597-----Q	CE-marked
28 mm	SFCA	MBS	0.45 µm	Male Luer Lock	Yellow	Yes	50	16555-----K	CE-marked
28 mm	SFCA	MBS	0.45 µm	Male Luer Lock	Yellow	Yes#	50	16555-----GUK	CE-marked
28 mm	SFCA	MBS	0.45 µm	Male Luer Lock	Yellow	No	500	16555-----Q	CE-marked
28 mm	SFCA	MBS	0.45 µm	Male Luer Slip	Yellow	Yes	50	17598-----K	CE-marked
28 mm	SFCA	MBS	0.45 µm	Male Luer Slip	Yellow	No	500	17598-----Q	CE-marked
28 mm	SFCA	MBS	0.65 µm	Male Luer Slip	Pink	Yes	50	16569-----K	
28 mm	SFCA	MBS	0.8 µm	Male Luer Lock	Green	Yes	50	16592-----K	
28 mm	SFCA	MBS	0.8 µm	Male Luer Lock	Green	Yes#	50	16592-----GUK	
28 mm	SFCA	MBS	0.8 µm	Male Luer Lock	Green	No	500	16592-----Q	
28 mm	SFCA	MBS	1.2 µm	Male Luer Lock	Red	Yes	50	17593-----K	
28 mm	SFCA	MBS	1.2 µm	Male Luer Lock	Red	No	500	17593-----Q	
28 mm	SFCA	MBS	5 µm	Male Luer Lock	Brown	Yes	50	17594-----K	CE-marked
28 mm	SFCA	MBS	5 µm	Male Luer Lock	Brown	No	500	17594-----Q	

∅ mm	EFD ¹	Membrane	Housing	Pore Size	Connector Outlet	Color Printing	Sterile*	Qty Pk	Order No.	Marked?
------	------------------	----------	---------	-----------	------------------	------------------	----------	----------	-----------	---------

Minisart® NML Plus (Glass Fiber 0.7 µm² + SFCA)

28 mm	GF+SFCA	MBS	0.2 µm	Male Luer Lock	Blue	Yes	50	17823-----K
28 mm	GF+SFCA	MBS	0.2 µm	Male Luer Lock	Blue	No	500	17823-----Q
28 mm	GF+SFCA	MBS	0.45 µm	Male Luer Lock	Yellow	Yes	50	17829-----K
28 mm	GF+SFCA	MBS	0.45 µm	Male Luer Lock	Yellow	No	500	17829-----Q
28 mm	GF+SFCA	MBS	1.2 µm	Male Luer Lock	Red	No	500	17825-----Q
28 mm	GF	MBS	0.7 µm ²	Male Luer Lock	White	No	50	17824-----K
28 mm	GF	MBS	0.7 µm ²	Male Luer Lock	White	No	500	17824-----Q

* Sterilized Minisarts are individually packaged. If not stated otherwise, Minisarts are sterilized by ethylene oxide.
 #-Mark indicates sterilization by gamma irradiation.
 Minisarts not presterilized: PES, SFCA, GF+SFCA and GF can be sterilized by ethylene oxide or gamma irradiation.

¹ EFD – Effective Filtration Diameter

² 0.7 µm = GF particle retention ≠ pore size!

For technical product specifications please see page 22.



Special Applications – Medical Use & Venting

Make Your Choice from a Broad Range of Pore Sizes, Materials and Formats

Bacterial cell removal or particulate removal from liquids including medical drugs can easily be performed with Minisart® syringe filters. Minisart® has minimal effect on the ingredients of the filtered solution. Minisart® NML and Ophthalsart with surfactant-free cellulose acetate (SFCA) and Minisart® HY and SRP with hydrophobic PTFE have the CE mark of conformity and are frequently used for sterile filtration of aqueous and oily ear- or eye-solutions and other drugs. Minisart® NML with 5 µm pore sizes removes particulates or coagulates in dissolved medicals prior to injection offering highest total throughput and late clogging under sterile conditions. Hydrophobic PTFE filters are suitable for venting purposes and are additionally available in special formats with activated carbon.



Minisart® Features

- 100% optical integrity test
- Low adsorption
- Minimum extractables
- Particulate-free
- PVC-free
- Gamma irradiated or EO sterilized
- Many CE-marked types
- Bidirectional use possible
- Many configurations available





Pressure-Hold Test

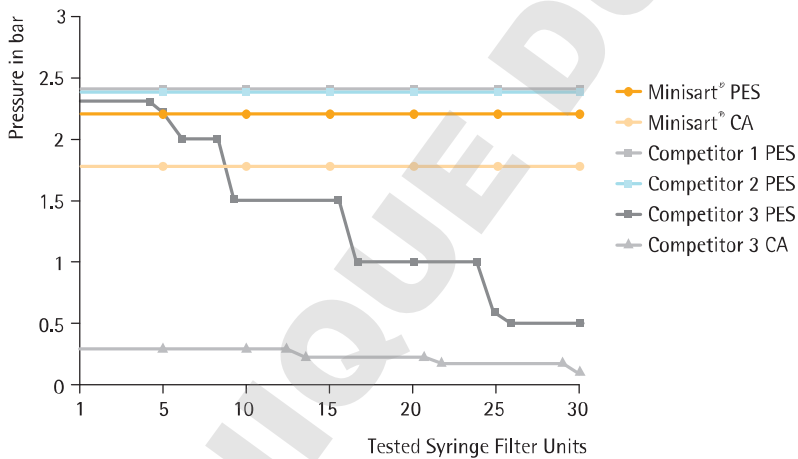

Method: Pressure-hold tests were performed by connecting pre-wetted syringe filter units to a 10-fold pressure device with manometer. The applied pressure equated 4/5 of the bubble point. Units failed the test if they released air bubbles before reaching 4/5 of minimum bubble point. These units were remeasured to determine at which pressure air bubbles appear.

Result: Testing the pressure-hold capability of syringe filters revealed that many of competitor 3's filters are dysfunctional and not intact. Filtration performed with such filters lead to non-sterile filtrates or filtrates without an appropriate removal of particles.



Biocompatibility Certificate Minisart[®] HY



Biocompatibility Certificate Minisart[®] NML



Declaration of Conformity Minisart[®]

Minisart® Syringe Filters – Specials

Ordering Information

∅ mm	EFD ¹	Membrane	Housing	Pore Size	Connector Outlet	Color	Printing	Sterile*	Qty Pk	Order No.	Marked?
Minisart® NML (SFCA – Cellulose Acetate) Aqueous Filtration											
28 mm	SFCA	MBS		0.2 µm	Male Luer Lock	Blue		Yes	50	16534-----K	CE-marked
28 mm	SFCA	MBS		0.2 µm	Male Luer Lock	Blue		Yes#	50	16534-----GUK	CE-marked
28 mm	SFCA	MBS		0.2 µm	Male Luer Lock	Blue		No	500	16534-----Q	CE-marked
28 mm	SFCA	MBS		0.2 µm	Male Luer Slip	Blue		Yes	50	17597-----K	CE-marked
28 mm	SFCA	MBS		0.2 µm	Male Luer Slip	Blue		No	500	17597-----Q	CE-marked
28 mm	SFCA	MBS		0.45 µm	Male Luer Lock	Yellow		Yes	50	16555-----K	CE-marked
28 mm	SFCA	MBS		0.45 µm	Male Luer Lock	Yellow		Yes#	50	16555-----GUK	CE-marked
28 mm	SFCA	MBS		0.45 µm	Male Luer Lock	Yellow		No	500	16555-----Q	CE-marked
28 mm	SFCA	MBS		0.45 µm	Male Luer Slip	Yellow		Yes	50	17598-----K	CE-marked
28 mm	SFCA	MBS		0.45 µm	Male Luer Slip	Yellow		No	500	17598-----Q	CE-marked
28 mm	SFCA	MBS		5 µm	Male Luer Lock	Brown		Yes	50	17594-----K	CE-marked
Minisart® Ophthalsart (SFCA – Cellulose Acetate) Aqueous Filtration											
28 mm	Ophthalsart	MBS		0.2 µm	Male Luer Slip	Pink		Yes	50	17528-----K	CE-marked
Minisart® High Flow (PES – Polyethersulfone) Aqueous Filtration											
28 mm	PES	MBS		0.1 µm	Male Luer Lock	Dark Red		Yes	50	16553-----K	
Minisart® PES (Polyethersulfone) Aqueous Filtration											
15 mm	PES	PP		0.22 µm	Male Luer Slip	White		Yes	50	1776D-----ACK	
Minisart® Air (Hydrophobic PTFE) Venting											
15 mm	PTFE	MBS		0.2 µm	Male Luer Slip	Yellow		No	500	1751A-----Q	
15 mm	PTFE	MBS		0.2 µm	Male Luer Slip + Needle	Yellow		Yes#	50	16596-----HNK	
Minisart® HY (hydrophobic PTFE) CE-marked Venting & Gas Filtration											
26 mm	PTFE	MBS		0.2 µm	Male Luer Lock	Clear		Yes	50	16596-----HYK	CE-marked
26 mm	PTFE	MBS		0.2 µm	Male Luer Lock	Clear		No	500	16596-----HYQ	CE-marked
26 mm	PTFE	MBS		0.2 µm	Male Luer Lock ^a	Clear		No	500	16599-----HYQ	CE-marked
26 mm	PTFE	MBS		0.2 µm	Hose Barbs ^b	Clear		No	500	40078-----Q	CE-marked
26 mm	PTFE	MBS		1 µm	Male Luer Lock	Clear		No	500	1659A-----HYQ	
26 mm	PTFE	MBS		1 µm	Hose Barbs ^b	Clear		No	500	1659B-----HYQ	

Ø mm	EFD ¹	Membrane	Housing	Pore Size	Connector Outlet	Color Printing	Sterile*	Qty Pk	Order No.	Marked?
------	------------------	----------	---------	-----------	------------------	------------------	----------	----------	-----------	---------

Minisart® Acticosart with Dome Reservoir + Hydrophobic PTFE Venting & Ultracleaning of Gases

26 mm		active carbon	MBS	0.45 µm	Male Luer Slip ^a	Blue	No	500	17840-----Q	
-------	--	---------------	-----	---------	-----------------------------	------	----	-----	-------------	--

Minisart® SRP (Hydrophobic PTFE) CE-marked Venting & Gas Filtration

25 mm		PTFE	PP	0.2 µm	Male Luer Slip	White, Printed	Yes	50	17575-----ACK	CE-marked
25 mm		PTFE	PP	0.2 µm	Hose Barb	White	No	500	1757A-----Q	

* Sterilized Minisarts are individually packaged. If not stated otherwise, Minisarts are sterilized by ethylene oxide.

#-mark indicates sterilization by gamma irradiation

Minisarts NOT presterilized: SFCA can be sterilized by ethylene oxide or gamma irradiation, PTFE can be sterilized by ethylene oxide.

^a Connector inlet: Male Luer slip (all other Minisarts have female luer lock inlets)

^b Hose barbs, inlet and outlet, 5 mm diameter

¹ EFD – Effective Filtration Diameter

For technical product specifications please see pages 20 and 22.

Do you need other pack sizes?
Are you looking for special versions or sterilization requirements?
You need other inlet and | or outlet connectors?

Please contact us to learn more about additionally available Minisart® configurations.

Chemical Compatibility

	Material								Minisart® Types									
	PES membrane	SFCA membrane	PTFE membrane	RC membrane	Nylon membrane	GF depth filter	Housing MBS	Housing PP	Minisart® HighFlow	Minisart® NML Ophthalsart	Minisart® NML Plus	Minisart® NML GF	Minisart® HY	Minisart® Air	Minisart® RC	Minisart® NY	Minisart® NY Plus	Minisart® SRP
Filter Membrane	PES	SFCA	PTFE	RC	PA				PES	SFCA	SFCA		PTFE	RC	PA	PA	PTFE	PES
Pre-Filter						GF			-	-	GF	GF	-	-	-	GF	-	-
Housing Material							MBS	PP	MBS	MBS	MBS	MBS	MBS	PP	PP	PP	PP	PP
Sterilization																		
Ethylene oxide	++	++	++	++	++	++	++	++	++	++	++	++	++	++	++	++	++	++
Gamma irradiation	++	++	- ¹	++	-	++	++	-	++	++	++	++	- ¹	-	-	-	-	-
Autoclaving 121 °C, 30 min	++	++	++	++	++	++	-	++	-	-	-	-	-	++	++	++	++	++
Solvents																		
Acetone	-	-	++	++	++	++	-	++	-	-	-	-	-	++	++	++	++	-
Acetonitrile	-	-	++	++	++	++	-	++	-	-	-	-	-	++	++	++	++	-
Gasoline	+	++	++	++	++	++	+	++	+	+	+	+	+	++	++	++	++	+
Benzene	+	+	++	++	++	++	-	++	-	-	-	-	-	++	++	++	++	+
Benzyl alcohol	+	+	++	++	++	++	-	+	-	-	-	-	-	++	++	++	++	+
n-Butyl acetate	-	-	++	++	++	++	-	++	-	-	-	-	-	++	++	++	++	-
n-Butanol	++	++	++	++	++	++	+	++	+	+	+	+	+	++	++	++	++	++
Cellosolve	+	-	++	++	++	++	-	++	-	-	-	-	-	++	++	++	++	+
Chloroform	-	-	++	++	++	++	-	++	-	-	-	-	-	++	++	++	++	-
Cyclohexane	-	-	++	++	++	++	+	+	-	-	-	+	+	+	+	+	+	-
Cyclohexanone	-	-	++	++	++	++	-	+	-	-	-	-	-	+	+	+	+	-
Diethylacetamide	-	-	++	++	++	++	-	++	-	-	-	-	-	++	++	++	++	-
Diethyl ether	-	+	++	++	++	++	-	++	-	-	-	-	-	++	++	++	++	-
Dimethyl formamide	-	-	++	+	+	++	-	++	-	-	-	-	-	+	+	+	++	-
Dimethylsulfoxide	-	-	++	++	++	++	-	++	-	-	-	-	-	++	++	++	++	-
Dioxane	-	-	++	++	++	++	-	++	-	-	-	-	-	++	++	++	++	-
Ethanol, 98%	++	++	++	++	++	++	-	++	-	-	-	-	-	++	++	++	++	++
Ethyl acetate	-	-	++	++	++	++	-	+	-	-	-	-	-	+	+	+	+	-
Ethylene glycol	++	+	++	++	++	++	++	++	++	+	+	++	++	++	++	++	++	++
Formamide	++	-	++	+	++	++	++	++	++	-	-	++	++	+	++	++	++	++
Glycerin	++	++	++	++	++	++	++	++	++	++	++	++	++	++	++	++	++	++
n-Heptane	+	+	++	++	++	++	++	+	+	+	+	+	++	+	+	+	+	+
n-Hexane	+	+	++	++	++	++	++	+	+	+	+	+	++	+	+	+	+	+
Isobutanol	++	+	++	++	++	++	-	++	-	-	-	-	-	++	++	++	++	++
Isopropanol	++	++	++	++	++	++	-	++	-	-	-	-	-	++	++	++	++	++
Isopropyl acetate	-	-	++	++	++	++	-	++	-	-	-	-	-	++	++	++	++	-
Methanol, 98%	+	-	++	++	++	++	-	++	-	-	-	-	-	++	++	++	++	+
Methyl acetate	-	-	++	++	++	++	-	+	-	-	-	-	-	+	+	+	+	-
Methylene chloride	-	-	++	++	++	++	-	++	-	-	-	-	-	++	++	++	++	-
Methyl ethyl ketone	-	+	++	++	++	++	-	+	-	-	-	-	-	+	+	+	+	-
Methyl isobutyl ketone	-	-	++	++	++	++	-	+	-	-	-	-	-	+	+	+	+	-
Monochlorobenzene	+	+	++	++	++	++	-	+	-	-	-	-	-	+	+	+	+	+
Nitrobenzene	-	-	++	++	+	++	-	+	-	-	-	-	-	+	+	+	+	-
n-Pentane	++	++	++	++	++	++	+	+	+	+	+	+	+	+	+	+	+	+
Perchloroethylene	-	-	++	++	++	++	-	+	-	-	-	-	-	+	+	+	+	-

	Material								Minisart® Types										
	PES membrane	SFCA membrane	PTFE membrane	RC membrane	Nylon membrane	GF depth filter	Housing MBS	Housing PP	Minisart® HighFlow	Minisart® NML Ophthalsart	Minisart® NML Plus	Minisart® NML GF	Minisart® HY	Minisart® Air	Minisart® RC	Minisart® NY	Minisart® NY Plus	Minisart® SRP	Minisart® PES
Filter Membrane	PES	SFCA	PTFE	RC	PA				PES	SFCA	SFCA		PTFE	RC	PA	PA	PA	PTFE	PES
Pre-Filter						GF			-	-	GF	GF	-	-	-	GF	-	-	
Housing Material							MBS	PP	MBS	MBS	MBS	MBS	MBS	PP	PP	PP	PP	PP	PP
Solvents (continued)																			
Pyridine	-	-	++	++	++	++	-	++	-	-	-	-	-	++	++	++	++	++	-
Carbon tetrachloride	-	-	++	++	++	++	-	+	-	-	-	-	-	+	+	+	+	+	-
Tetrahydrofuran	-	-	++	++	++	++	-	++	-	-	-	-	-	++	++	++	++	++	-
Toluene	-	+	++	++	++	++	-	+	-	-	-	-	-	+	+	+	+	+	-
Trichloroethane	-	-	++	++	+	++	-	+	-	-	-	-	-	+	+	+	+	+	-
Trichloroethylene	-	+	++	++	++	++	-	+	-	-	-	-	-	+	+	+	+	+	-
Xylene	-	+	++	++	++	++	-	+	-	-	-	-	-	+	+	+	+	+	-
Acids																			
Acetic acid, 25%	+	+	++	++	-	++	+	++	+	+	+	+	+	++	-	-	++	+	
Acetic acid, 80%	-	-	++	+	-	++	-	+	-	-	-	-	-	+	-	-	+	-	
Hydrofluoric acid, 25%	+	-	++	+	-	++	+	+	+	-	-	+	+	+	-	-	+	+	
Hydrofluoric acid, 50%	+	-	++	+	-	++	-	+	-	-	-	-	-	+	-	-	+	+	
Perchloric acid, 25%	-	-	++	-	-	++	-	+	-	-	-	-	-	-	-	-	+	-	
Phosphoric acid, up to 10%	+	+	++	-	-	++	+	+	+	+	+	+	+	-	-	-	+	+	
Phosphoric acid, 86%	+	+	++	-	-	++	-	+	-	-	-	-	-	-	-	-	+	+	
Nitric acid, 30%	+	-	++	-	-	++	+	+	+	-	-	+	+	-	-	-	+	+	
Nitric acid, conc.	-	-	++	-	-	++	-	-	-	-	-	-	-	-	-	-	-	-	
Hydrochloric acid, 15%	++	+	++	-	-	++	+	+	+	+	+	+	+	-	-	-	+	+	
Hydrochloric acid, 20%	++	-	++	-	-	++	+	+	+	-	-	+	+	-	-	-	+	+	
Sulfuric acid, 25%	+	-	++	+	-	++	++	++	+	-	-	++	++	+	-	-	++	+	
Sulfuric acid, 98%	-	-	++	-	-	++	-	-	-	-	-	-	-	-	-	-	-	-	
Trichloroacetic acid, 25%	-	-	++	++	-	++	-	+	-	-	-	-	-	+	-	-	+	-	
Bases																			
Ammonia, 1N	++	+	++	+	++	++	+	++	+	+	+	+	+	+	++	++	++	++	++
Ammonium hydroxide, 25%	+	+	++	+	++	+	-	+	-	-	-	-	-	+	+	+	+	+	
Potassium hydroxide, 32%	++	-	++	-	+	+	-	++	-	-	-	-	-	-	+	+	++	++	
Sodium hydroxide, 1N	++	-	++	+	++	+	-	++	-	-	-	-	-	+	++	+	++	++	
Sodium hydroxide, 32%	++	-	++	-	+	-	-	+	-	-	-	-	-	+	-	-	+	+	
Aqueous solutions																			
Formaldehyde, 30%	+	++	++	+	++	++	+	+	+	+	+	+	+	+	+	+	+	+	
Sodium hypochlorite, 5%	++	-	++	-	-	++	+	+	+	-	-	+	+	-	-	-	+	+	
Hydrogen peroxide, 35%	++	-	++	-	-	++	+	++	+	-	-	+	+	-	-	-	++	++	
pH range																			
pH 1-14	-	-	++	-	-	++	-	++											
pH 1-13	++	-	++	-	-	++	-	++											
pH 3-14	+	-	++	+	++	++	-	++											
pH 3-12	++	-	++	++	++	++	+	++											
pH 4-8	++	++	++	++	++	++	++	++											

Legend
High Resistance ++
Limited Resistance +
Not Resistant -

¹ gamma irradiation feasible for Minisart® Air

Contact time: 24 hours at 20 °C. Chemical compatibilities can be influenced by various factors. Therefore, we recommend that you confirm compatibility with the liquid you want to filter by performing a trial filtration run before you start your actual filtration.

Minisart® with PP Housing

Technical Specifications

Specifications for

Minisart® RC | SRP | NY | PES with 4 | 15 | 25 mm membrane filtration area Ø

Housing material	Polypropylene (PP)
Membranes	RC = Regenerated Cellulose NY = Polyamide SRP = hydrophobic PTFE = Polytetrafluoroethylene PES = Polyethersulfone
Glass fiber pre-filter	NY Plus: Ultrapure quartz, 0.7 µm particle retention
Application limits	Max. recommended operating pressure 4.5 bar 65 psi
Housing burst pressure	> 7 bar 102 psi
Max. temperature	121°C, 30 min (autoclavable)
Sterilization	Non-sterile Minisart® can be autoclaved or sterilized by ethylene oxide sterilization (EO)

Minisart® type with regards to membrane	RC 0.2 µm	RC 0.2 µm	RC 0.45 µm	SRP 0.2 µm
Non-sterile packs: 50 (K), 200 (S), 500 (Q), 1000 (R) sterile packs: individual packaged, 50 (ACK)	K S Q R	ACK	K S Q R	K S Q ACK
Bubble point (≥)	with water 3.0 bar 44 psi	with water 4.6 bar 67 psi	with water 2.0 bar 29 psi	with ethanol 1.4 bar 20 psi
Flow rate, 4 mm Ø = 0.07 cm² filter area Hold-up volume¹: 5–10 µl (► ml/min)				
with water at 1 bar	0.5	–	1.5	– ³
with methanol at 1 bar	1.5	–	3.0	2.0
with air at 0.1 bar	– ²	–	– ²	30
Flow rate, 15 mm Ø = 1.7 cm² filter area Hold-up volume¹: 30–100 µl (► ml/min)				
with water at 1 bar	20	10	40	– ³
with methanol at 1 bar	55	25	105	55
with air at 0.1 bar	– ²	– ²	– ²	800
Flow rate, 25 mm Ø = 4.8 cm² filter area Hold-up volume¹: 100–200 µl (► ml/min)				
with water at 1 bar	80	50	160	– ³
with methanol at 1 bar	160	90	325	160
with air at 0.1 bar	– ²	– ²	– ²	1800
Water penetration point	–	–	–	> 4.0 bar 58 psi ³
Sterile filtration capability acc. to BCT	no ⁵	yes	no	yes
Pyrogen free according to USP				yes
Cytotoxicity (17575-ACK)	No inhibition with MRC-5 (human lung cells) and L929			

¹ Hold-up volume after air purge.

² Hydrophilic membranes can filter dry air or gas but become impermeable to air or gas when wetted!

³ Hydrophobic membranes cannot be wetted with aqueous solutions unless you overcome their water penetration point or pre-wet them using an organic solvent (e.g. ethanol)

⁴ PES is suitable for solutions only containing up to 30% MeOH

⁵ According to bacterial challenge test (BCT) with 10⁷ Brevundimonas diminuta. Non-sterile RC Minisart® types are optimized for sample preparation and are not suitable for sterile filtration according to the BCT. All other non-sterile Minisart® types with 0.2 mm pore size can be sterilized by autoclaving or EO before use for sterile filtration.



SRP 0.45 µm K S Q	NY 0.2 µm K Q R ACK	NY 0.45 µm K Q R ACK	NY Plus 0.2 µm K Q	NY Plus 0.45 µm K Q	PES 0.2 µm K Q ACK
with ethanol 0.9 bar 13 psi	with water 3.0 bar 44 psi	with water 2.0 bar 29 psi	with water 3.0 bar 44 psi	with water 2.0 bar 29 psi	with water 3.2 bar 46 psi
– ³	–	–	–	–	1.5
4.5	–	–	–	–	– ⁴
60	–	–	–	–	– ²
– ³	20	40	–	–	40
150	40	110	–	–	– ⁴
1600	– ²	– ²	–	–	– ²
– ³	50	100	50	100	100
260	70	200	70	200	– ⁴
3000	– ²	– ²	– ²	– ²	– ²
> 3.0 bar 44 psi ³	–	–	–	–	–
no	yes	no	yes	no	yes

Minisart® with MBS Housing

Technical Specifications

Specifications for

Minisart® High Flow | NML | NML Plus with 28 mm accessible membrane filtration area Ø, 100 – 150 µl hold-up volume¹

Minisart® HY | Acticosart with 26 mm accessible membrane filtration area Ø, 100 – 150 µl hold-up volume¹

Minisart® Air with 15 mm accessible membrane filtration area Ø, 100 µm hold-up volume¹

Housing material	Methacrylate butadiene styrene (MBS)
Membranes	High Flow: PES = Polyethersulfone, NML: (SF) CA = (Surfactant-free) Cellulose Acetate, NML Plus: (SF) CA = (Surfactant-free) Cellulose Acetate, HY Acticosart Air: hydrophobic PTFE = Polytetrafluoroethylene
Glass fiber pre-filter	NML Plus: Binder-free GF, 0.7 µm particle retention
Application limits	High Flow: Max. recommended operating pressure 6.0 bar 87 psi NML, NML Plus, HY, Air: Max. recommended operating pressure 4.5 bar 65 psi Acticosart: Max. recommended operating pressure 1 bar 14.5 psi
Housing burst pressure	> 7 bar 102 psi (not determined for Acticosart)
Max. temperature	60°C, not autoclavable
Sterilization	Non-sterile Minisart® High Flow, NML, NML Plus can be or sterilized by ethylene oxide (EO) or Gamma sterilization Non-sterile Minisart® HY, Acticosart, Air* can be sterilized by ethylene oxide (EO)

Minisart® type with regards to membrane	PES 0.1 µm	PES 0.2 µm	PES 0.45 µm	CA 0.2 µm	CA 0.45 µm	CA 0.65 µm	CA 0.8 µm
Non-sterile packs: 500 (O, HYQ), 1000 (R), sterile packs: individual packaged, 50 (K, GUK, HYK, HNK)	K	K GUK Q	K GUK Q	K GUK Q	K GUK Q	K	K GUK Q
Bubble point (≥)	with water 5.0 bar 73 psi	with water 3.2 bar 46 psi	with water 2.0 bar 29 psi	with water 3.2 bar 46 psi	with water 2.0 bar 29 psi	with water 1.3 bar 19 psi	with water 0.8 bar 12 psi
Flow rate for^{2 3} (► ml/min)							
28 mm Ø with water at 1 bar	40	140	220	60	180	250	400
15 mm Ø with air at 0.1 bar	–	–	–	–	–	–	–
26 mm Ø with air at 0.1 bar	–	–	–	–	–	–	–
Water penetration point	–	–	–	–	–	–	–
Sterile filtration capability⁴ acc. to BCT	yes	yes	no	yes	no	no	no
Pyrogen free according to USP				yes	yes		
Cytotoxicity	No inhibition with MRC-5 (human lung cells) and L929						

¹ Hold-up volume after air purge.

² Hydrophilic membranes can filter dry air or gas but become impermeable to air or gas when wetted!

³ Hydrophobic membranes cannot be wetted with aqueous solutions unless you overcome their water penetration point.

⁴ According to bacterial challenge test (BCT) with 10⁷ Brevundimonas diminuta. All non-sterile Minisart® types listed above can be sterilized according to the sterilization recommendation in this table.

* Minisart® Air can be sterilized by Gamma sterilization according to the following parameters: Range 25 – 40 kGy (validated with 50 kGy).



CA 1.2 µm K Q	CA 5.0 µm K Q	GF+CA 0.2 µm K Q	GF+CA 0.45 µm K Q	GF+CA 1.2 µm Q	GF 0.7 µm K Q	PTFE 0.2 µm HYK HYQ Q	PTFE 1.0 µm HYQ	Actico- sart Q	PTFE (Air) 0.2 µm Q HNK
with water 0.7 bar 10 psi	with water 0.4 bar 6 psi	with water 3.2 bar 46 psi	with water 2.0 bar 29 psi	with water 0.7 bar 10 psi	with water 0.5 bar 7 psi	with ethanol 1.4 bar 20 psi	with ethanol 0.5 bar 7 psi	with ethanol 0.9 bar 13 psi	with ethanol 0.9 bar 13 psi
500	600	60	160	350	450	-	-	-	-
-	-	-	-	-	-	-	-	-	2000
-	-	-	-	-	-	2000	4000	2300	-
-	-	-	-	-	-	> 4.0 bar 58 psi ³	> 1.5 bar 22 psi ³	n.a.	> 3.0 bar 44 psi ³
no	no yes	yes	no	no	no	yes	no	n.a.	yes
						yes			

Sartolab® Filters

Vacuum Filtration and Pressure Filtration Devices

Sartolab® P20 Pressure Filtration Devices with 0.2 µm SFCA or 0.22 µm PES membrane with and without GF pre-filter are convenient filtration units for 500 ml to 5 L sample volumes. Especially Sartolab® P20 can be used to collect the filtrate in any required container or for in-line filtration. The polycarbonate housing and membrane components are suitable for many aqueous solutions. The GF pre-filter types are mainly suitable for environmental samples with high particle load prior to analytics.



Sartolab® Vacuum Filtration Devices with 0.1 µm and 0.22 µm PES membranes are convenient filtration units for 150 ml to 1 L sample volume. Sartolab® RF as a complete system includes receiver flasks. Sartolab® BT is a bottle top filter without receiver flasks enabling customers to use their own receiver bottles and to expand the filtration capacity depending on the particle load of the filtered liquid by filling more than one receiver flask. Sartolab® 150V is a disposable vacuum filter with a pleated 0.22 µm PES membrane which is suitable for filtration of up to 15 L liquid.



Please contact us to learn more about Sartolab® filtration units and additional Sartorius filtration solutions.

Confidence[®] – Validation Services

Our Services at a Glance

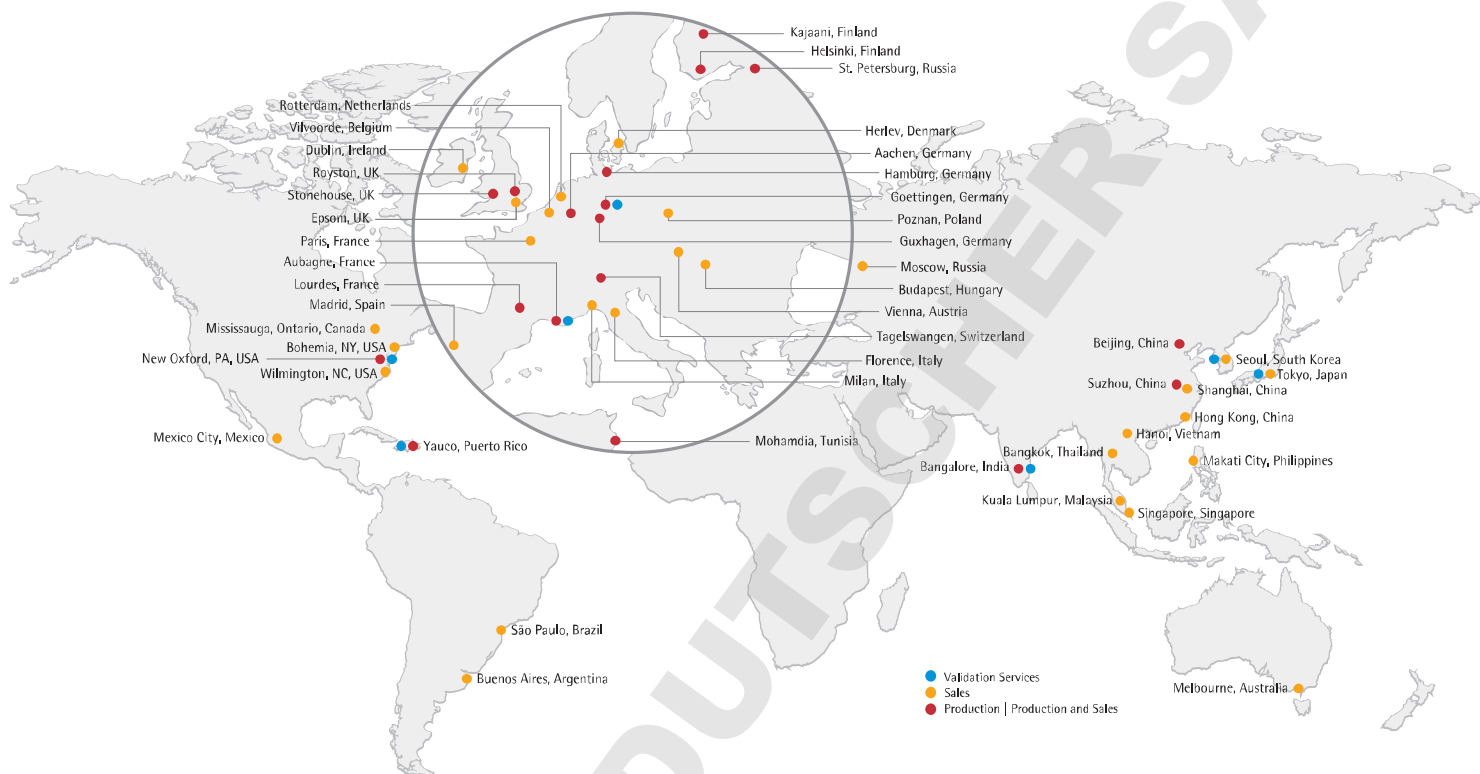

Multi-site laboratories offer globally integrated Validation Services.

Every Sartorius Stedim Biotech product used in critical steps in the pharmaceutical industry is manufactured with complete traceability of materials. The extensive data obtained in our validation guides and extractables guides form a comprehensive basis for the safety assessment of your respective process and drug product. Given the latest developments in regulatory requirements, our in-depth knowledge of actual drug product testing is a key element of our Confidence[®] Validation Services. Our product array includes, but is not limited to, the following:

Filter Elements	Fluid Management Containers	Polymer-based Process Components
Extractables Leachables Studies	Extractables Leachables Studies	Extractables Leachables Studies
Physico-Chemical Studies	Physico-Chemical Studies	
Microbiological Studies	Microbiological Studies	

Time To Market

Make the choice that helps bring your products to market rapidly – on time, every time. Ask us about our 30 day commitment program.

Explore your possibilities – we continue to lead and innovate in the field of validation studies to increase the added value of our services offered to the biopharmaceutical and pharmaceutical industries.

Visit us at www.sartorius-stedim.com/confidence

Sales and Service Contacts

For further contacts, visit www.sartorius.com

Europe

Germany

Sartorius Lab Instruments
GmbH & Co. KG
Weender Landstrasse 94–108
37075 Goettingen

Phone +49.551.308.0
Fax +49.551.308.3289

France Et Suisse Romande

Sartorius France
2, rue Antoine Laurent de Lavoisier
ZA de la Gaudriée
91410 Dourdan

Phone +33.1.70.62.50.00
Fax +33.1.64.59.76.39

Austria

Sartorius Austria GmbH
Modecenterstrasse 22
1030 Vienna

Phone +43.1.7965760.0
Fax +43.1.7965760.24

Belgium

Sartorius Belgium N.V.
Rue Colonel Bourg 105
1030 Bruxelles

Phone +32.2.756.06.90
Fax +32.2.481.84.11

Finland & Baltics

Sartorius Biohit Liquid Handling Oy
Laippatie 1
00880 Helsinki

Phone +358.9.755.951
Fax +358.9.755.95.200

Hungary

Sartorius Hungária Kft.
Kagyló u. 5.
2092 Budakeszi

Phone +3623.457.227
Fax +3623.457.147

Ireland

Sartorius Ireland Ltd.
Unit 41, The Business Centre
Stadium Business Park
Ballycoolin Road
Dublin 11

Phone +353.1.8089050
Fax +353.1.8089388

Italy

Sartorius Italy S.r.l.
Viale A. Casati, 4
20835 Muggiò (MB)

Phone +39.039.4659.1
Fax +39.039.4659.88

Netherlands

Sartorius Netherlands B.V.

Phone +31.30.60.53.001
Fax +31.30.60.52.917

info.netherlands@sartorius.com

Poland

Sartorius Poland sp.z o.o.
ul. Wrzesinska 70
62-025 Kostrzyn

Phone +48.61.6473830
Fax +48.61.6473839

Russian Federation

LLC "Sartorius ICR" and LLC "Biohit"
Uralskaya str. 4, Lit. B
199155, Saint-Petersburg

Phone +7.812.327.5.327
Fax +7.812.327.5.323

Spain Et Portugal

Sartorius Spain, S.A.
Avda. de la Industria, 32
Edificio PAYMA
28108 Alcobendas (Madrid)

Phone Spain +34.902.123.367
Phone Portugal +351.800.855.800
Fax Spain +34.91.358.96.23
Fax Portugal +351.800.855.799

Switzerland

Sartorius Mechatronics Switzerland AG
Ringstrasse 24a
8317 Tagelswangen (ZH)

Phone +41.44.746.50.00
Fax +41.44.746.50.50

U.K.

Sartorius UK Ltd.
Longmead Business Centre
Blenheim Road, Epsom
Surrey KT19 9QQ

Phone +44.1372.737159
Fax +44.1372.726171

Ukraine

LLC "Biohit"
Post Box 440 "B"
01001 Kiev, Ukraine

Phone +380.44.411.4918
Fax +380.50.623.3162

Americas

USA

Sartorius Corporation
5 Orville Drive, Suite 200
Bohemia, NY 11716

Phone +1.631.254.4249
Toll-free +1.800.635.2906
Fax +1.631.254.4253

Argentina

Sartorius Argentina S.A.
Int. A. Ávalos 4251
B1605ECS Munro
Buenos Aires

Phone +54.11.4721.0505
Fax +54.11.4762.2333

Brazil

Sartorius do Brasil Ltda
Avenida Senador Vergueiro 2962
São Bernardo do Campo
CEP 09600-000 - SP- Brasil

Phone +55.11.4362.8900
Fax +55.11.4362.8901

Canada

Sartorius Canada Inc.
2179 Dunwin Drive #4
Mississauga, ON L5L 1X2

Phone +1.905.569.7977
Toll-Free +1.800.668.4234
Fax +1.905.569.7021

Mexico

Sartorius de México S.A. de C.V.
Circuito Circunvalación Poniente
No. 149
Ciudad Satélite
53100, Estado de México
México

Phone +52.5555.62.1102
Fax +52.5555.62.2942

Asia | Pacific

Australia

Sartorius Australia Pty. Ltd.
Unit 5, 7-11 Rodeo Drive
Dandenong South Vic 3175

Phone +61.3.8762.1800
Fax +61.3.8762.1828

China

Sartorius Scientific
Instruments (Beijing) Co., Ltd.
33 Yu An Road, Airport Industrial Park
Zone B,
Shunyi District, Beijing 101300,
P.R.China

Phone +86.10.8042.6300
Fax +86.10.8042.6486

Hong Kong

Sartorius Hong Kong Ltd.
Unit 1012, Lu Plaza
2 Wing Yip Street
Kwun Tong
Kowloon, Hong Kong

Phone +852.2774.2678
Fax +852.2766.3526

India

Sartorius Weighing India Pvt. Ltd.
#69/2-69/3, NH 48, Jakkasandra,
Nelamangala Tq
562 123 Bangalore, India

Phone +91.80.4350.5250
Fax +91.80.4350.5253

Japan

Sartorius Japan K.K.
4th Fl., Daiwa Shinagawa North Bldg.
8-11, Kita-Shinagawa 1-chome
Shinagawa-ku, Tokyo, 140-0001 Japan

Phone +81.3.3740.5408
Fax +81.3.3740.5406

Malaysia

Sartorius Malaysia Sdn. Bhd
Lot L3-F-3B, Enterprise 4
Technology Park Malaysia
Bukit Jalil
57000 Kuala Lumpur, Malaysia

Phone +60.3.8996.0622
Fax +60.3.8996.0755

Singapore

Sartorius Singapore Pte. Ltd
1 Science Park Road,
The Capricorn, #05-08A,
Singapore Science Park II
Singapore 117528

Phone +65.6872.3966
Fax +65.6778.2494

South Korea

Sartorius Korea Ltd.
8th Floor, Solid Space B/D,
PanGyoYeok-Ro 220, Bundang-Gu
SeongNam-Si, GyeongGi-Do, 463-400

Phone +82.31.622.5700
Fax +82.31.622.5799

Thailand

Sartorius (Thailand) Co. Ltd.
129 Rama 9 Road,
Huaykwang
Bangkok 10310

Phone +66.2643.8361-6
Fax +66.2643.8367



◀ www.sartorius.com