

NOTES

1. MATERIAL: Aluminum; any grade acceptable
2. FINISH: glass bead blast and Type III hard anodize
3. COLOR: medium grey

REVISION HISTORY		DATE
REV.	DESCRIPTION	

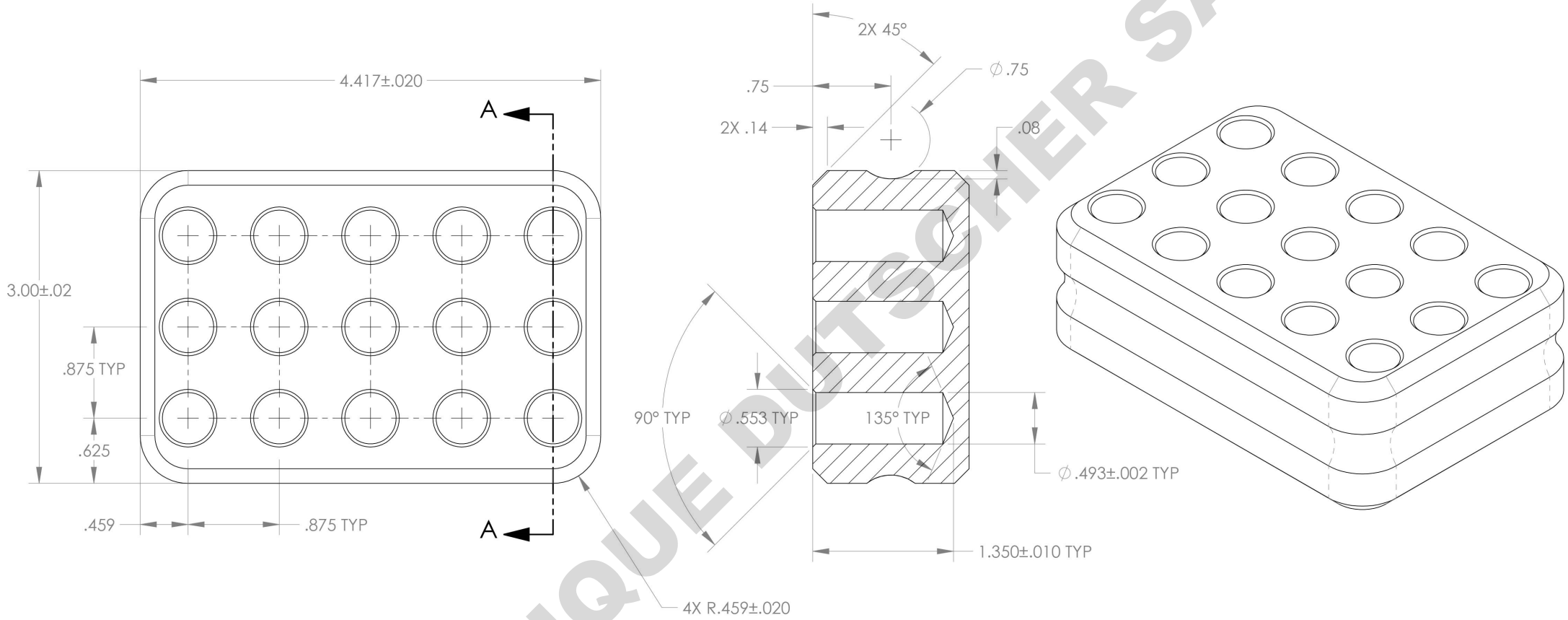

SECTION A-A

15 well cryo

DIMENSIONAL TOLERANCES UNLESS OTHERWISE SPECIFIED NOTE: DO NOT SCALE DRAWING		.X = ±0.1 .XX = ±0.01 .XXX = ±0.005	ANGLES = ±0.5° FRACTIONS = ±1/32	
MATERIAL SEE NOTES		FINISH SEE NOTES		
THIS DRAWING IS FURNISHED IN CONFIDENCE ON THE EXPRESS UNDERSTANDING THAT NEITHER IT NOR ANY REPRODUCTION THEREOF WILL BE DISCLOSED TO OTHERS OR USED FOR THE PURPOSE OF MANUFACTURE OR PROCUREMENT OF THE ARTICLE OR PART SHOWN HEREON.				
CLIENT		PROJECT #		DRWN MSR
				DATE 2014DEC12
				PART NUMBER TBD
		SCALE 1:1	UNITS INCH	SHEET 2 OF 6
			SIZE B	