

Baoding Shenchen Precision Pump Co., Ltd.

Add: No.103, Building 2, Pivot Industrial Park, FuXing East Road, Baoding,China.

Website: www.good-pump.com

Tel: 0086-312-6780681

Fax: 0086-312-6780636

Basic Peristaltic Pump- Lab M Series

Model No.: Lab M1, Lab M3, Lab M6



Acceptable Pump Head: YZ1515x, YZ2515x, SN Series, MC Series



Baoding Shenchen Precision Pump Co., Ltd.

Add: No.103, Building 2, Pivot Industrial Park, FuXing East Road, Baoding,China.

Website: www.good-pump.com

Tel: 0086-312-6780681

Fax: 0086-312-6780636

Product Introduction:

The second generation basic type peristaltic pump, with ABS engineering plastic housing, streamlined body design, more fashion sense. Speed range: 0.5-600rpm/min, suitable for various pump heads. Flow rate range: 0.00034-2280ml/min. Membrane keypad control, multiple external control for selection. Support RS232/RS485 (standard Modbus protocol) communication, it is easy to connect with computer, PLC, HMI etc.

Function and Features:

- 3 digital LED display the motor speed.
- Membrane keypad control, not only adjust speed manually, but also control automatically through external interface.
- Full speed button: with full filling and emptying function.
- Timing test function, time range: 0.5-999s, setting test time freely, can be used for simple dispensing.
- Internal isolate external control design. External control signal have active signal and passive signal, users can use it freely.
- RS232 and RS485 communication for option. The pump can be controlled by PC through RS232 and serial debugging software, control the pump start/stop, direction and speed. To achieve dispensing and filling function. It also can feedback pump working status according with external control request.
- Big torque, low consumption, strong adaptability.
- Good performance drive circuit, good cooling condition, low noise, working stable, power down memory function.
- Super strong anti-jamming feature, wide voltage design, suitable for complex power supply environment.
- Circuit board spray with three anti-paint. Anti-dust, anti-moisture, anti-static, resist corrosion.

Technical Specification:

<u>Flow rate range</u>	<u>LabM1: 0.00034~570ml/min</u> <u>LabM3:0.00034-1330ml/min</u> <u>LabM6:0.00034-2280ml/min</u>
<u>Speed range</u>	<u>0.1-600rpm</u>
<u>Speed resolution</u>	<u>0.1rpm</u>
<u>Back suction angle</u>	<u>0-360°</u>
<u>Testing time range</u>	<u>0.5s – 999s</u>
<u>Outlet pressure</u>	<u>0.1Mpa (0.86-1.0mm wall thickness tubing)</u>

Baoding Shenchen Precision Pump Co., Ltd.

Add: No.103, Building 2, Pivot Industrial Park, FuXing East Road, Baoding, China.

Website: www.good-pump.com

Tel: 0086-312-6780681

Fax: 0086-312-6780636

	0.1-0.27Mpa (1.6-2.4mm wall thickness tubing)
<u>Motor type</u>	<u>Stepper motor</u>
<u>Circuit system</u>	<u>Shenchen-M-CIR</u>
<u>Control system</u>	<u>Shenchen-M-EMB</u>
<u>Display</u>	<u>3 Digital LED display</u>
<u>Control method</u>	<u>Membrane keypad</u>
<u>External control speed signal</u>	<u>0-5V, 0-10V, 4-20mA for option</u>
<u>Start/stop, direction signal</u>	<u>Passive switch signal, such as foot pedal switch</u> <u>Default 24V</u>
<u>Communication interface</u>	<u>RS232/RS485 support MODBUS protocol (RTU mode)</u>
<u>Output interface</u>	<u>Output motor working status (Open-Collector output)</u>
<u>Power supply</u>	<u>220V±10%, 50Hz/60Hz (standard),</u> <u>110V±10%, 50Hz/60Hz (optional)</u>
<u>Drive dimension</u>	<u>261.4 x 157.3 x 230.7mm (L x W x H)</u>
<u>Drive weight</u>	<u>4.40kg</u>
<u>Power consumption</u>	<u><50W</u>
<u>Environment temperature</u>	<u>0-40°C</u>
<u>Relative humidity</u>	<u><80%</u>
<u>IP rate</u>	<u>IP31</u>

Product Composition and Flow Rate:

Drive	Speed Range	Pump Head	Tubing Size	Flow Rate (mL/min)
Lab M1	0.5-150rpm	YZ1515x	13#,14#,19#, 16#,25#,17#, 18#	0.035~570
		YZ2515x	15#, 24#	0.85~435
		MC1-MC12	ID:0.13-3.17mm, Wall thickness: 0.8-1.0mm	0.00034-45
		SN25/15	14#, 16#, 25#	0.12-375
Lab M3	0.5-350rpm	YZ1515x	13#,14#,19#, 16#,25#,17#, 18#	0.035~1330
		YZ2515x	15#, 24#	0.85~1015
		MC1-MC12	ID:0.13-3.17mm, Wall thickness: 0.8-1.0mm	0.00034-45
		SN25/15	14#, 16#, 25#	0.12-875
Lab M6	0.5-600rpm	YZ1515x	13#,14#,19#, 16#,25#,17#, 18#	0.035~2280
		YZ2515x	15#, 24#	0.85~1740
		MC1-MC12	ID:0.13-3.17mm, Wall thickness: 0.8-1.0mm	0.00034-45
		SN25/15	14#, 16#, 25#	0.12-1500

Baoding Shenchen Precision Pump Co., Ltd.

Add: No.103, Building 2, Pivot Industrial Park, FuXing East Road, Baoding,China.

Website: www.good-pump.com

Tel: 0086-312-6780681

Fax: 0086-312-6780636

Product Dimension

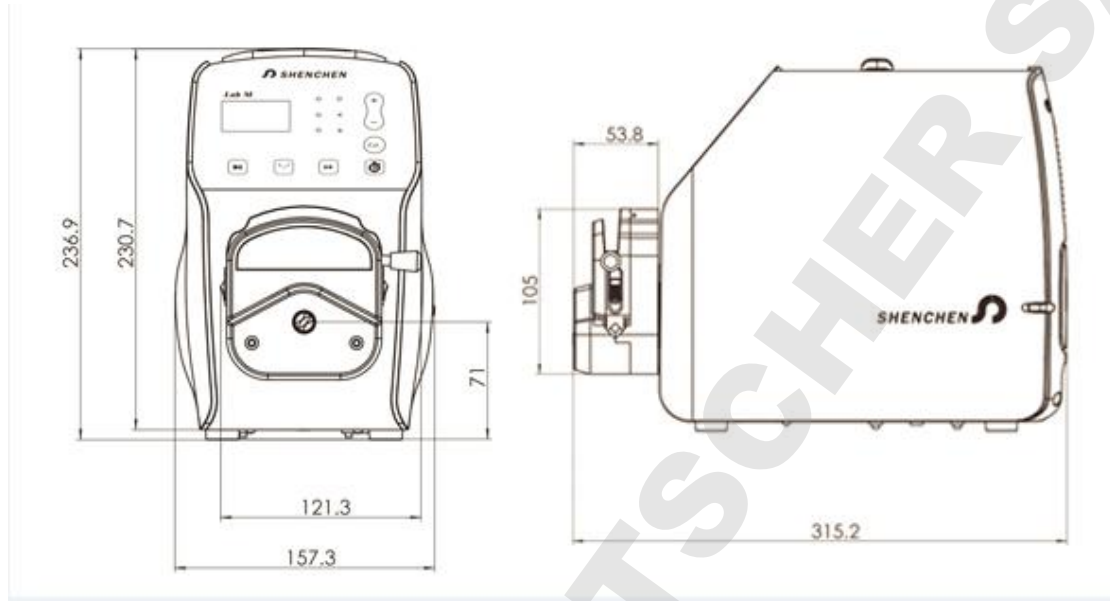

Baoding Shenchen Precision Pump Co., Ltd.