

IncuSafe

CO₂ Incubators

230 L



MCO-230AIC-PE



Optimising cell culture outcomes and reproducibility

IncuSafe CO₂ Incubators provide precise control of CO₂ concentration and accurate, uniform, and highly responsive temperature control within the chamber. During cell culturing the inCu-saFe germicidal interior and SafeCell UV lamp work continuously to prevent contamination.

Precise & Regulated Environment

InCu-saFe and SafeCell UV both function to actively prevent contamination. The Direct Heat and Air Jacket System regulates the temperature whilst the Dual IR sensor controls the CO₂ level.

Time-Saving Decontamination

The high-speed decontamination system uses vaporised hydrogen peroxide and UV light. It cleans the chamber of the incubator safely in less than three hours, achieving a minimal 6 log reduction of major contaminants.

Ease of Use & Increased Capacity

A full colour LCD touch-screen allows full control even with gloved hands. Transfer of data is easy via a USB port. The easy-to-clean interior features fully rounded corners and integrated shelf supports.



Optimum Cell Growth

Outstanding quality and performance for successful cell growth, optimal results and reproducibility. Perfect fit for the strictest and most sensitive protocols.

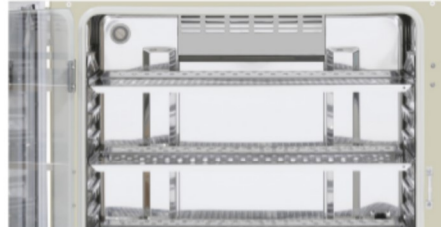

Efficient Workflows

Complete laboratory procedures and experiments more efficiently with less incubator downtime. Ideal for commercial applications.



Scale-up experiments

The increased capacity offers the possibility to utilise the incubator from R&D to clinical trials and manufacturing.

IncuSafe CO₂ Incubators



Direct Heat and Air Jacket System

Achieves accurate, uniform, and highly responsive temperature control within the chamber, providing exceptional uniformity and rapid recovery after door-openings.

Dual IR CO₂ Sensor

The incubator's Dual IR sensor and P.I.D control enables ultra-fast CO₂ recovery, without overshoot, even following multiple door-openings.

Active Background Decontamination

The exclusive inCu-saFe copper-enriched stainless steel alloy interior offers the germicidal properties of copper and the durability of stainless steel. The optional, isolated, SafeCell UV lamp decontaminates circulating air and water in the humidifying pan, without harming cultured cells.

Condensation Management

The 'dew stick'—controlled by Peltier technology—condenses water on its surface, which then drips into the humidifying pan, preventing unwanted condensation in the chamber and possible contamination.

Cleanroom-compatibility

The MCO-230AICUVH-PE is classified as ISO class 5.0 for usage in a cleanroom. Cleanroom classification was determined in accordance with ISO 14644-1 - Part 14: Assessment of suitability for use of equipment by airborne particle concentration.

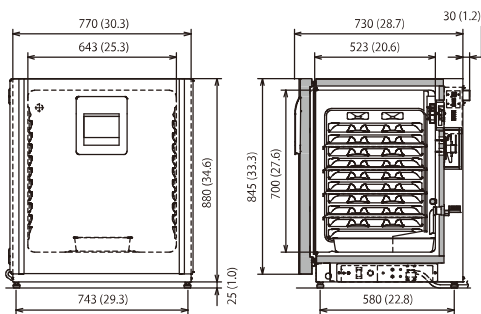

EEA, Switzerland and Turkey only



For medical use

The MCO-230AIC series is certified as a Class IIa Medical Device (93/42/EEC and 2007/47/EC). Applicable countries: Austria, Belgium, Cyprus, Denmark, Finland, France, Germany, Ireland, Italy, Liechtenstein, Luxembourg, Malta, the Netherlands, Spain, Switzerland and the United Kingdom only



For laboratory use

Applicable countries: EEA countries, Switzerland and Turkey



PHC Europe B.V.

Nijverheidsweg 120 | 4879 AZ Etten-Leur | Netherlands
T: +31 (0) 76 543 3839 | F: +31 (0) 76 541 3732

www.phchd.com/eu/biomedical

Model Number	MCO-230AIC-PE	MCO-230AICUV-PE	MCO-230AICUVH-PE**	
External Dimensions (W x D x H) ¹⁾	mm	770 x 730 x 905		
Internal Dimensions (W x D x H)	mm	643 x 523 x 700		
Volume	liters	230		
Net Weight	kg	90		
Classification				
ISO clean room classification ⁴⁾		5.0		
Performance				
Temperature Control Range & Fluctuation	°C	AT +5 - +50, ±0.1		
Temperature Uniformity ²⁾	°C	±0.25		
CO ₂ Control Range & Fluctuation	%	0 - 20, ±0.15		
Humidity Level & Fluctuation	%RH	95, ±5		
Sterilisation Method		H ₂ O ₂ Decontamination		
Control				
Temperature Sensor		Thermistor		
CO ₂ Sensor		Dual IR		
Display		LCD Touch Screen		
Construction				
Exterior Material		Painted Steel (rear cover not painted)		
Interior Material		Stainless Steel Copper-Enriched Alloy		
Insulation Material		Extruded polystyrene		
Heating Method		Direct Heat & Air Jacket System		
Outer Door	qty	1		
Outer Door Lock		Optional	Optional	Standard
Field Reversible Door		Included		
Inner Door	qty	1 gas tight - made of tempered glass		
Shelves	qty	4 x Stainless Steel Copper-enriched Alloy		
Shelf Dimensions (W x D x H)	mm	620 x 450 x 12		
Max. Load per Shelf	kg	7		
Max. Shelf Capacity	qty	10		
Access Port	qty	1		
Access Port Position		Rear		
Access Port Diameter	∅ mm	30		
Alarms (R = Remote Alarm, V = Visual Alarm, B = Buzzer Alarm)				
Power Failure		R		
Out of Temperature Setting		V-B-R		
High Temperature		V-B-R		
Out of CO ₂ Setting		V-B-R		
Door open		V-B		
Electrical and Noise Level				
Power Supply	V	230		
Frequency	Hz	50		
Noise Level ³⁾	dB	25		
Options				
SafeCell UV [®] System		MCO-170UVS-PE ⁴⁾	Standard	
H ₂ O ₂ Decontamination Board		MCO-170HB-PE ⁴⁾	Standard	
Electric Door Lock with Password		MCO-170EL-PW ⁴⁾	Standard	
H ₂ O ₂ Vapor Generator		MCO-HP-PW ⁴⁾		
H ₂ O ₂ Reagent, pack of 6 bottles		MCO-H202-PE		
CO ₂ Gas Pressure Regulator		MCO-010R-PW		
Automatic CO ₂ Cylinder Changeover System		MCO-216C-PW		
Semi-automatic one point Gas Calibration Kit		MCO-SG-PW		
InCu-saFe [®] Shelf		MCO-230ST-PW		
InCu-saFe [®] Half Tray System		MCO-35ST-PW		
Double Stacking Bracket*		MCO-170PS-PW		
Stacking Plate*		MCO-230SB-PW		
Roller Base		MCO-230RB-PW		
Optional communication systems⁵⁾				
Analogue interface (4-20mA)		MCO-420MA-PW		

Appearance and specifications are subject to change without notice.

¹⁾ Exterior dimensions of main cabinet only, excluding handle and other external projections

²⁾ Ambient temp 23°C, setting 37°C, CO₂ 5%, no load

³⁾ Nominal value

⁴⁾ MCO-230AIC series requires MCO-170HB-PE, MCO-170EL-PW, MCO-HP-PW and SafeCell UV option for H₂O₂ decontamination

⁵⁾ MCO-230AIC series can only be fitted with one communications interface.

⁴⁾ Cleanroom classification in accordance with ISO 14644-1 - Part 14: Assessment of suitability for use of equipment by airborne particle concentration.

* If stacking two incubators, make sure the double-stacking dedicated securing hardware and spacer are used.
** These models are supplied as MCO-230AIC-PE with required options installed.