

**Notes:**

1. Visible outer surface should meet Ra 3.2 (VDI 3400 ref.30)
2. Whole inner surface should meet max. Ra 0.35 for efficient demolding
3. Sealing surfaces should meet a high polished surface
4. No overhang allowed at any point along the parting line.  
A flush to 0.13mm max step is allowable on one side only.
5. The outer surface should be smooth and free from any optical defects.
6. The injection point should not stand over and should be free from angel hairs.
7. min. draft angles 0,5°

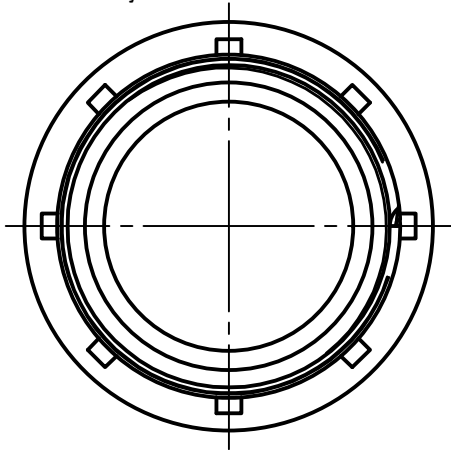

Schraubverschlusskappe GL 45  
mit Loch  $\varnothing 34,45$   
Art.-Nr. 29 239 28 17

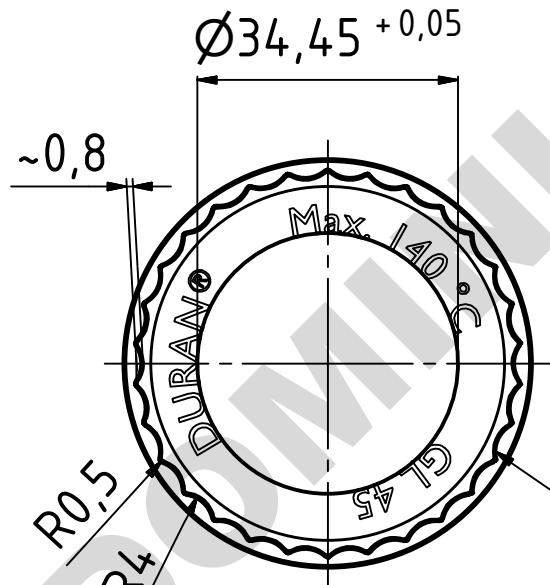
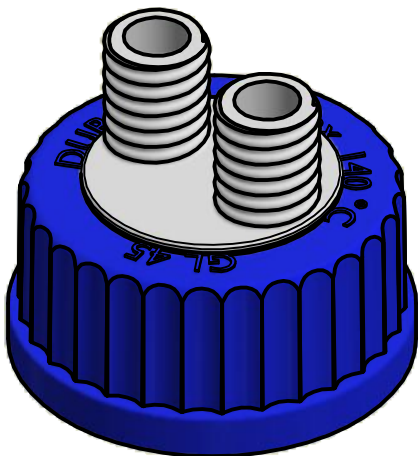
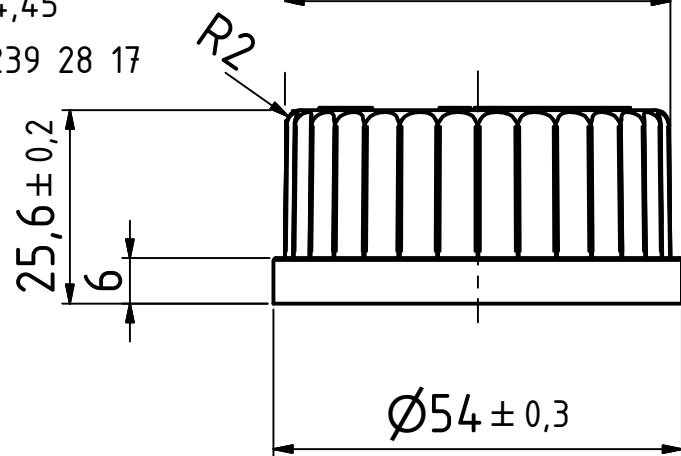

Verteilergewinde DIN 168-GL 14x2,5, 6 Umdrehungen  
Kappengewinde DIN 168-GL 45x4, 3 Umdrehungen

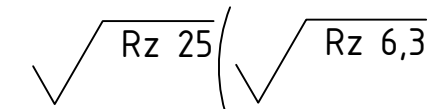
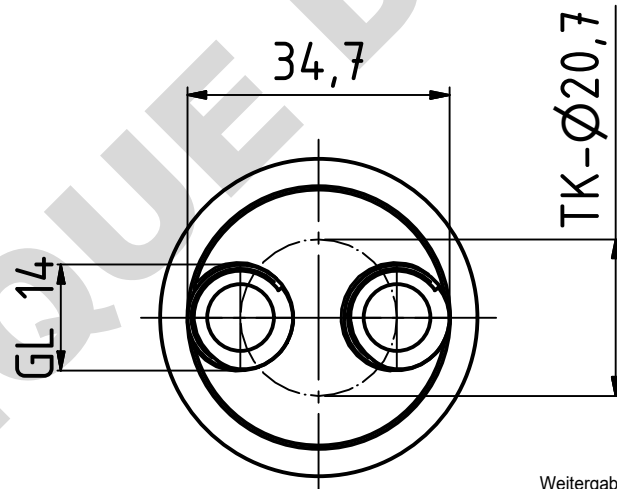
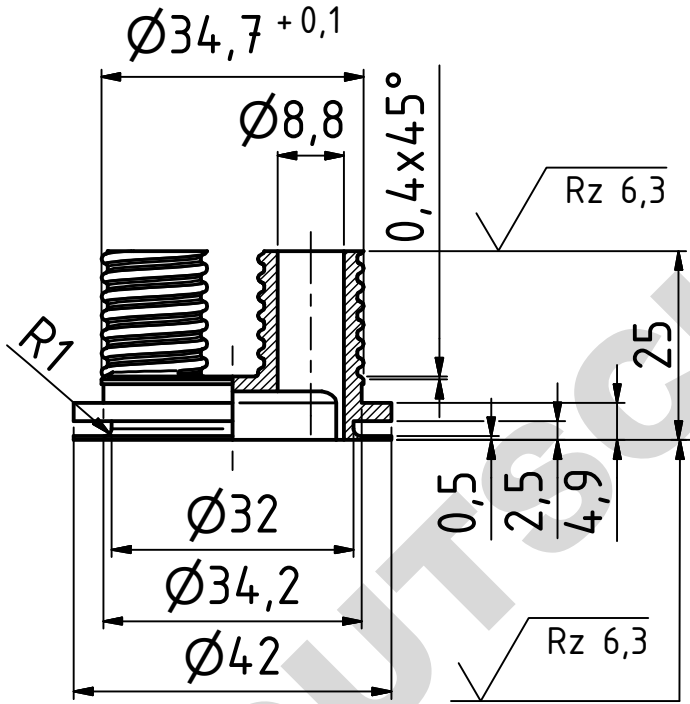

Anzahl Rippen 40

Weitergabe sowie Vervielfältigung dieses Dokuments, Verwertung und Mitteilung seines Inhalts sind verboten, soweit nicht ausdrücklich gestattet. Zuwiderhandlungen verpflichten zu Schadenersatz. Alle Rechte für den Fall der Patent-, Gebrauchsmuster- oder Geschmacksmustereintragung vorbehalten.  
The reproduction, distribution and utilization of this document as well as the communication of its contents to others without express authorization is prohibited. Offenders will be held liable for the payment of damages. All rights reserved in the event of the grant of a patent, utility model or design.

**Zusammenbau**

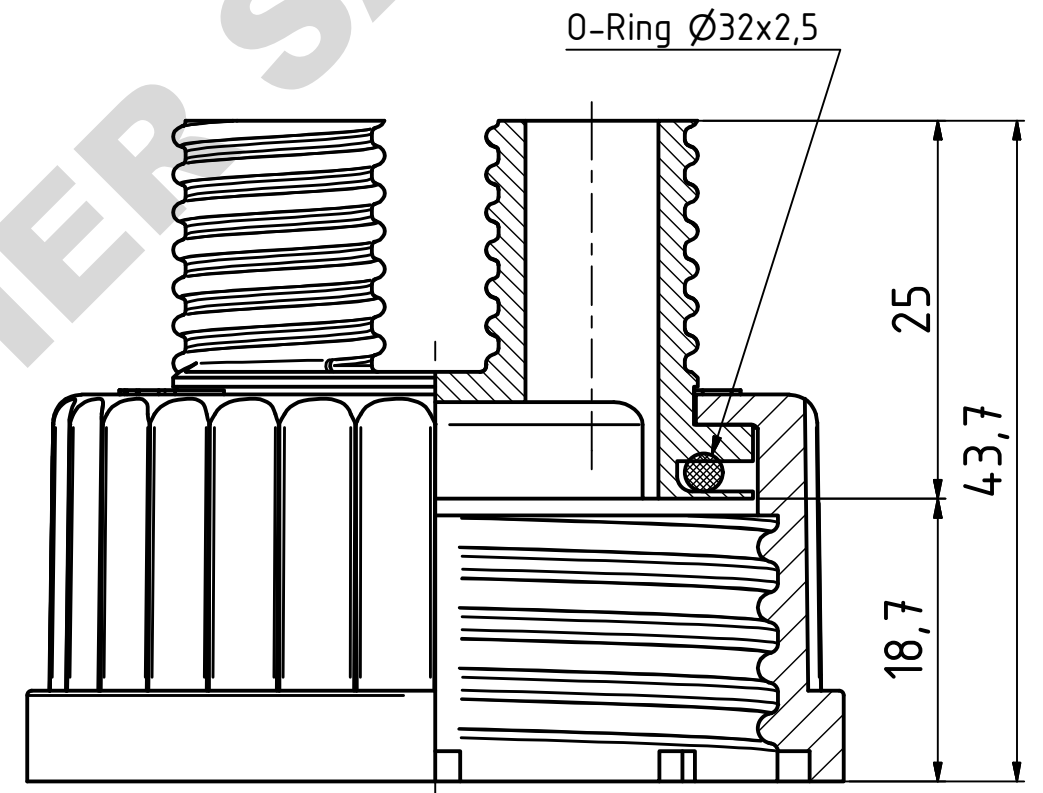

D	Change of logo to DURAN	10-JAN-18	Schneider
C	GL 14: $\varnothing 8,8$ war $\varnothing 8,3$ , höhe 2-fach=45mm	15-JUN-11	Wdf
B	Höhe war 25,3 $\pm 0,3$ , oberhalb Hut-Kragen war $\varnothing 52 \pm 0,2$	23-MAR-10	Wdf
A	Komplettiert	17-JAN-06	Wdf
Index	Aenderung / changes	Datum / date	Name
zul. Abweichung allowed dev.	Werkstoff / material	Stück quantity	Gewicht weight
Oberfläche surface	Benennung / title	Pos. position	
bearb. drawn	Datum / date	Name	
geprüft checked	10.01.2018	Schneider	
Schraubverschluss GL 45 mit zwei Ports GL 14		Maßstab scale	
Art.-Nr. 112 97 50		2 : 1	
Form-Nr. mould number		A3	
0668124-GZA-0GL45		Revision Blatt/sheet	
D		1 / 1	
DURAN Produktions GmbH & Co. KG www.DWK-LifeSciences.com		Ers. / repl.f.: 0668124-GZA-0GL45-C Ers. / repl.d.: Schutzvermerk ISO 16016 beachten / Refer to protection notice ISO 16016	
		INV	