

# Cole-Parmer®

## CB-200 Series Cooling Unit

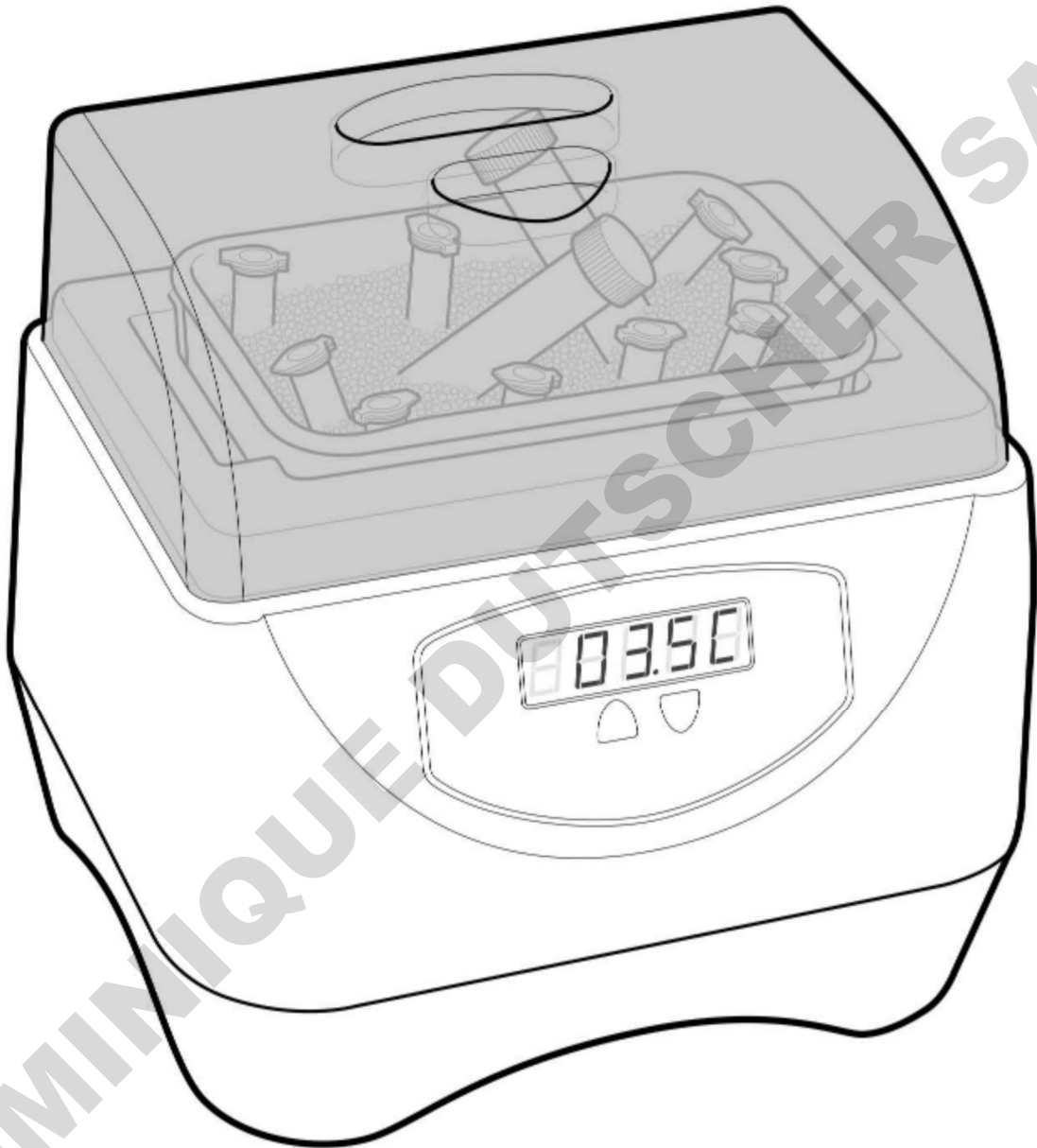

Instruction Manual

6106329 Version 3.1

**Cole-Parmer®**  
essentials

**DOMINIQUE DUTSCHER SAS**

---

## CONTENTS

	PAGE
<b>INTRODUCTION</b>	<b>2</b>
<b>BEFORE USE</b>	<b>3</b>
Unpacking	5
<b>SAFETY AND INSTALLATION</b>	<b>4</b>
<b>SÉCURITÉ ET CONSIGNES D'INSTALLATION</b>	<b>6</b>
<b>SICHERHEITS- UND INSTALLATIONSINFORMATIONEN</b>	<b>8</b>
<b>INFORMAZIONI SULLA SICUREZZA E L'INSTALLAZIONE</b>	<b>10</b>
<b>INFORMACIÓN DE SEGURIDAD E INSTALACIÓN</b>	<b>12</b>
<b>CONTACT INFORMATION</b>	<b>14</b>
<b>SPECIFICATION</b>	<b>15</b>
<b>OPERATION</b>	<b>16</b>
Installation	16
Power up Screen	16
Setting the Operating Temperature	17
Changing the Temperature	18
After Use	18
User Maintenance	18
<b>FAQS</b>	<b>19</b>
<b>ADDITIONAL INFORMATION</b>	<b>19</b>
Fault Finding	19
Fuses	20
Insulation Tests	20
<b>REPLACEMENT PARTS</b>	<b>20</b>

---

## INTRODUCTION

The CB-200D-IB is a Peltier controlled cooling device ideal for incubating any number or size of sample tubes at sub-ambient temperatures for as long as required. It is an excellent alternative to wet ice buckets which can be messy, inconvenient and lead to sample loss or contamination.

The removable bucket that sits inside the unit is filled with ceramic-coated beads that both maintain the user-set temperature and support the sample vessels. The ceramic beads are chemically resistant and if required, can be autoclaved at temperatures up to 134°C.

The temperature range of the CB-200D-IB (0 to 40°C) means that it is also suitable for other applications such as ligation and enzyme reactions where a constant temperature close to ambient temperatures is required. The unit is supplied with a dark plastic lid which maintains the cooled environment and helps to protect light-sensitive reagents.

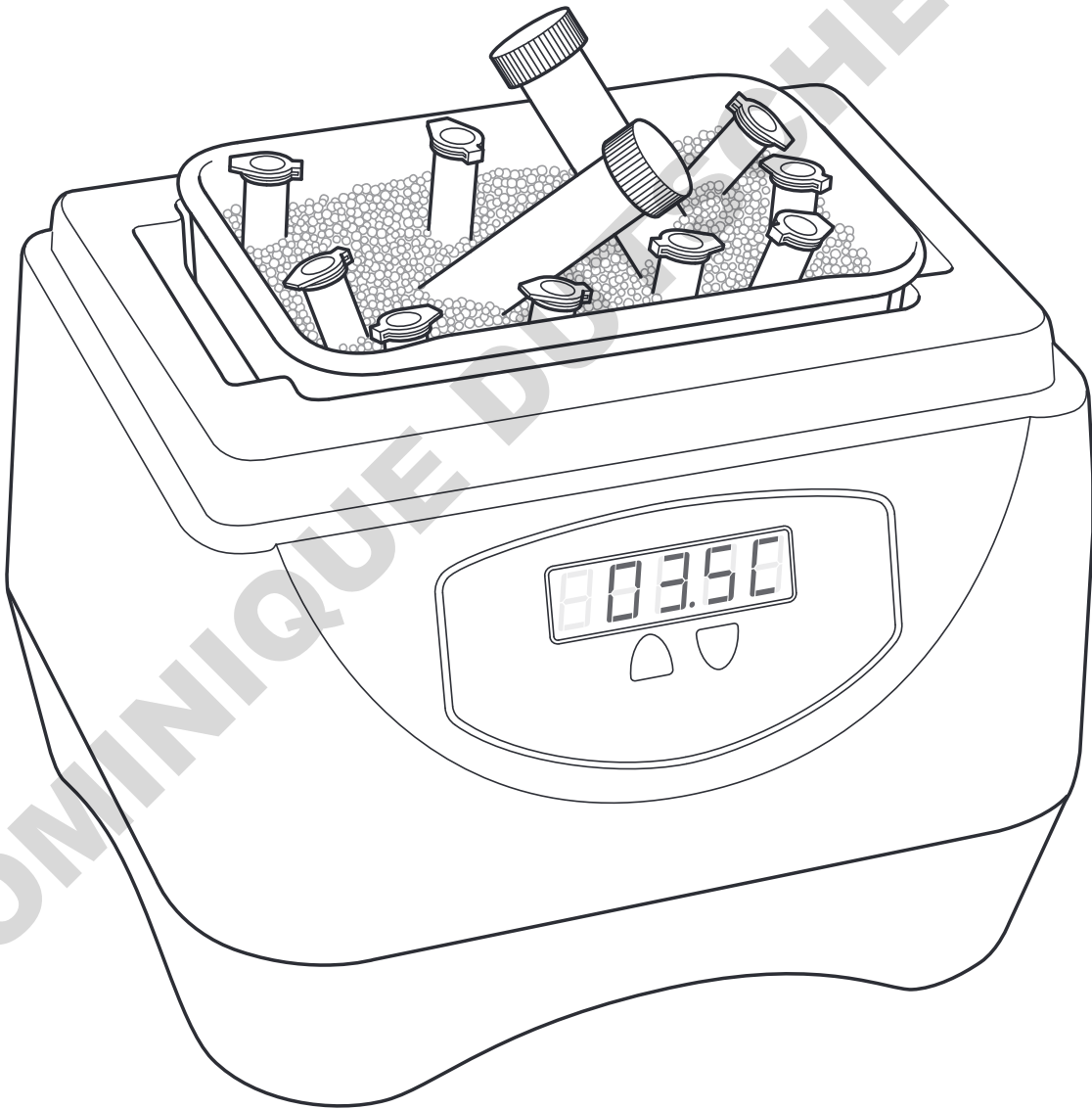

---

## BEFORE USE

Before using the CB-200D-IB please make sure you have read this manual carefully. If there is any doubt relating to the proper use of this equipment, the staff at Antylia Scientific or your supplier will be happy to assist you.

### UNPACKING

When unpacking the unit please ensure that the following have been removed from the packaging:

- CB-200D-IB
- Aluminium bucket
- Bag of ceramic-coated beads
- Mains cables (UK, EU and US)
- Operator's manual

The user is advised to keep the original packaging in case the instrument ever needs to be returned for service or repair. Antylia Scientific accepts no responsibility for damage incurred unless the unit is correctly packed and transported in its original packaging.

---

## SAFETY AND INSTALLATION

Please read all the information in this manual before using the CB-200D-IB.

### WARNING

Contact with low-temperature objects may cause cold burns. Users should be aware of the following potential hazards:

- USE CARE AND WEAR PROTECTIVE GLOVES TO PROTECT HANDS
- DO NOT place any liquid directly into the instrument.
- Do not position the unit such that it is difficult to disconnect it from the mains by removing the mains cable from the socket at the back.

### OPERATOR SAFETY

All operators of Cole-Parmer equipment must have available the relevant literature needed to ensure their safety. It is important that only suitably trained personnel operate this equipment, in accordance with the instructions contained in this manual and with general safety standards and procedures. If the equipment is used in a manner not specified by Antylia Scientific the protection provided by the equipment to the operator may be impaired.

All Cole-Parmer instruments are designed to conform to international safety requirements and are fitted with an over-temperature cut-out. If a safety problem should be encountered, switch off the unit at the mains socket and remove the plug from the electricity supply.

If the equipment is not used in the manner described in this manual and with accessories other than those recommended by Antylia Scientific, the protection provided may be impaired.

### INSTALLATION

The instrument should be carried using both hands. Never move or carry the instrument when in use or connected to the mains electricity supply.

1. All Cole-Parmer instruments are supplied with a power cable; this may be integral or plug-in.

2.  Before connecting the instrument to the mains electricity supply, check the voltage against the rating plate (located on the back of the unit). **Please note that the unit must be earthed to ensure proper electrical safety.** Connect the mains cable to a suitable plug according to the table below.

Connection	220/240V, 50/60Hz Supply	110V/120V Supply, 50/60Hz
Live	Brown	Black
Neutral	Blue	White
Earth	Green/yellow	Green

3. UK ONLY: The fused plug supplied with the mains cable is fitted with a 10 amp fuse to protect the instrument and the operator.

4. The units are rated to operate at 100-230V, 50/60Hz.

5. Place the unit on a suitable flat bench or in a fume cupboard if required, ensuring that the air vents on the rear and underside are free from obstruction.

---

6. Plug the mains cable into the socket on the back of the instrument.

7. Switch on the instrument. Symbols on or near the power switch of the unit have the following meanings:

- I Mains Switch On
- O Mains Switch Off

### REPLACEMENT CABLE

Should the mains lead need replacement, a cable of 1mm<sup>2</sup> of harmonized code H05VV-F connected to an IEC320 plug should be used. **IF IN DOUBT CONSULT A QUALIFIED ELECTRICIAN.**

### ENVIRONMENTAL CONDITIONS

The CB-200D-IB is designed to operate under the following conditions:

- Indoor use
- Ambient temperature range +5°C to +40°C
- Altitude to 2000m
- Relative humidity not exceeding 80%
- Mains supply fluctuations not exceeding 10%
- Over voltage category II IEC 60364-4-443
- Pollution degree 2

**Note:** The control specifications are quoted at an ambient temperature of 20°C. The specification may deteriorate outside an ambient temperature of between 10°C and 30°C.

The instrument has been tested for radio frequency interference and is certified under EN61326

## SÉCURITÉ ET CONSIGNES D'INSTALLATION

Veillez lire attentivement toutes les instructions de ce document avant d'utiliser le CB-200D-IB.

### AVERTISSEMENT

Le contact avec les objets à basse température peut causer les brûlures froides. Les utilisateurs devraient se rendre compte des risques suivants:

- PROCEDER AVEC PRUDENCE ET PORTER DES GANTS POUR SE PROTEGER LES MAINS
- NE PAS verser de liquides directement dans l'appareil.

### SÉCURITÉ DE L'OPÉRATEUR

Tous les utilisateurs de produits Cole-Parmer doivent avoir pris connaissance des consignes et instructions nécessaires à la garantie de leur sécurité. Important: cet appareil doit impérativement être manipulé par un personnel qualifié et être utilisé selon les instructions données dans ce document, en accord avec les normes et procédures de sécurité générales. Dans le cas où cet appareil ne serait pas utilisé selon les consignes précisées par Antylia Scientific, la protection pour l'utilisateur ne serait alors plus garantie.

Tous les appareils Antylia Scientific sont conçus pour répondre aux normes de sécurité internationales et sont dotés d'un coupe-circuit en cas de surchauffe. En cas de problème de sécurité, couper l'alimentation électrique au niveau de la prise murale et enlevez la prise connectée à l'appareil.

### INSTALLATION

Porter l'appareil à deux mains. Ne jamais déplacer ou transporter l'appareil lorsqu'il est en fonctionnement ou branché à l'alimentation électrique.

1. Tous les appareils Cole-Parmer sont livrés avec un câble d'alimentation, qui peut être intégré à l'appareil ou à raccorder.
2.  Avant de raccorder l'appareil à l'alimentation électrique sur secteur, vérifier la tension requise indiquée sur la plaque d'identification (située au dos de l'appareil). Il est important que l'appareil soit relié à la terre pour assurer la protection électrique requise. Brancher le câble secteur sur une prise appropriée, voir tableau ci-après.

Connexion	Alimentation 220/240V, 50/60Hz	Alimentation 110V/120V, 50/60Hz
Phase	Marron	Noir
Neutre	Bleu	Blanc
Terre	Vert/jaune	Vert

4. ROYAUME-UNI SEULEMENT: La prise avec fusible intégré fournie avec le câble secteur est munie d'un fusible 5 A destiné à protéger l'appareil et l'utilisateur.

5. Les unités sont évaluées pour fonctionner à 100-230V, 50/60Hz.



- 
6. Placez l'unité sur un banc plat approprié ou dans un compartiment de vapeur s'il y a lieu, en s'assurant que les événements sur l'arrière et le dessous sont exempts de l'obstruction.
  7. Raccorder le câble d'alimentation à la prise située à l'arrière de l'appareil.
  8. Allumer l'appareil. Les symboles situés sur ou à côté de l'interrupteur de l'appareil ont la signification suivante :

- I Interrupteur secteur en position Marche
- O Interrupteur secteur en position Arrêt

### **CÂBLE DE RECHANGE**

S'il s'avère nécessaire de remplacer le cordon d'alimentation, utiliser un câble de 1 mm<sup>2</sup> conforme à la norme H05VV-F relié à une prise EC320.

### **EN CAS DE DOUTE, CONSULTER UN ELECTRICIEN QUALIFIE.**

### **CONDITIONS ENVIRONNEMENTALES**

Le CB-200D-IB est conçu pour fonctionner dans les conditions suivantes:

- Pour un usage intérieur seulement
- Température ambiante +5°C à +40°C
- Altitude inférieure à 2000m
- Humidité relative ne dépassant pas 80%
- Fluctuations de l'alimentation n'excédant pas 10% de la valeur nominale
- Catégorie II IEC 60364-4-443 de surtension
- Degré de pollution 2

**Remarque:** Les paramètres sont indiqués pour une température ambiante de 20°C. Ces caractéristiques peuvent se détériorer en dehors d'une température ambiante de 10 à 30°C.

L'appareil a été testé en matière de radiofréquences et est certifié selon la norme EN61326

## SICHERHEITS- UND INSTALLATIONSINFORMATIONEN

Lesen Sie diese Anleitung vor Verwendung des CB-200D-IB bitte sorgfältig durch.

### ACHTUNG

Kontakt mit niedrig temperatur gegenständen kann kalte Brände verursachen. Benutzer sollten die folgenden möglichen Gefahren berücksichtigen:

- UMSICHTIG VORGEHEN UND SCHUTZHANDSCHUHE TRAGEN
- Flüssigkeiten NICHT direkt auf das Gerät auftragen.

### SICHERHEIT DES BEDIENPERSONALS

Alle Benutzer von Techne Geräten müssen Zugang zu der entsprechenden Literatur haben, um ihre Sicherheit zu gewähren. Es ist wichtig, daß diese Geräte nur von entsprechend geschultem Personal betrieben werden, das die in dieser Gebrauchsanweisung enthaltenen Maßnahmen und allgemeine Sicherheitsbestimmungen und -vorkehrungen beachtet. Wenn das Gerät anders eingesetzt wird als vom Hersteller empfohlen, kann dies die persönliche Sicherheit des Anwenders beeinträchtigen.

Die Geräte von Techne entsprechen den internationalen Sicherheitsbestimmungen und sind mit einem automatischen Übertemperaturabschalter ausgestattet. Wenn ein Sicherheitsproblem auftreten sollte, muß das Gerät ausgeschaltet und vom Stromnetz getrennt werden.

### INBETRIEBNAHME

Das Gerät mit beiden Händen tragen. Das Gerät unter keinen Umständen transportieren, wenn es in Betrieb ist, oder während das Gerät noch am Netz angeschlossen ist.

1. Alle Geräte von Cole-Parmer werden mit einem Netzkabel geliefert, das entweder eingesteckt wird oder fest mit dem Gerät verbunden ist.
2.  Vor dem Anschluss bitte kontrollieren, ob die Stromversorgung den Angaben auf dem Typenschild (auf der Geräterückseite) entspricht. Um die elektrische Sicherheit zu gewährleisten, muss dieses Gerät geerdet werden. Schließen Sie das Netzkabel entsprechend der folgenden Tabelle an einen geeigneten Stecker an.

<b>Anschluss</b>	<b>220/240V, 50/60Hz</b>	<b>110V/120V, 50/60Hz</b>
Phase	Braun	Schwarz
Neutral	Blau	Weiß
Erde	Grün/Gelb	Grün

3. NUR FÜR GROSSBRITANNIEN: der mit dem Netzkabel gelieferte Sicherungsstecker enthält eine 5 Amp. Sicherung zum Schutz des Geräts und des Anwenders.
4. Die Maßeinheiten werden veranschlagen, um an 100-230V, 50/60Hz zu funktionieren.

---

5. Legen Sie die Maßeinheit auf eine verwendbare flache Bank oder in einen Dampfschrank wenn erforderlich und garantieren, dass die Luftentlüftungsöffnungen auf der Rückseite und der Unterseite vom Hindernis frei sind.

6. Stecken Sie das Netzkabel in die Buchse auf der Geräterückseite ein.

7. Schalten Sie das Gerät ein:

Netzschalter Ein

Netzschalter Aus

### ERSATZKABEL

Bei einem eventuellen Austausch des Netzkabels wird ein Kabel vom Typ H05VV-F mit 1 mm<sup>2</sup> Aderquerschnitt und Europastecker (IEC 320) benötigt. **IM ZWEIFELSFALL EINEN ELEKTROFACHMANN HINZUZIEHEN.**

### UMWELTBEDINGUNGEN

Der N° ICE ist für den Einsatz unter folgenden Bedingungen ausgelegt:

- Gebrauch in Innenräumen
- Umgebungstemperatur zwischen +5°C an +40°C
- Höhe: bis zu 2000 m
- Relative Feuchte nicht über 80%
- Netzspannungsschwankungen nicht über 10%
- Überspannungsklasse 2 IEC 60364-4-443
- Verschmutzungsgrad 2

**Hinweis:** Die Gerätespezifikationen beziehen sich auf eine Umgebungstemperatur von 20°C und können sich außerhalb des Bereichs 10°C bis 30°C verschlechtern.

Das Gerät wurde auf HF-Störeinflüsse geprüft und entspricht den EMV-Bedingungen nach EN61326.

## INFORMAZIONI SULLA SICUREZZA E L'INSTALLAZIONE

Leggere attentamente il presente manuale prima di usare il CB-200D-IB.

### AVVERTENZA

Il contatto con gli oggetti a bassa temperatura può causare le ustioni fredde. Gli utenti dovrebbero essere informati di seguenti rischi potenziali:

- PRESTARE ATTENZIONE ED INDOSSARE GUANTI PROTETTIVI PER LE MANI
- NON collocare alcun tipo di liquido direttamente nello strumento.

### SICUREZZA DELL'OPERATORE

Il personale che utilizza l'apparecchiatura Cole-Parmer deve avere a disposizione la documentazione necessaria al fine di assicurare la loro incolumità. È importante che solo personale adeguatamente addestrato utilizzi questo apparecchio, in conformità alle istruzioni contenute in questo manuale e nel rispetto delle normative e procedure generali di sicurezza. Se l'apparecchio è utilizzato in modo non specificato da Antylia Scientific, la protezione fornita dall'apparecchiatura all'utilizzatore potrebbe essere a rischio.

Tutte le unità Antylia Scientific sono state progettate in conformità ai requisiti internazionali di sicurezza e sono equipaggiate con un interruttore anti surriscaldamento. Se si dovesse verificare qualche problema di sicurezza, disconnettere l'apparecchio dalla rete.

### INSTALLAZIONE

Occorre trasportare lo strumento usando entrambe le mani. Non spostare né trasportare lo strumento quando è in funzione o collegato all'alimentazione elettrica di rete.

1. Tutti gli strumenti Techne sono forniti con un cavo di alimentazione; può essere integrale o plugin.

2.  Prima di collegare lo strumento all'alimentazione elettrica di rete, controllare la tensione confrontandola con la targhetta riportante i valori nominali (si trova sul retro dell'unità). Notare che al fine di garantire la corretta sicurezza elettrica, occorre che l'unità sia messa a terra. Collegare il cavo di rete ad una presa idonea secondo la tabella riportata alla pagina successiva.

Connessione	220/240V, Alimentazione 50/60Hz	Alimentazione 110V/120V, 50/60Hz
Sotto tensione	Marrone	Nero
Neutro	Blu	Bianco
Terra	Verde/giallo	Verde

3. SOLO REGNO UNITO: la spina con fusibile fornita con il cavo di rete è dotata di un fusibile da 5 Amp per proteggere lo strumento e l'utente.

4. Le unità sono stimate funzionare a 100-230V, 50/60Hz.

---

5. Disponga l'unità su un banco piano adatto o in un armadietto di vapore a richiesta, accertandosi che i cunicoli di ventilazione sulla parte posteriore e sul lato siano esenti dall'ostruzione.

6. Inserire il cavo di rete nella presa che si trova sul retro dello strumento.

7. Accendere lo strumento:

**I** Interruttore di rete Acceso

**O** Interruttore di rete Spento

### CAVO DI RICAMBIO

Qualora occorra sostituire il cavo di rete, si dovrà utilizzare un cavo di 1mm<sup>2</sup> codice armonizzato H05VV-F collegato ad una spina IEC 320. IN CASO DI DUBBIO, RIVOLGERSI A UN ELETTRICISTA QUALIFICATO.

### CONDIZIONI AMBIENTALI

Il CB-200D-IB è stato progettato per funzionare nelle seguenti condizioni:

- uso interno
- range di temperatura ambiente da +5°C a +40°C
- altitudine massima 2000 m.
- umidità relativa non superiore all'80%
- oscillazione dell'alimentazione di rete non superiore al 10%
- categoria di sovratensione II IEC 60364-4-443
- grado di inquinamento 2

**Nota:** le specifiche di controllo sono indicate ad una temperatura ambiente di 20°C. Le specifiche potrebbero peggiorare fuori da una temperatura ambiente compresa tra 10°C e 30°C.

Lo strumento è stato collaudato per interferenze da radiofrequenze ed è certificato secondo la norma EN61326.

## INFORMACIÓN DE SEGURIDAD E INSTALACIÓN

Lea atentamente este manual antes de utilizar el CB-200D-IB.

### ADVERTENCIA

El contacto con los objetos a baja temperatura puede causar quemaduras frías. Los usuarios deben ser conscientes de los peligros potenciales siguientes:

- TENGA CUIDADO Y LLEVE GUANTES DE PROTECCIÓN PARA PROTEGERSE LAS MANOS
- NO coloque un líquido directamente en el instrumento.

### SEGURIDAD DEL OPERARIO

Todos los usuarios de equipos Cole-Parmer deben disponer de la información necesaria para asegurar su seguridad. De acuerdo con las instrucciones contenidas en este manual y con las normas y procedimientos generales de seguridad, es muy importante que sólo personal debidamente capacitado opere estos aparatos. De no ser así, la protección que el equipo proporciona al usuario puede verse reducida.

Todos los equipos Antylia Scientific han sido diseñados para cumplir con los requisitos internacionales de seguridad y traen incorporados un sistema de desconexión en caso de sobre temperatura. En caso de que surgiera un problema de seguridad, desconecte el equipo de la red.

### INSTALACIÓN

El esté conectado al suministro eléctrico principal. El instrumento se debe transportar con las dos manos. No mueva ni lleve el instrumento cuando se utilice.

1. Todos los instrumentos Cole-Parmer se suministran con un cable de alimentación, que puede ser integrado o 'enchufable'.
2.  Antes de conectar el instrumento al suministro eléctrico, compruebe que el voltaje con el indicado en la placa de régimen (situada en la parte trasera de la unidad). El instrumento debe disponer de una toma de tierra para garantizar la seguridad eléctrica adecuada. Conecte el cable de alimentación a un enchufe adecuado según la siguiente tabla.

Conexión	220/240V, 50/60Hz	110V/120V, 50/60Hz
Con corriente	Marrón	Negro
Neutro	Azul	Blanco
Toma de tierra	Verde/amarillo	Verde

3. SÓLO PARA EL REINO UNIDO: El enchufe suministrado con el cable de alimentación incluye un fusible de 5 amperios para ofrecer protección al instrumento y al usuario.
4. Las unidades se clasifican para funcionar en 100-230V, 50/60Hz.
5. Ponga la unidad en un banco plano conveniente o en un armario de humo si procede, asegurándose de que las salidas de aire en la parte posterior y el superficie inferior están libres de la obstrucción.

---

6. Conecte el cable de alimentación en el enchufe situado en la parte trasera del instrumento.

7. Encienda el instrumento:

- I Interruptor de alimentación encendido
- O Interruptor de alimentación apagado

### **CABLE DE REPUESTO**

Si es necesario sustituir el cable de alimentación, se debe utilizar un cable de 1mm<sup>2</sup> de código armonizado H05VV, conectado a un enchufe EC320. **EN CASO DE DUDA, PÓNGASE EN CONTACTO CON UN ELECTRICISTA.**

### **CONDICIONES AMBIENTALES**

El CB-200D-IB está diseñado para utilizarse en las condiciones siguientes:

- Uso en interior
- Intervalo de temperatura ambiente +5°C a +40°C
- Altitud: hasta 2000 m
- Humedad relativa no superior al 80%
- Fluctuaciones del suministro eléctrico no superiores al 10%
- Categoría de sobrevoltaje II IEC 60364-4-443
- Nivel de contaminación 2

**Nota:** Las especificaciones de control corresponden a una temperatura ambiental de 20°C. Las especificaciones pueden empeorar si se utiliza el instrumento fuera del intervalo de temperatura comprendido entre 10°C y 30°C.

Se han realizado pruebas para comprobar la interferencia de radiofrecuencia del instrumento, el cual cumple la normativa EN61326.

---

## SPECIFICATION

---

### Temperature

---

Temperature range	0.0 to 40.0°C
Temperature accuracy	+/-1°C
Temperature units	C or °F
Cooling technology	Peltier
Temperature display resolution	0.1°C
Temperature display	Orange LED, 5 digits

---

### Dimensions

---

Height	225mm
Width	240mm
Length	190mm
Weight*	4.5kg

\*Shipping weight includes bucket and ceramic beads

---

### Power

---

Power supply	100 to 230V, 50/60Hz, 75W
Fuse	Glass 5x20mm, T5A, 250V



## OPERATION

### INSTALLATION

See also the sections on Safety and Installation.

1. Place the unit on a suitable flat bench or in a fume cupboard if required, ensuring that the air vents on the rear and underside are free from obstruction.
2. Plug the mains cable into the socket on the back of the instrument.
3. Fill the aluminium bucket with the ceramic-coated beads and place the bucket inside the unit.
4. Connect to the mains electricity supply with the plug provided or one wired correctly for the supply. Switch the power ON from the switch located next to the mains input lead. The front display will then light up.

### POWER UP SCREEN

When first switched on, the display will show the text **No Ice** and then show the current temperature of the unit. The unit will then proceed to heat or cool to the set temperature.



### FRONT PANEL CONTROLS

The front panel consists of two buttons for setting the unit temperature and a 5 digit LED display.

#### The UP ARROW Button

When this button is pressed, the set temperature is increased.

#### The DOWN ARROW Button

When this button is pressed, the set temperature is decreased.

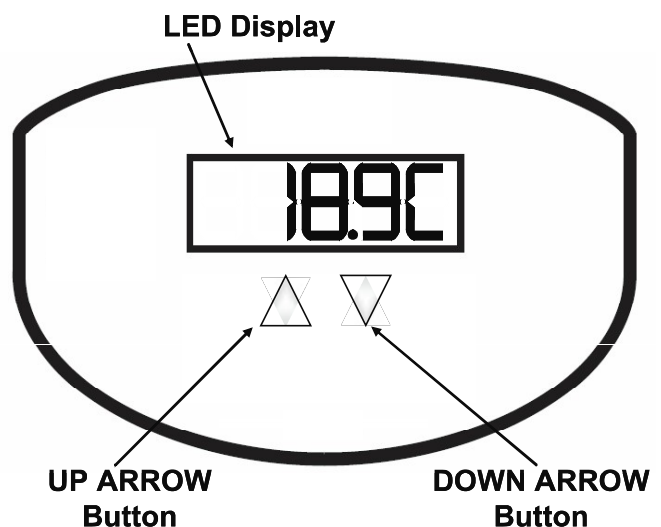

## SETTING THE OPERATING TEMPERATURE

1. To view the current set temperature, press either the UP or DOWN ARROW button. The set temperature will be displayed and is indicated by a small point in the top left hand corner of the display.
2. To **increase** the set temperature, press and hold the UP ARROW button. The set temperature will momentarily be displayed and then the temperature display will begin to increase. Continue to press the UP ARROW button until the new set temperature is reached then release the button. To fine tune the temperature settings, a single press of the UP or DOWN ARROW keys will increase or decrease the set temperature by 0.1°C.
3. To **decrease** the set temperature, press and hold the DOWN ARROW button. The set temperature will momentarily be displayed and then the temperature display will begin to decrease. Continue to press the DOWN ARROW button until the new set temperature is reached then release the button. To fine tune the temperature settings, a single press of the UP or DOWN ARROW buttons will increase or decrease the set temperature by 0.1°C.
4. Once the set temperature has been changed, the unit will heat or cool to the new set temperature.

**Note:** The ceramic beads will take some time to equilibrate to the set temperature; therefore it is recommended that the unit is set up in advance to allow time for the required temperature to be reached. To speed up cooling times, the bucket containing the ceramic beads may be stored in a refrigerator prior to use.

Set Point Indicator

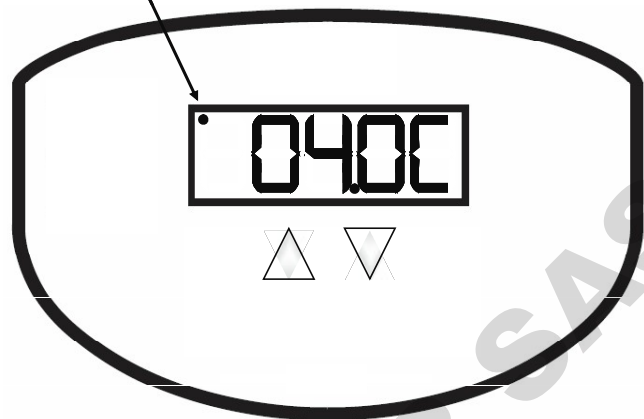

New Set Point Indicator

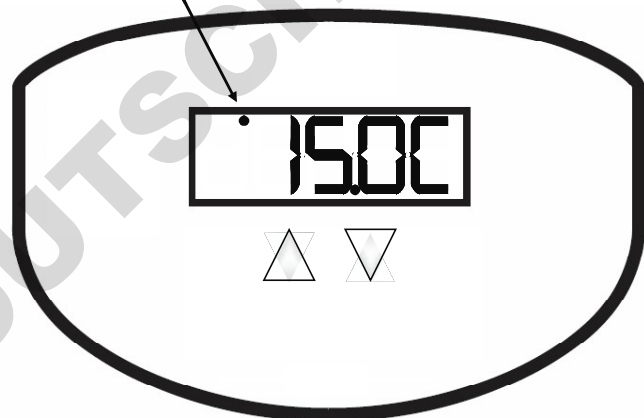

Changing the set temperature will cause the Set Point Indicator to move position while this is being carried out.

---

## CHANGING THE TEMPERATURE UNITS

The temperature of the display can be shown in either °C or °F.

1. To change the temperature units, first turn the power to the unit OFF.
2. Switch the power to the unit ON whilst holding down the UP ARROW button.
3. The temperature unit selection screen will then be displayed. Release the UP ARROW button and then press it again to toggle between °C and °F.

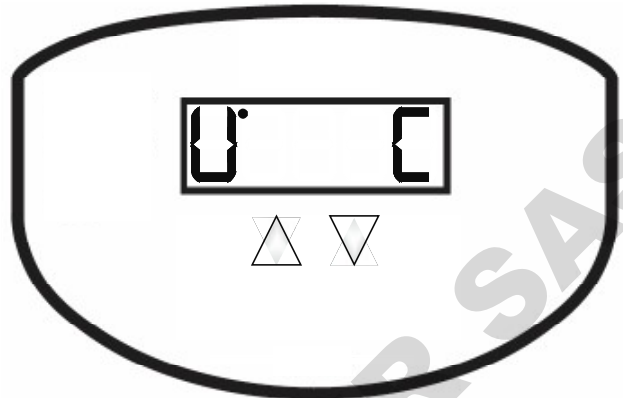

4. Once the required temperature unit has been selected, after a short time the unit will automatically show the current temperature in the selected units.

## AFTER USE

After cooling samples, the bucket and beads may be very cold. Allow to warm to ambient conditions before lifting from the unit or wear protective gloves. Avoid handling cold objects with wet hands.

## USER MAINTENANCE

Before cleaning the unit, disconnect it from the power supply. The outer case of the CB-200D-IB may be wiped clean with a damp cloth; ethanol, methanol or formaldehyde can also be used. No part of the case or cover should be immersed in the solvents. Do not use aggressive solvents such as acetone or abrasive cleaners.

Allow the unit to dry before using.

Before using any cleaning or decontamination method except those recommended here, the responsible person should check with Cole-Parmer that the proposed method will not damage the equipment.

---

## FAQ'S

Q1 How can I cool the beads more quickly?

A1 **If you intend to use the CB-200D-IB to keep samples cool, then the bucket and beads can be stored in a refrigerator and then inserted into the unit when required.**

Q2 Is it possible to sterilise the beads?

A2 **Yes. Place the beads in a suitable container and autoclave as you would for sterilising other equipment. The beads can be autoclaved at up to 134°C.**

If you require further technical or application assistance please contact Antylia Scientific at:

Antylia Scientific Ltd.  
Service Department,  
Beacon Road,  
Stone,  
Staffordshire,  
ST15 0SA,  
Email: [cpSERVICE@antylia.com](mailto:cpSERVICE@antylia.com)  
Phone: +44 (0)1785 810475

If you require further technical or application assistance please contact:

Email: [cpTECHSUPPORT@antylia.com](mailto:cpTECHSUPPORT@antylia.com)  
Phone: +44 (0)1785 810433

We are continually striving to improve our products and software. If you have any comments and suggestions on how we can do things better please send them to us at: [cpTECHSUPPORT@antylia.com](mailto:cpTECHSUPPORT@antylia.com)

## ADDITIONAL INFORMATION

Note that **this equipment should only be dismantled by properly trained personnel**. Removing the outer cover exposes potentially lethal mains voltages. There are no user serviceable parts within this equipment.

### FAULT FINDING

Should you have any problems with your CB-200D-IB which cannot be easily remedied, you should contact your supplier and return the unit if necessary. Please include details of the fault observed and remember to return the unit in its original packing. Antylia Scientific accepts no responsibility for damage to units which are not properly packed for shipping: if in doubt, contact your supplier, giving the full serial number of the unit.

---

## FUSES

If the display on the front panel is not lit, one of the two fuses may have blown. Check that there is no external cause, such as a faulty plug or lead. Check both fuses and replace the faulty fuse with a new one of the correct value (fuse values are given on the label next to the power inlet). Note that **fuses should only be replaced by a qualified electrician.**

The holder for the two fuses is built into the mains input socket. First remove the power cable and then gently prise the fuse drawer open with a flat-bladed screwdriver or similar tool. Each fuse can be removed by using the screwdriver as a lever.

Exchange the faulty fuse in the fuse holder for a working fuse of the correct value. Finally, replace the fuse drawer in the fuse compartment and push the drawer shut. Fuses which blow repeatedly indicate a serious fault and you should return the unit to your supplier for repair.

## INSULATION TESTING

This equipment is fitted with RFI suppression circuitry. Any check of the electrical insulation by means of high voltage dielectric testing (for example as in BS EN 61010-1) must be carried out using only a DC voltage.

This unit contains semiconductor components which may be damaged by electric field effects.

## REPLACEMENT PARTS

The following replacement parts can be obtained from Antylia Scientific or your Cole-Parmer dealer:

Product Code	Description
FICEBUCKET	CB-200D-IB spare bucket
FTCOOLBE	CB-200D-IB replacement ceramic beads
HH179(S)	UK 230V mains lead with plug
HH180(S)	European mains lead with plug
HFCABLEUS	US mains lead with plug
700738(s)	Fuse Type T5A, 250V (5A)

**DOMINIQUE DUTSCHER SAS**



This product meets the applicable CE Directives and UKCA Legislation for radio frequency interference and may be expected not to interfere with, or be affected by, other equipment with similar qualifications. We cannot be sure that other equipment used in its vicinity will meet these standards and so we cannot guarantee

that interference will not occur in practise. Where there is a possibility that injury, damage or loss might occur if equipment malfunctions due to radio frequency interference, or for general advise before use, contact the manufacturer.

Declaration of Conformity is available to view online at [www.coleparmer.com](http://www.coleparmer.com)

**EU Representative address**

Antylia Scientific GmbH  
Futtererstraße 16  
97877 Wertheim  
Deutschland  
Tel: +49 9377 9203-0  
Email: [sales@coleparmer.de](mailto:sales@coleparmer.de)

**UK Representative address**

Antylia Scientific  
9 Orion Court  
Ambuscade Road  
Colmworth Business Park  
St. Neots  
PE19 8YX  
United Kingdom  
Tel: +44 (0) 1480 277339  
Email: [enquiries@antylia.com](mailto:enquiries@antylia.com)

# Ordering Information

Order No.	Series	Model	Legacy SKU
24120-00	CB-200	CB-200D-IB	FNOICE

Warranty Registration



**UK**

T: +44 (0) 1480 272279  
E: uk.sales@antylia.com  
W: coleparmer.co.uk

**Germany**

T: +49 (0) 9377 92030  
E: de.sales@antylia.com  
W: coleparmer.de

**France**

T: +33 (0) 1486 37800  
E: fr.sales@antylia.com  
W: coleparmer.fr

**Italy**

T: +39 (0) 284349215  
E: it.sales@antylia.com  
W: coleparmer.it

**India**

T: +91 22 61394444  
E: info@antylia.com  
W: coleparmer.in

**China**

T: +1 847 549 7600  
E: sales@antylia.com  
W: coleparmer.com

**USA**

T: +1 847 549 7600  
E: sales@antylia.com  
W: coleparmer.com

**Canada**

T: +514 355 6100  
E: info.@antylia.ca  
W: coleparmer.it

**Other**

T: +1 847 549 7600

**Cole-Parmer®**  
essentials

Antylia Scientific Ltd  
Beacon Road,  
Stone,  
Staffordshire,  
ST15 0SA  
United Kingdom

