



WSG60

3-Cup Electric Power Grinder – Wet/Dry



MAIN FEATURES

- Features the power and finesse needed to create perfect textures and blends of hard spices
- Powerful, 1 HP commercial motor – 20,000 RPM
- Sturdy, die-cast motor housing and base
- Upper assembly has an interlocking safety cover
- Comes with two 3-cup stainless steel grinding bowls and lids
- Continuous ON function for hands-free operation
- PULSE function lets you fine-tune your grind to create a precise consistency
- Sealed, clear-view lid allows for liquid processing up to 1.5 cups to make pastes, dressings, sauces, creams and more
- Limited 1 Year Warranty

ELECTRICAL

Voltage: 120

Frequency: 60Hz

Watts: 750

Amps: 6.25

Plug Type: NEMA 5-15P 

Cord Length: 5 feet



SALES FEATURES

The 3-cup capacity Waring® WSG60 Wet/Dry Power Grinder is perfect for peppercorns, cinnamon, nuts, garlic, herbs, and other dry and wet blends. Includes two fully removable and dishwasher-safe, stainless steel grinding bowls with convenient storage lids. Sealed clear-view operating lid allows for liquid processing up to 1.5 cups to make pastes, dressings, sauces, creams and more.



@waringcommercial

©2019 Waring Commercial
314 Ella T. Grasso Avenue, Torrington, CT 06790
Tel. 800-492-7464 • Fax 860-496-9008

waringcommercialproducts.com

3-Cup Electric Power Grinder – Wet/Dry

WSG60



PARTS & ACCESSORIES



CAC128 Stainless Steel Bowl with Lid

DIMENSIONS

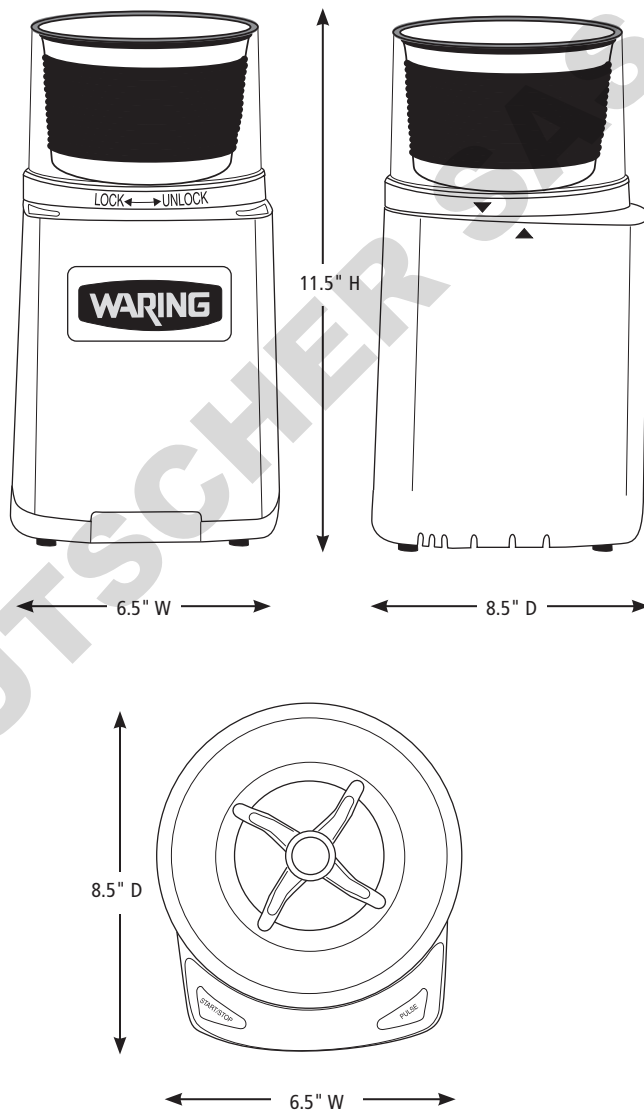

Out of Box Weight: 7.2 lb.

ORDERING INFORMATION	#STD. PKG.	GIFTBOX WEIGHT	CUBIC FEET	BOX DIMENSIONS D X W X H	UPC	CASE PKG.	MC WEIGHT	MC DIMENSIONS D X W X H	MBC
WSG60 – 3-Cup Electric Power Grinder – Wet/Dry	1	9.8	.745	8.65" x 14.32" x 10.5"	040072026140	2	19.7	17.7" x 15" x 11.5"	10040072026147



@waringcommercial

©2019 Waring Commercial
314 Ella T. Grasso Avenue, Torrington, CT 06790
Tel. 800-492-7464 • Fax 860-496-9008

waringcommercialproducts.com

19WC061076 / REV 04/19