

**⚠ CAUTION! Do not subject the MegaMag Genie® to excessive shock.**  
Dropping the unit, or otherwise subjecting it to unnecessary shock (ie: using excessive force to place vessels on the unit) may crack the case and lead to unsafe conditions.

**⚠ CAUTION! Failure to follow operating instructions can compromise the user's safety.**

#### Care and Handling

The **MegaMag Genie** should be given the care normally required for any electrical appliance. Avoid wetting or unnecessary exposure to fumes. The finish can be washed with a damp cloth (after unplugging) and soap or mild detergents, using a cloth or sponge. Keep the unit clean by immediately blotting any spills.

**⚠ CAUTION! Unplug from power before cleaning. Do not immerse.**

**⚠ CAUTION! Do not use MegaMag Genie in hazardous atmospheres or with hazardous materials.**

**⚠ CAUTION! Do not use MegaMag Genie in applications such as mixing of flammable materials or where the transfer of mechanical energy to glass apparatus could lead to breakage.**

#### TECHNICAL SPECIFICATIONS

The MegaMag Genie Magnetic Stirrer is classified as "Installation Category 2"  
Environmental: 0°C – 38°C (32°F-100°F), 95% Humidity max.

MODEL	POWER REQUIRED	AMPS
SI-2236	120V	0.65
SI-3236	120V	0.65
SI-2246	230V	0.5
SI-3246	230V	0.5
SI-2286	100V	1.0
SI-3286	100V	1.0

Weight: 3.0 Kg (35 lbs.)

Maximum Load: 38 liters

Dimensions (DxWxH): 317x315x137mm (12.5x12.4x5.4in)

# MegaMag Genie®

## Large Volume Magnetic Stirrer

### Operating Instructions

Analog Models SI-2236 through SI-2296  
Digital Models SI-3236 through SI-3296



80 Orville Drive, Suite 102, Bohemia, NY 11716 U.S.A.  
Phone: (631) 567-4700 • Fax: (631) 567-5896 Toll Free: 888-850-6208  
Customer Service: [custsvc@scientificindustries.com](mailto:custsvc@scientificindustries.com)  
[www.scientificindustries.com](http://www.scientificindustries.com)

The **MegaMag Genie®** is a large volume magnetic stirrer offered in Digital models with speed/time control and Analog models with speed control.

The **MegaMag Genie** is designed to safely and reliably mix liquid volumes up to 38 liters (10 gallons) using magnetic stirring bars. The rugged housing is made with an engineering grade thermoplastic resin and can support up to 85 pounds. A timing belt driven pulley rotates a powerful rare earth magnet that couples with the stirring bar (3-inch stir bars are recommended for most applications). Mixing speeds are variable up to 250-1300 RPM (10 RPM increments for digital version) to facilitate gentle stirring up to full vortex mixing. The digital models have an opto-electronic software driven “ramp to speed” feature that ensures maximum coupling between drive magnet and stir bar (analog models require manual speed ramping). The enclosure is air cooled to prevent heat transfer to mixing media. Digital models have large LED’s for displaying speed and time (0-99 min) or continuous.

## OPERATING INSTRUCTIONS

We recommend you retain the original packaging for 90 days in case you need to return the product for any reason to your distributor or Scientific Industries.

1.0 - Plug the line cord into a properly grounded electrical outlet.  
**(120 VAC for the SI-2236 and SI-3236 models; 230/240 VAC for the SI-2246 through SI-2276, SI-2296 and SI-3246 through SI-3276, SI-3296 models; 100 VAC for the SI-2286 and SI-3286 models).** Illuminated ON/OFF switch (analog models) and illuminated numbers in the **TIME** and **SPEED** windows (digital models) indicate that the unit is ON and ready for use.

### 2.0 - MegaMag Genie Digital Models

Allows for unattended operation that is timed from 1 to 99 minutes.

Press the **UP/DOWN** arrow buttons beneath the **TIME** window to set the desired stirring time. Press the **UP/DOWN** arrows beneath the **SPEED** window to set the desired stirring speed. Press the **START/STOP** button to begin the stirring action. The stirrer will ramp up to the desired speed and run until the set time has elapsed. To stop the cycle before the set time has elapsed, press the **START/STOP** button. To initiate a new timed cycle, press the **START/STOP** button again.

#### 2.1 - “SLEEP” Mode

The stirrer will automatically go into a “SLEEP” mode if the mixer is plugged in but not used for 10 minutes. The **TIME** and **SPEED** illuminated displays will go blank. Press the **START/STOP** button to “WAKE UP” the mixer.

*Note: The speed control can be adjusted up or down during the mixing cycle, however, the TIME can only be adjusted before the cycle begins.*

### 3.0 - MegaMag Genie Analog Models

Allows for operation that will continue indefinitely until the unit is turned off. Press the ON/OFF switch into the ON position. Adjust the SPEED potentiometer to the desired stirring speed. To ensure strong coupling between drive magnet and stir bar, it is recommended to manually ramp to maximum speed.

**PARTS ASSEMBLY LIST:** To order parts for the **MegaMag Genie®** - Contact your local distributor or visit [www.scientificindustries.com](http://www.scientificindustries.com). Please specify Part No, quantity and electric voltage.

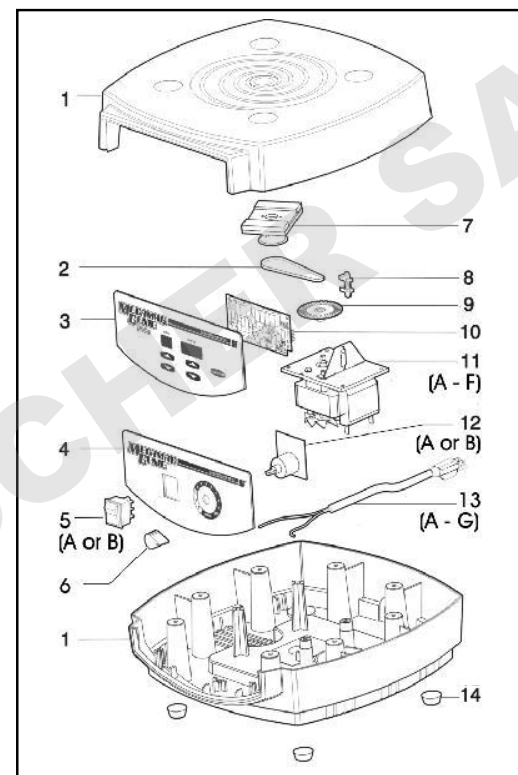

Indicator No.	PART No.	DESCRIPTION
1	PP-2236-400	Housing, Top and Bottom Cover
2	HWP0058	Belt
3	EL-2236-575	Key Pad Assembly, Digital
4	0M-2236-900	Name Plate Assembly, Analog
5A	ESP0001	Rocker Switch, Red, 230V
5B	ESP0002	Rocker Switch, Green, 230V
6	OK-0236-209	Knob, Push-on
7	OK-2236-901	Magnet Assembly
8	EC-A236-525	Optical Switch
9	OK-2236-902	Optical Disc Assembly
10	EB-3236-500	Digital Timer Board
11A	OK-4236-903	Motor 120V Assembly, Analog
11B	OK-4246-903	Motor 230V Assembly, Analog
11C	OK-4286-903	Motor 100V Assembly, Analog
11D	OK-3236-903	Motor 120V Assembly, Digital
11E	OK-3246-903	Motor 230V Assembly, Digital
11F	OK-3286-903	Motor 100V Assembly, Digital
12A	EPP0005	Speed Control, 120V
12B	EB-0246-500	Speed Control, 230V
13A	318-0510-02	120V Line Cord
13B	OK-0246-901	230V Line Cord, without Plug
13C	OK-0256-901	230V line cord, European Plug
13D	OK-0266-901	230V Line cord, British Plug
13E	OK-0276-901	230V Line cord, Swiss Plug
13F	OK-0286-901	100V Line cord
13G	ECP0021	Australian Plug (only)
14	HWP0004	Feet