

OMNI TIP™

HOMOGENIZING KITS

USER MANUAL



OMNI
International

The Homogenizer Company™

WARRANTY INFORMATION

This manual is a guide for the use of the Omni International's Omni Tip™ Homogenizing Kits and accessories.

Data herein has been verified and validated. It is believed adequate for the intended use of the instrument. If the instrument or procedures are used for purposes over and above the capabilities specified herein, confirmation of the validity and suitability should be obtained, otherwise Omni International does not guarantee results and assumes no obligation or liability. This publication is not a license to operate under, or a recommendation to infringe upon, any process patents.

Notes, cautions, and warnings within the text of this manual are used to emphasize important and critical instructions.

This Omni International product is warranted to be free from defects in material and workmanship for a period of ONE YEAR from the date of delivery. Omni International will repair or replace and return free of charge any part which is returned to its factory within said period, transportation prepaid by user, and which is found upon inspection to have been defective in materials or workmanship. For the first 90 days, both parts and service are without charge. For the balance of the period, parts will be provided but service will be charged at established labor rates. This warranty does not include normal wear from use; it does not apply to any instrument or parts which have been altered by anyone other than an employee of Omni International nor to any instrument which has been damaged through accident, negligence, failure to follow operating instructions, the use of electric currents or circuits other than those specified on the plate affixed to the instrument, misuse, or abuse. Omni International reserves the right to change, alter, modify, or improve any of its instruments without any obligation whatever to make corresponding changes to any instrument previously sold or shipped.

THE FORGOING OBLIGATION IS IN LIEU OF ALL OBLIGATIONS AND LIABILITIES INCLUDING NEGLIGENCE AND ALL WARRANTIES OF MERCHANTABILITY OR OTHERWISE, EXPRESSED OR IMPLIED IN FACT OR BY LAW, AND STATE OUR ENTIRE AND EXCLUSIVE LIABILITY AND BUYERS EXCLUSIVE REMEDY FOR ANY CLAIM OF DAMAGES IN CONNECTION WITH THE SALE OR FURNISHING OF GOODS OR PARTS, THEIR DESIGN, SUITABILITY FOR USE, INSTALLATION, OR OPERATION. OMNI INTERNATIONAL WILL IN NO EVENT BE LIABLE FOR ANY SPECIAL OR CONSEQUENTIAL DAMAGES WHATSOEVER, AND THEIR LIABILITY UNDER NO CIRCUMSTANCES WILL EXCEED THE CONTRACT PRICE FOR THE GOODS FOR WHICH LIABILITY IS CLAIMED.

IMPORTANT SAFEGUARDS

-READ ALL INSTRUCTIONS BEFORE USING.

-SAVE THIS OWNER'S MANUAL.

The Omni TH has been engineered for economical functionality as well as safety; however, basic safety precautions and common sense must always be demonstrated when using any electrical product. Do not attempt to modify any part of the Omni TH. If you experience problems with or have questions about your Omni TH, contact your authorized dealer or call Omni International at 1-800-776-4431 or 1-770-421-0058.

DANGER

-DO NOT allow the machine to be submerged in any liquid.

-DO NOT use in any setting other than an indoor laboratory.

-DO NOT plug power cord into an incorrect outlet.

WARNING

To reduce the risk of burns, electrocution, fire, or injury:

-Use this product only for its intended purpose as described in this booklet. DO NOT use attachments not recommended by the manufacturer.

-DO NOT operate the product if it is damaged in any way.

-Keep this product away from heated surfaces.

TABLE OF CONTENTS

Warranty Information	2
Section 1. Omni Tip™ Tissue Homogenizing Kit	
1.1 Omni Tip Kits.....	5
1.2 Optional Accessories.....	6
Section 2. Omni TH, Tissue Homogenizer	
2.1 Specifications.....	7
2.2 Parts and Accessories.....	7
2.3 Stand-Mounting the Omni TH.....	8
Section 3. Omni TH Operation	
3.1 Installing Rotor-Stator Generator Probes.....	8
3.2 Omni Tip™ Plastic Probes.....	9
3.3 Omni TH Operation.....	9
3.4 Theory of Operation.....	10
Section 4. Operational Guidelines	11
Section 5. Omni Tip™ Plastic Probes	
5.1 Specifications.....	13
5.2 Installing Omni Tips™.....	14
5.3 Chemical Resistance.....	15
5.4 Autoclaving Omni Tips.....	15
5.5 Cleaning the Omni Tip™ Adapter.....	15
Section 6. Motor Maintenance	
6.1 Motor Drive Unit.....	16
6.2 Brush Maintenance.....	16
6.3 Motor Bearings.....	16
6.4 Storage.....	16
6.5 Wiring Diagram.....	17
6.6 Replacement Parts.....	18
Section 7. Service	
7.1 Assistance.....	19
7.2 Decontamination.....	19
Section 8. Troubleshooting	19

SECTION I. OMNI TIP™ TISSUE HOMOGENIZING KITS

I.1 OMNI TIP™ KITS

Omni's convenient Tissue Homogenizing Kits come with everything needed to homogenize tissue samples quickly and efficiently for successful RNA extraction. Each kit includes an Omni TH Homogenizer with an adapter for mounting Omni Tips™ generator probes (see Section 5 for more information). A choice of stainless steel rotor-stator generator probes is also available (see Section 6 for more information). Omni's Tissue Homogenizing Kits are designed for situations where molecular contamination between samples cannot be tolerated. Stainless steel generator probes are available for efficient processing of frozen and/or fibrous tissues. Omni Tips™ are ideal when molecular contamination is of the utmost concern and are most beneficial when working with soft, unfrozen tissues. It is important that the diameter and length of the selected generator probe will fit securely within the vessel being used and the generator probe (plastic or stainless steel) is appropriate for the application.



Omni Tip Kit with 7mm Stainless Steel Generator Probe

**Our Applications database can help you
find the best solution - quickly.**

Our constantly expanding database consists of carefully reviewed customer published applications, sorted into useful categories, complete with product recommendations to help you find the right laboratory homogenizer for any sample type.

If you can't find an answer in the database, call us and we'll help!

www.omni-inc.com/applications

SECTION I. OMNI TIP™ TISSUE HOMOGENIZING KITS

I.2 OPTIONAL ACCESSORIES

Omni Tip™ Homogenizing Kits are supplied with a handheld Omni TH Homogenizer. For applications where hands-free operation is desired, an optional stand assembly is available. A post clamp assembly is included with the Omni TH for post-mounting the unit to any comparable size ring stand.

<u>Part Number</u>	<u>Description</u>
SI000	Stand Assembly Kit:

Additional Omni Tip™ generator probes are available in boxes of 25, 50, 100, or 500. Omni Tips™ are 110mm long and 7mm in diameter. The adapter included in Omni's Tissue Homogenizing Kits is required for mounting Omni Tips™ to the Omni TH Homogenizer, and is not disposable. See Section 5 for more information about Omni Tips™.

<u>Part Number</u>	<u>Description</u>
A1000SB	Omni Tip Adapter
30750	25 Omni Tips™
30750H	25 Hard Tissue Omni Tips™
32750	50 Omni Tips™
32750H	50 Hard Tissue Omni Tips™
34750	100 Omni Tips™
34750H	100 Hard Tissue Omni Tips™
35750	500 Omni Tips™
35750H	500 Hard Tissue Omni Tips™
3M750	1000 Omni Tips™
3M750H	1000 Hard Tissue Omni Tips™



Omni Tip™ Plastic Probes

SECTION 2. OMNI TH, TISSUE HOMOGENIZER

The Omni TH, Tissue Homogenizer is a variable speed, handheld or post-mounted homogenizer. It combines a high-speed, high-torque motor with a choice of autoclavable rotor-stator generator probes of various Diameters or Omni Tip™ Plastic Probes.

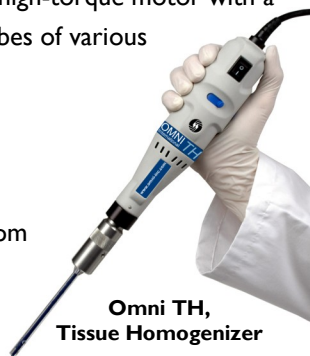

2.1 SPECIFICATIONS

Motor Speed:	5,000-35,000rpm
Capacity:	0.03-100ml
Height (motor only):	22.9cm (9 in)
Weight (motor only):	466g (16.4oz)
Electrical Requirements:	115V, 60Hz or 220V, 50Hz
Standards Approval/Compliance:	220V: CE Certified

2.2 PARTS AND ACCESSORIES

Prior to operation, please remove all parts from the shipping container and inspect for damaged or missing parts. If any parts are found to be damaged or missing, please contact Omni International at 1-800-776-4431.

The Omni TH, Tissue Homogenizer consists of the following:

<u>Description</u>	<u>Part Number</u>	<u>Quantity</u>
Motor Drive Unit		1
(115V)	TH-01	
(220V)	TH-02	
Post Clamp Assembly	I2-118	1
Tool Kit	T1001	1
Instruction Manual	H258-TH	1

A stand assembly (base plate, 24" post, cross rod, and post clamp), PN S1000, is available for use with the Omni TH, Tissue Homogenizer, but is not supplied with the instrument.

SECTION 2. OMNI TH, TISSUE HOMOGENIZER (cont.)

2.3 STAND-MOUNTING THE OMNI TH (Optional)

To mount the Omni TH, Tissue Homogenizer to a stand assembly, refer to the figure and follow these steps:

- 1) Secure the 24" post by twisting it into the base plate until securely tightened.
- 2) Loosen the locking knob and slide the included post clamp assembly down over the end of the post until the clamp is at the desired height and lock in place.
- 3) Slide the TH motor into the opening on the end of the post clamp assembly and push it down firmly. The unit will lock in place.
- 4) To remove the TH, press the black button on the back of the opening of the post clamp assembly and lift the motor from the cradle.

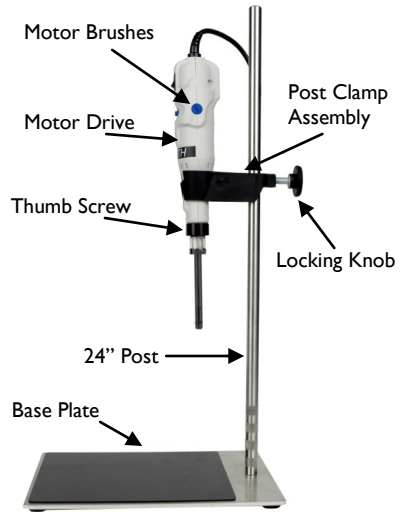

2.1 INSTALLING ROTOR-STATOR GENERATOR PROBES

Stainless steel rotor-stator generator probes are easily installed to the Omni TH motor by means of a quarter-turn bayonet mount. Simply push the generator probe into the motor housing as far as possible, turn clockwise, and release. Turn the thumb screw clockwise to tighten. Remove the blue protective cap from the tip of the generator probe and the Omni TH is ready to operate.

WARNING: The tip of the saw tooth generator probe is sharp.

CAUTION: When using glass-filled Teflon lower bearings, do not operate the unit for extended periods of time without immersing the bottom of the generator probe in liquid or the sample being processed in order to avoid premature failure of the lower bearing.

SECTION 3. OMNI TH OPERATION

3.2 OMNI TIP™ PLASTIC PROBES

An Omni Tip™ Adapter (A1000SB) is required to use Omni Tip™ Plastic Probes with the Omni TH Homogenizer. First, insert the smaller end of the Omni Tip Adapter into the Omni TH as far as possible, turn clockwise, and release. Next, insert an Omni Tip™ Plastic Probe into the Omni Tip™ Adapter as far as possible, turn clockwise, and release. The TH is now ready to operate. Omni Tips™ can be disposed of after use.

3.3 OMNI TH OPERATION

Connect the Omni TH to an appropriate power outlet. Speed of the Omni TH varies between 5,000 and 35,000 rpm and is set by means of the blue slider switch. The power switch located above the blue slider switch turns the motor on and off.

WARNING: Reduce the risk of unintentional starting; make sure that the power switch is in the OFF position prior to plugging in the unit.

Insert the generator probe into the Omni TH motor (see above). The depth of the generator probe in the sample vessel can significantly affect flow patterns within the vessel. This also affects processing efficiency. As a rule of thumb, the generator probe usually operates most efficiently at a depth of 1/3 (to 1/2) of the liquid height. Heavy sediments may require deeper immersion, and this processing depth can be optimized by observing flow patterns and related processing results. While processing, liquid can circulate through the two holes at the bottom of the generator probe. When using a stainless steel probe, the top hole should not be immersed in the sample. Blocking the upper hole could result in liquid being drawn into the lower motor bearing.

Operating at the top speed of 35,000rpm enhances the processing efficiency of the rotor-stator generator probe. For most samples, three to four short bursts at top speed should be sufficient for complete homogenization of the sample.

WARNING: The Omni TH, Tissue Homogenizer has an internal speed control. An external speed control should never be used with this instrument.

SECTION 3. OMNI TH OPERATION

NOTE: For optimal sample recovery during processing, reduce the motor speed and completely remove the generator probe from the sample. Then turn off the motor drive unit.

WARNING: DO NOT process pathogenic material in an open container, since aerosols created during normal processing could be inhaled by the operator. Please call for assistance in processing pathogens or other material which require sealed enclosures.

3.4 THEORY OF OPERATION

The rotor shaft is coupled directly to the drive motor, via the drive pin. When attached to the homogenizer motor, the rotor shaft can spin up to 35,000rpm. This assembly makes up the rotor portion of the rotor-stator generator probe. The tube/collar assembly is attached to the motor housing, but does not spin. This is the stator portion of the rotor-stator generator probe. As the rotor knife spins within the tube and collar assembly, it creates a pumping action, pulling the sample into the open end of the generator probe and forcing the sample out through the windows in the tube. The interaction of the rotor knife with these windows sets up a shearing action, reducing the particle size of the sample. The speed differential between the rapidly moving portion and the relatively stationary portion of the sample sets up a second force called cavitation which pulls the sample apart, further reducing the particle size.

The processing efficiency can be affected by:

- Amount of material processed vs. size and speed of the generator probe.
- Container geometry and size (round vessels encourage swirling, while fluted or cornered vessels disrupt flow patters for more effective mixing/ processing).
- Processing speed vs. optimal speed.
- Size and type of material and flow characteristics (material particles must be small enough to be carried into the generator head for optimal processing).

SECTION 4. OPERATIONAL GUIDELINES

4.1 OPERATIONAL GUIDELINES

Rotor-stator homogenization provides highly efficient cellular lysis and membrane disruption while reducing the high-molecular weight of cellular components. Omni Tip Tissue Homogenizing Kits allow rapid and complete disruption of cell lysates to expose intracellular contents and ensure increased yields. A choice of rotor-stator generator probes, in plastic or stainless steel, process a wide range of sample preparation applications.

Non-sterile, plastic Omni Tips™ generator probes are ideal for situations where molecular contamination between samples cannot be tolerated. Omni Tips™ were designed to be disposed of after each use, eliminating cross contamination risks along with the time and effort normally required for cleaning. While Omni Tips™ can be autoclaved up to seven times for repeated use, they are not recommended for extended use with phenol or guanidine-based reagents (see Section 5.3 for chemical resistance compatibility). Disposal may be required when used in conjunction with these reagents.

Stainless steel generator probes are best for difficult-to-process tissues and for situations where sample-to-sample contamination is not a concern. Stainless steel generator probes are equipped with a Teflon bearing. Omni's stainless steel generator probes can be quickly disassembled for thorough cleaning and bearing maintenance.

Omni's stainless steel generator probes are available in many configurations tailored for specific sample types. Flat bottom generator probes are recommended for liquid or soft tissues, while saw tooth and extended blades are best for processing fibrous tissues. For situations where preprocessing or cutting the tissue prior to homogenization is inconvenient, wide windows allow larger pieces of sample to effectively pass through the processing head where shearing occurs.

SECTION 4. OPERATIONAL GUIDELINES

Regardless of which type of generator probe is being used, the following factors can affect processing efficiency:

- **Size and Type of Material Being Processed:**
Solid particles, in any dimension, should be no more than half the diameter of the rotor-stator generator probe for optimal processing. This is extremely important when using the Omni Tip™ disposable generator probes. Stainless steel generator probes with extended blades and/or wide windows are available for processing large, solid samples.
- **Processing Speed:**
Omni Tip Homogenizing Kits include a handheld Omni TH Homogenizer with motor speeds up to 35,000rpm. Operating at the top speed enhances processing efficiency of the generator probes (both plastic and stainless steel) supplied with the Omni Tip™ Kits.
- **Container Geometry and Size:**
Round vessels encourage swirling. Fluted or cornered vessels disrupt flow patterns, allowing for more effective mixing/processing.

Should further information or assistance be required for using Omni Tip™ Homogenizing Kits, please contact Omni International, Inc.

Toll free: 1-800-776-4431
Outside the US: 1-770-421-0058
Fax: 1-770-421-0206
E-mail: omni@omni-inc.com



5mm



7mm



10mm

Stainless Steel Rotor-Stator Generator Probes

SECTION 5. OMNI TIP™ PLASTIC PROBES

5.1 SPECIFICATIONS

7mm Diameter Disposable Plastic Generator Probe

Minimum Vessel Inside Diameter: 8mm

Applications:

Soft Tissue Omni Tips: liquid/liquid or soft tissue processing

Hard Tissue Omni Tips: frozen or fibrous tissue processing

Processing Range: 0.25–30ml

Length: 110mm

The Omni Tips™ are disposable rotor-stator generator probes constructed of durable plastic. Although Omni Tips™ are designed specifically to be disposed of after each use to eliminate sample cross-contamination, for many applications, the probe can be cleaned, sterilized, or disinfected and reused by the procedures described below.

Soft Tissue Omni Tip™



Hard Tissue Omni Tip™

NOTE: Omni Tip™ plastic probes are not factory presterilized or disinfected. If this is a requirement, please use one of the recommended methods described below.

	<u>Recommended</u>	<u>Not Recommended</u>
<u>Sterilization</u>		
<u>Techniques:</u>	<ul style="list-style-type: none"> * Autoclave up to 250°F * Ethylene Oxide * Formaldehyde * Gluteralhyde (2%) * Gamma irradiation up to 5 MRAD 	<ul style="list-style-type: none"> *UV Irradiation
<u>Biological</u>		
<u>Disinfection:</u>	<ul style="list-style-type: none"> * Alcohol (70%) * Hypochlorite (5%) [chlorine bleach] * Formaldehyde (40%) 	<ul style="list-style-type: none"> *Phenolic Derivatives *Extended Exposure to Guanidine *Dichloromethane
<u>Radioactive</u>		
<u>Decontamination:</u>	<ul style="list-style-type: none"> * Radiacwash * Count-off * Water/ Ethanol/ SDS 	

SECTION 5. OMNI TIP™ PLASTIC PROBES

WARNING: Safety glasses are recommended when using Omni Tip™ plastic probes. It is possible for plastics to shatter or break after exposure to certain chemicals, or after repeated autoclaving.

CAUTION: Large, solid particles, such as frozen tissue, may cause damage to the standard Omni Tip™ generator probes. Use the Hard Tissue Omni Tips™ for those applications.

5.2 INSTALLING OMNI TIPS™

See Section 2.2

CAUTION: Omni Tip plastic probes should not be immersed above the cone leading to the adapter during processing, since liquid may be drawn up the shaft and contaminate the coupling.

5.3 CHEMICAL RESISTANCE

Omni Tips™ generator probes are made of polycarbonate and an amorphous thermoplastic polythermide. The plastics used in Omni Tips™ have good chemical resistance to weak acids, chlorides, hypochlorides, and many other chemicals, allowing for reuse. However, phenol or guanidine-based reagents, commonly used in PCR studies, are not recommended for extended use with Omni Tips™. Exposure to these chemicals shortens the life of Omni Tips™ and usually results in disposal after each use. Therefore, reuse is not guaranteed in such circumstances. If any cracking or brittleness is detected in an Omni Tips™ generator probe, it is recommended that it be discarded. Due to the many different chemicals and environments in which processing takes place, it is the responsibility of the user to set sterilization guidelines and protocols to optimize the life and performance of their Omni Tips™ generator probes.

SECTION 5. OMNI TIP™ PLASTIC PROBES

5.4 AUTOCLAVING OMNI TIPS™

Omni Tips™ generator probes can be autoclaved up to seven times and retain their mechanical properties. Due to different combinations of chemicals and environments, it is suggested that the autoclaving recommendations be followed as a guideline only, and the user should decide how to best alter the procedure for their specific application.

The tube and shaft of Omni Tips™ can be autoclaved at up to a maximum of 250°F for 45 minutes. This includes a 15-minute ramp up, 15-minute hold, and a 15-minute ramp down of the temperature cycle. If the tube or shaft begins to warp as a result of autoclaving, discard and lower the cycle time or temperature level accordingly for future runs.

5.5 CLEANING THE OMNI TIP™ ADAPTER

The Omni Tip™ adapter is constructed of stainless steel with steel and Aluminum rotating components. For general cleaning, it is recommended that the adapter be wiped down with a lint free cloth and an alcohol solution. Adequate molecular contamination cleaning can also be accomplished by scrubbing with soap and hot water, followed by brief rinsing with 1% SDS, and then by distilled water which has been treated with diethylpyrocarbonate (DEPC). **Autoclaving, baking, or submersion in cleaning agents is not recommended;** this will shorten the life of the adapter housing and bearings.



Omni Tip™ Adapter

SECTION 6. MOTOR MAINTENANCE

6.1 MOTOR DRIVE UNIT

The Motor drive housing should be wiped off after use, especially when concentrated and potentially damaging liquids are used during processing. Never use solvents to clean unit or accessories.

6.2 BRUSH MAINTENANCE

If the performance of your Omni TH, Tissue Homogenizer begins to deteriorate in any of the following ways:

- The operations speed begins to decline
- The unit stalls intermittently
- The unit stops working all together

It probably requires a new set of brushes. The average brush life for the Omni TH, Tissue Homogenizer is 80-100 hours. For service, or brush replacement, please contact Omni International at 1-800-776-4431.

6.3 MOTOR BEARINGS

The Omni TH, Tissue Homogenizer motor is equipped with sealed ball bearings. Under normal use they require no additional lubrication.

6.4 STORAGE

The unique design of the Omni TH, Tissue Homogenizer allows the handheld unit to stand vertically on a bench-top or shelf so that it can be stored in less than six square inches of space.

WARNING: Keep all housings in place and in working order.

WARNING: Remove all tools from the generator probe before turning the motor on.

WARNING: DO NOT use the motor in a dangerous environment.

WARNING: Disconnect the motor before servicing, and when changing the generator probe.

SECTION 6. MOTOR MAINTENANCE

WARNING: DO NOT modify the plug or cord that is provided. If the plug will not fit the outlet, have the proper outlet installed by a qualified electrician.

WARNING: Reduce the risk of unintentional starting; make sure the power switch is in the OFF position before plugging in the motor.

WARNING: Damaged or worn power cords should be repaired or replaced immediately by a qualified electrician.

WARNING: Improper connection of the equipment can result in a risk of electric shock.

6.5 WIRING DIAGRAM

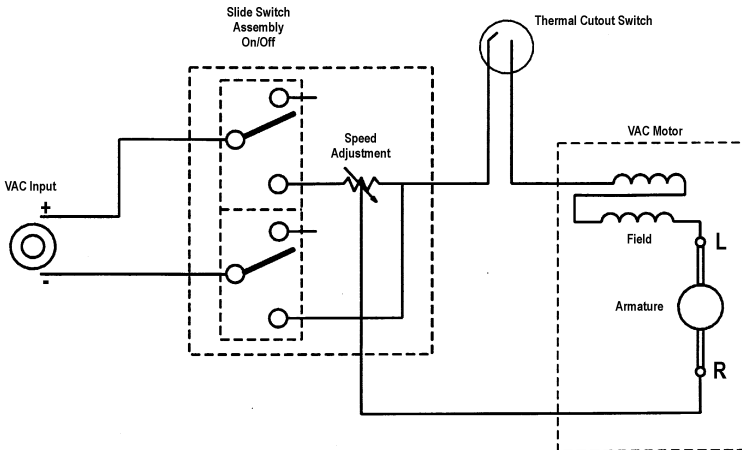

SECTION 6. MOTOR MAINTENANCE

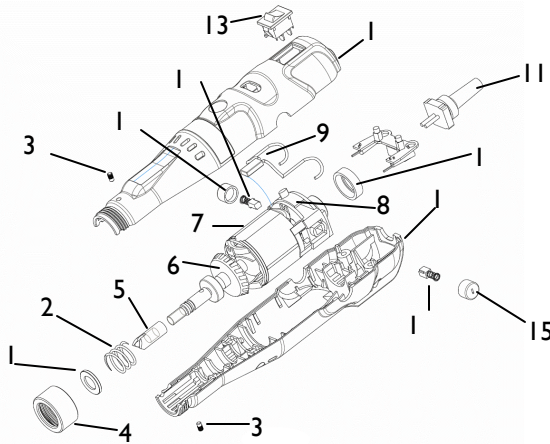

6.6 REPLACEMENT PARTS

Table of Replacement Parts for the Omni TH, Tissue Homogenizer

#	Description	115V	220V
1	Aluminum Washer	12-113	12-113
2	Wave Spring	00-544	00-544
3	Set Screws	00-695	00-695
4	Coupling	12-112	12-112
5	Bearing Insulator	12-114	12-114
6	Armature Assembly	TH1152_B	TH2252
7	Field Assembly	20052_B	20252
8	Speed Switch Assembly	20010_B	22010
9	Thermal Sensor	00-122	00-122
10	TH Bearing Support	TH1157_B	TH1157_B
11	Power Cord	TH1151_B	TH2251_B
12	Housing Assembly	TH1151_B	TH1151_B
13	On/Off Switch	00-115	00-115
14	Armature Brush (pack of 2)	62810	62810
15	Brush Caps (pack of 2)	20811	20811

SECTION 7. SERVICE

7.1 ASSISTANCE

Should this product ever require service, please contact Omni International at 1-800-776-4431.

7.2 DECONTAMINATION

Should an instrument or component that has been used with radioactive or pathogenic material require factory or field service, comply with the following procedure to ensure the safety of service personnel:

- Clean the parts to be serviced of all encrusted material and decontaminate them. There must be no radioactivity detectable by survey equipment.
- Obtain a Decontamination Certificate from Omni International. Complete the certificate and attach to the instrument or parts being returned.

If no Decontamination Certificate is attached, and a potential radioactive or biological hazard is detected or suspected by Omni International, the equipment will not be serviced until proper decontamination and certification is complete. The sender will be contacted for instructions as to the disposition of the equipment. Disposition costs will be borne by the sender.

WARNING: It is a violation of federal law to transport biologically hazardous or radioactive materials without proper packaging, labeling, and appropriate warnings.

SECTION 8. TROUBLESHOOTING

Do not attempt to service the Omni TH in a manner other than those discussed in this manual. For any issue that is unsuccessfully corrected using this guide, please contact your authorized dealer or call Omni International technical assistance at 1-800-776-4431 or 1-770-421-0058.

PROBLEM	CORRECTIVE ACTION
The Omni TH is plugged in and turned on but is not functioning.	-Check power cord connectors -Check wall socket for power to the outlet
Motor is turned ON and makes a makes a “buzzing” sound, but is not working.	-Check that the brushes are not worn and are correctly installed. Replace if necessary. (see Section 3.2)
Motor unit operating speed declines, stalls intermittently, or stops completely	-Check that the brushes are not worn and are correctly installed. Replace if necessary. (see Section 3.2)
Teflon bearing wears quickly	-Fluid level may be too low in the tube. -Immerse the probe deeper into the fluid.
Excessive splashing in sample tube	-Fluid level too low for tube size



935-C Cobb Place Blvd.
Kennesaw, GA 30144
Email: omni@omni-inc.com

Toll Free: 1-800-776-4431
Phone: 770-421-0058
FAX: 770-421-0206

Patents Pending

Rev. 01/25/11 rb

P/N: PCR-258

www.omni-inc.com