

Sealer

Model 305-C Cod. 5800042

INSTRUCTIONS MANUAL

1 PARTS IDENTIFICATION

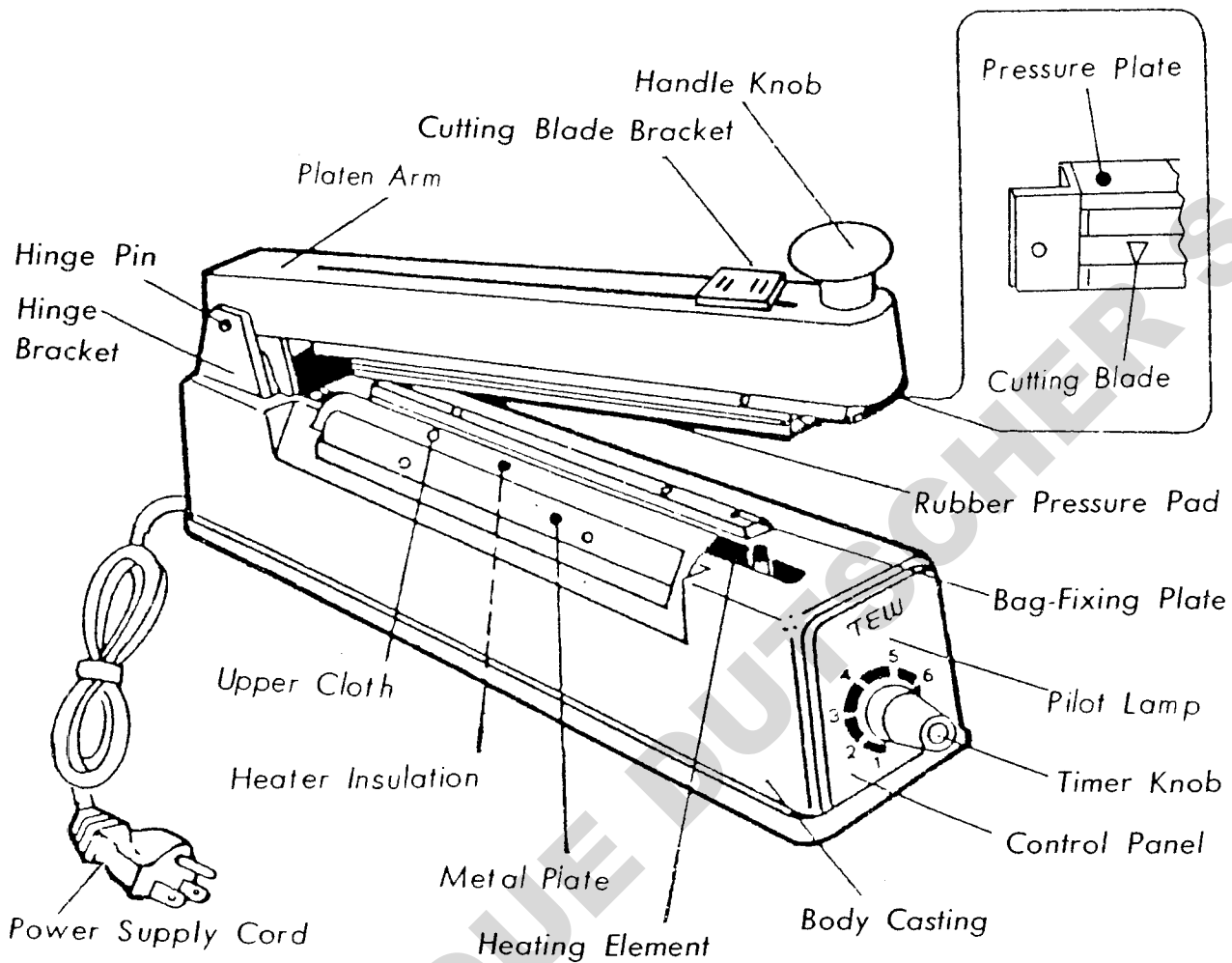

FIG. 1 (ONLY USE FOR TISH-200C, 300C)

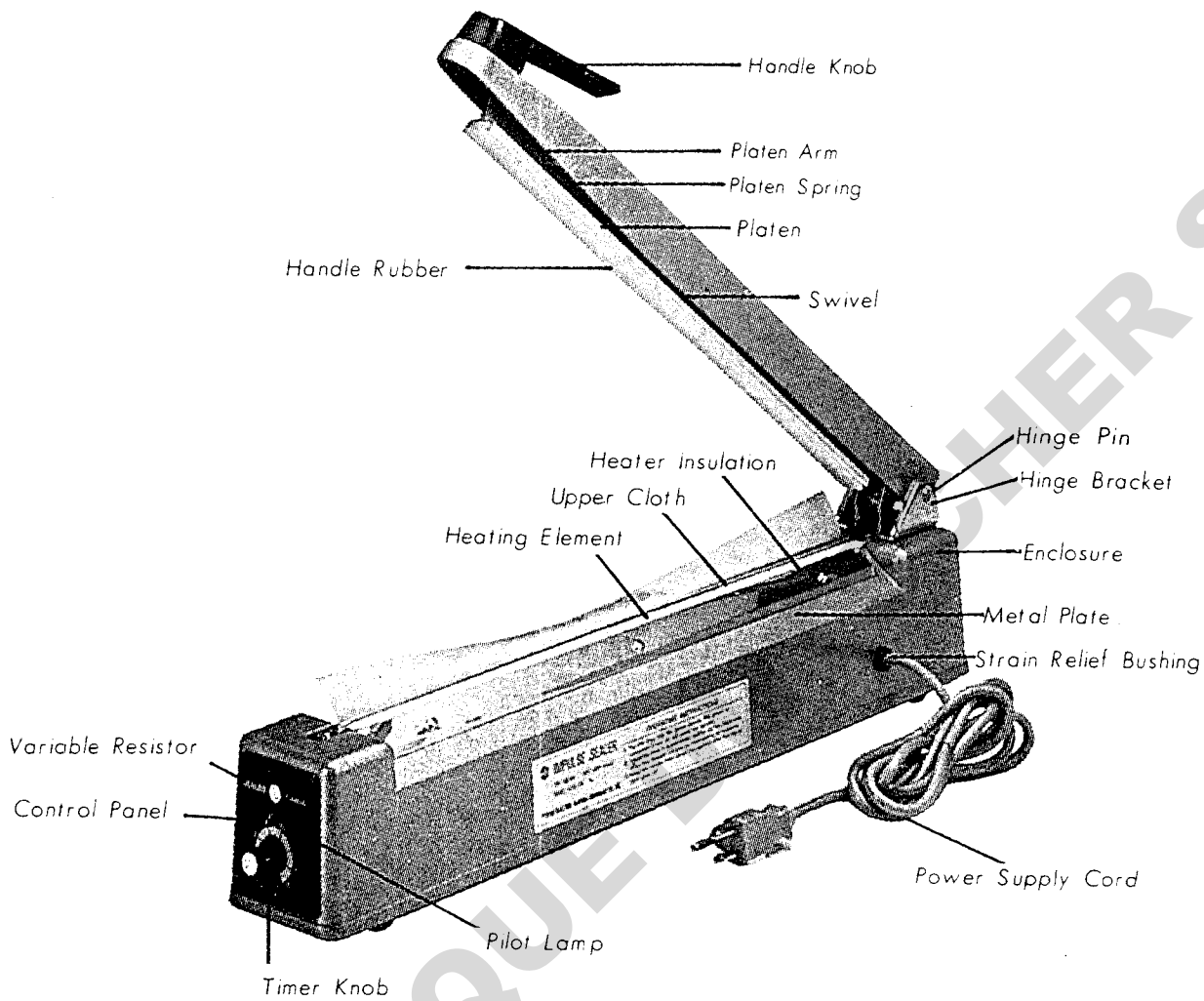

FIG. 2 (ONLY USE FOR TISH-100, 200, 300, 400)

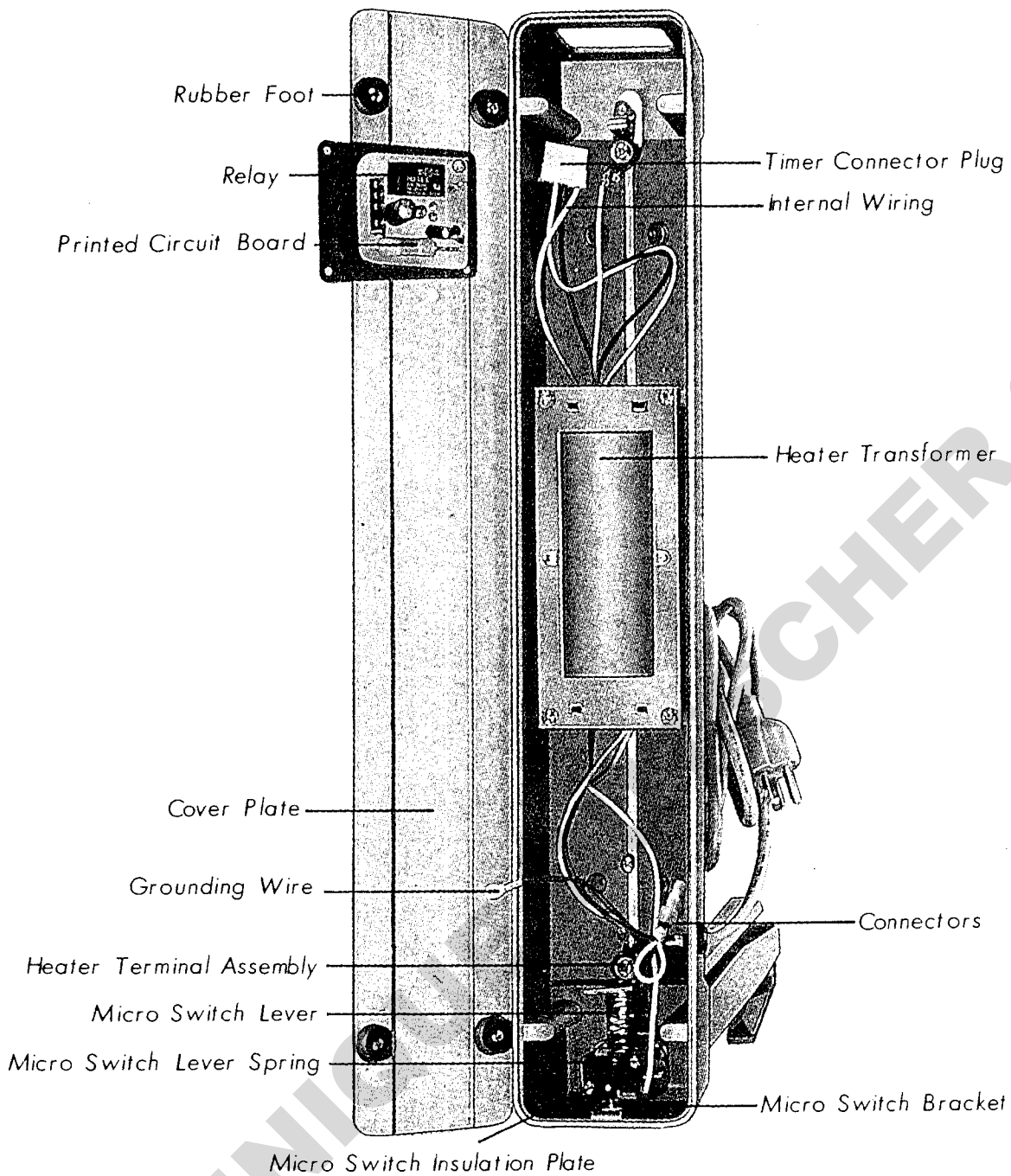
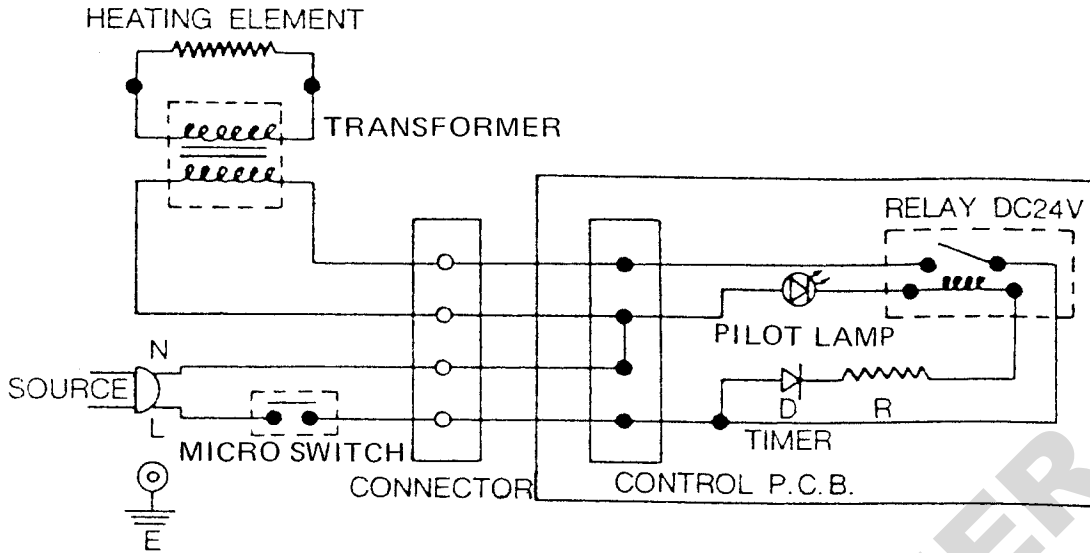

FIG. 3 (USE FOR TISH 100, 200, 300, 400, 200C, 300C)

2 CONNECTION DIAGRAM



3 PURPOSE

These Impulse Sealers **TISH-100** **TISH-200C**
-200 **300C**
-300
-400

are the perfect sealers for PE and PP bags to package various kinds of candy, foodstuff, general merchandise, stationery, drugs, etc.

4 CHARACTERISTICS

- CONVENIENT AND COMPACT IN SIZE
- USES ENERGY ONLY WHEN SEALING
- PRECISION ELECTRONIC CONTROL CIRCUIT
- DESIGNED TO BE EASY TO USE.

5 OPERATION

- This machine does not use a power switch. Plug the AC cord into the power source, Set the timer knob according to the thickness of the materials to be sealed. The higher the number on the dial, the longer the heat sealing time. Put one plastic bag on the sealing platform, and then push down the handle. The electronic circuit controls the heat time automatically, the light turns off (to cut off the power automatically). After 1–2 seconds, release the handle. The perfect seal is complete.
- In case of a break or if damage appears on the seal, it is because of too long a heating time. Adjust the timer knob toward the direction of a lower number for a shorter heating time.
- A non-tight seal is caused by too short a heating time. Adjust the timer knob toward the direction of a higher number for a longer heating time.
- Should the plastic bag stick to the handle rubber, or if it is pulled, it means the cooling time should be longer, Keep the handle down for a short time after the light turns off.
- Slide the knife to cut off the rest of the bag.
(only use for Tish-200C, 300C)

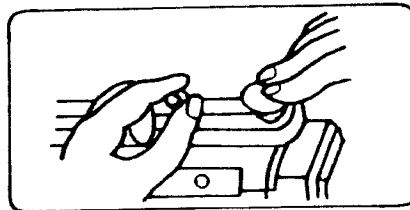

- After the timer knob has been set, the heat time duration will remain the same for each usage. It is unnecessary to make any adjustments for continuous sealing.
- It is okay to leave the AC Cord plugged into the power source. No power is used unless the handle is pressed down.

6 HEATING TIME ADJUST

MODEL \ SCALE RANGE	1-2	3-4	5-6	7-8
TISH-100 200 200C	0.05mm	0.1mm	0.2mm	0.3mm
TISH-300 300C 400	0.08mm	0.15mm	0.3mm	0.4mm

(SETTING FOR PE BAGS)

7 NOTES

- Always keep the sealing platform clean. Avoid the oxidation of the residual on the platform which will reduce the life of the heating element and of the heat-resisting teflon.
- Do not use water to clean the sealing platform.
- Should the bottom teflon cloth wear out, it will cause a short circuit and damage the heating element. Each time you replace the heating element or the top teflon, check the bottom teflon. Replace it with a new bottom teflon if the old one is worn.
- Only use original equipment replacement wires and other parts.
- A worn silicon handle rubber will influence the sealing effect. After a long period of usage, it should be checked.

8 SPARE PARTS

MODEL	TISH-100•200•300•400	TISH-200C•300C
HEATING ELEMENT	2 PCS	2 PCS
UPPER CLOTH	2 PCS	2 PCS
CUTTING BLADE	—	1 PCS