

pipetman

NEO®

User's Guide

EN



NOTICE

Do not lubricate this pipette.
The use of lubricant cancels
the warranty of this pipette.

TABLE OF CONTENTS

INTRODUCTION | 3

Parts Checklist | 3

GLP Features | 3

Description | 4

Specifications | 6

SETTING THE VOLUME | 8

PIPETTING | 9

Fit the tips | 9

Pre-rinse the tips | 11

Aspirate | 11

Dispense | 12

Guidelines for Good Pipetting | 12

ACCESSORIES | 14

TROUBLESHOOTING | 15

Troubleshooting Table | 15

Leak Test | 16

MAINTENANCE | 17

Single channel models | 18

Multichannel models | 21

CLEANING AND DECONTAMINATION | 21

SPARE PARTS | 26

WARRANTY | 30

Chapter 1

INTRODUCTION

PIPETMAN Neo® is a fully adjustable air displacement pipette and is used with disposable tips.

PIPETMAN Neo is an evolution of the Pipetman Classic to address the growing susceptibility of pipette users to repetitive strain injuries. The implementation of new features to improve pipetting comfort has no impact on the legendary robustness, accuracy and precision of PIPETMAN.

- Six single channel models cover a volume range from 0.2 µL to 1000 µL.
- Two 8 and two 12 multichannel models cover a volume range from 2 µL to 200 µL.

Parts Checklist

After unpacking the pipette, verify that the following items were included and are undamaged:

- PIPETMAN Neo
- *PIPETMAN Neo User's Guide*
- Safety Bag
- Certificate of Conformity (including barcode sticker)

GLP Features

The **serial number** is engraved on the body of the pipette. It provides unique identification of your pipette and the date of manufacture; Ex: AA 10369

The **barcode** on the box and the certificate of conformity provide traceability of your pipette.



Figure 1
Serial Number Location

Description

Please refer to the following chapters for a full description of the different parts and functions of the pipette.

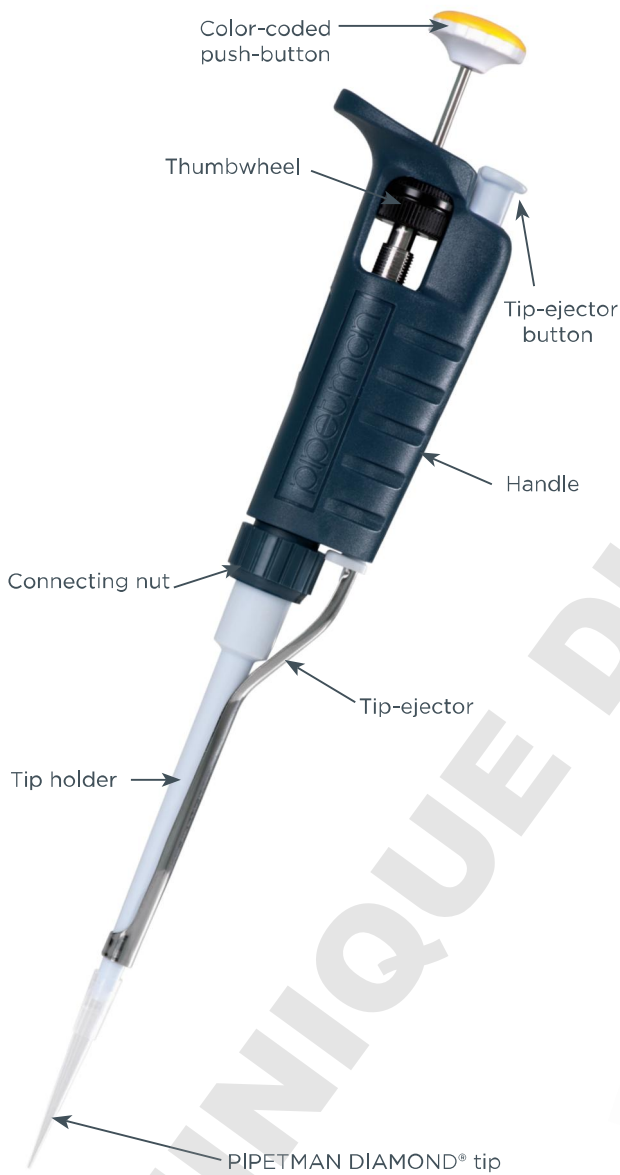

Figure 2
PIPETMAN Neo® single channel



Figure 3
PIPETMAN Neo® multichannel



Maximum Permissible Errors

The data provided in the following table conform to the ISO 8655-2 Standard. With a precise pipetting technique (refer to [Guidelines for Good Pipetting](#) on page 12) the P2N model may be used to aspirate volumes as low as 0.1 µL and the P10N model as low as 0.5 µL.

PIPETMAN Neo is a high quality pipette that offers excellent accuracy and precision. The figures given in the “Gilson Maximum Permissible Errors” table (page 7) were obtained using PIPETMAN DIAMOND Tips. These figures are guaranteed only when genuine PIPETMAN DIAMOND Tips are used.

Each pipette is inspected and validated by qualified technicians in accordance with the Gilson Quality System.

Gilson declares that its manufactured pipettes comply with the requirements of the ISO 8655 standard, by type testing.

The adjustment is carried out under strictly defined and monitored conditions (ISO 8655-6).

VOLUME*	GILSON		ISO 8655	
	SYSTEMATIC ERROR	RANDOM ERROR	SYSTEMATIC ERROR	RANDOM ERROR
P2N WITH D10 OR DL10 TIPS (P/N F144561)				
Min	0.2	±0.024	≤0.012	±0.08
	0.5	±0.025	≤0.012	±0.08
Max	2	±0.030	≤0.014	±0.08
P10N WITH D10 OR DL10 TIPS (P/N F144562)				
Min	1	±0.025	≤0.012	±0.12
	5	±0.075	≤0.030	±0.12
Max	10	±0.100	≤0.040	±0.12
P20N WITH D200 TIPS (P/N F144563)				
Min	2	±0.10	≤0.03	±0.20
	10	±0.10	≤0.05	±0.20
Max	20	±0.20	≤0.08	±0.20
P100N WITH D200 TIPS (P/N F144564)				
Min	10	±0.35	≤0.10	±0.80
	50	±0.40	≤0.12	±0.80
Max	100	±0.80	≤0.15	±0.80
P200N WITH D200 OR D300 TIPS (P/N F144565)				
Min	20	±0.50	≤0.20	±1.60
	100	±0.80	≤0.25	±1.60
Max	200	±1.60	≤0.30	±1.60
P1000N WITH D1000 OR D1200 TIPS (P/N F144566)				
Min	100	±3	≤0.6	±8
	500	±4	≤1.0	±8
Max	1000	±8	≤1.5	±8
P8X20 (P/N F14401) AND P12X20 (P/N F14402)				
Min	2	±0.10	≤0.08	±0.40
	10	±0.20	≤0.10	±0.40
Max	20	±0.40	≤0.20	±0.40
P8X200 (P/N F14403) AND P12X200 (P/N F14404)				
Min	20	±0.50	≤0.25	±3.2
	100	±1.0	≤0.40	±3.2
Max	200	±2.00	≤0.60	±3.2

*All Values in Microliters



Chapter 2

SETTING THE VOLUME

The volume of liquid to be aspirated is set using the volumeter. The dials are colored either black or red to indicate the position of the decimal point, depending on the model (see examples).

The volume is set by turning the thumbwheel or the push button. The push button makes it easier and quicker to set volumes, especially when wearing gloves. The thumbwheel may be turned using only one hand to slowly reach the required setting.

To obtain maximum accuracy when setting the volume:

- When **decreasing** the volume setting, slowly reach the required setting, making sure not to pass the setting.
- When **increasing** the volume setting, pass the required value by 1/3 of a turn and then slowly decrease to reach the volume, making sure not to pass the setting.



Figure 5
Dial Colors by Model



Figure 4
Location of Push Button and Thumbwheel

MODEL	COLOR OF VOLUMETER NUMBERS		
	BLACK	RED	INCREMENT
P2N	μL	0.01 μL	0.002 μL
P10N to P20N	μL	0.1 μL	0.02 μL
P100N-P200N	μL	—	0.2 μL
P1000N	0.01 mL	mL	0.002 mL

Chapter 3

PIPETTING

It is recommended to use PIPETMAN® DIAMOND Tips with the PIPETMAN Neo for optimum performance. These tips are made from pure polypropylene. Plastic tips are for a single application—they must not be cleaned for reuse.

Fit the Tips

Single channel models

To fit a new PIPETMAN DIAMOND tip, push the tip holder into the tip using a slight twisting motion to ensure a firm and airtight seal.

NOTE

For the P2N and P10N models, a dual-position adapter (plastic) is required to fit DL10 tips (long tips) or D10 tips (short tips). The metallic rod of the tip-ejector is shaped so that the adapter may be clipped to it in either of two positions.

P2N and P10N models are delivered with the adapter in place, positioned in the longer slot, and ready to use DL10 tips. When D10 tips (which are shorter) are used, the adapter must be repositioned in the shorter slot as follows:

1. Pull the adapter down from the metallic rod.
2. Turn the adapter 180°.
3. Refit the adapter so that the end of the metallic rod engages the shorter slot of the adapter.



Figure 6
Dual-Position Adapter for P2 and P10

Multichannel models

PIPETMAN DIAMOND Tip:

Tipack™ and Towerpack™ – Rocky Rack™

PIPETMAN DIAMOND Tips are best fitted from the patented Rocky Rack available only in our Tipacks and Tower packs.



Rocky Rack is the dome-shaped part of the pack that contains the tips. Rocky Rack makes it easy to securely fit the tips to a multichannel pipette, ensuring an airtight seal on all channels without the need to use undue pressure or to touch the tips.

NOTE

The patented **ROCKY RACK** system available on **TOWERPACK** and **TIPACK** makes it extremely easy to fit tips on a multichannel pipette. Tips will not fall off nor will they have to be manually positioned.

PIPETMAN DIAMOND TIP COMPATIBILITY

8x20 12x20	DL10, DFL10, DF30, D200
---------------	----------------------------

8x200 12x200	D200, D300, DF100, DF200, DF300
-----------------	------------------------------------



Figure 8
PIPETMAN Neo
multichannel ejector
spacer

**Figure 7**

Tip fitting on a multichannel pipette with the ROCKY RACK system

Pre-Rinse the Tips

Some liquids (e.g., protein-containing solutions and organic solvents) can leave a film of liquid on the inside wall of the tip; pre-rinse the tip to minimize any errors that may be related to this phenomenon.

Pre-rinsing consists of aspirating the first volume of liquid and then dispensing it back to the same vessel or to waste. Subsequent volumes that you pipette will have levels of accuracy and precision within specifications.

Aspirate

1. Press the push button to the **first stop** (this corresponds to the set volume of liquid).
2. Hold the pipette vertically and immerse the tip in the liquid (for the immersion depth, refer to [Guidelines for Good Pipetting](#) on page 12). Release the push button slowly and smoothly (to top position) to aspirate the set volume of liquid. Wait one second, the time depends on the model (refer to the table), then withdraw the pipette tip from the liquid. You may wipe any droplets away from the outside of the tip using a medical wipe; however, if you do so, take care to avoid touching the tip's orifice.

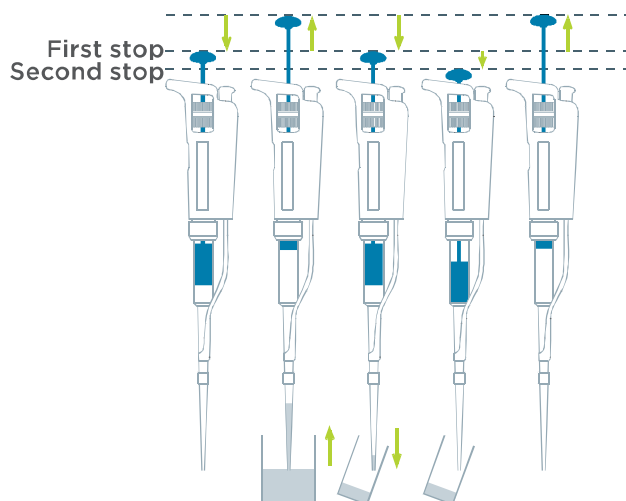
**Figure 9**

Pipetting Motion - Aspirate and Dispense





Dispense

- Place the end of the tip against the inside wall of the recipient vessel (at an angle of 10° to 40°).
- Press the push button slowly and smoothly to the **first stop**.
Wait for at least a second, then press the push button to the **second stop** to expel any residual liquid from the tip. Keep the push button pressed fully down and (while removing the pipette) draw the tip along the inside surface of the vessel.
- Release the push button smoothly. Eject the tip by pressing firmly on the tip ejector button.

Guidelines for Good Pipetting

- Make sure that you operate the push button slowly and smoothly.
- When aspirating, keep the tip at a constant depth below the surface of the liquid (refer to the table).

MODEL	IMMERSION DEPTH (MILLIMETERS)	WAIT TIME (SECONDS)
P2N	1	1
P10N	1	1
P20N	2-3	1
P100N	2-4	1
P200N	2-4	1
P1000N	2-4	2-3
P8x20N, P12x20N	2-3	1
P8x200N, P12x200N	2-3	1

- Change the tip before aspirating a different liquid, sample, or reagent.
- Change the tip if a droplet remains at the end of the tip from the previous pipetting operation.
- Each new tip should be pre-rinsed with the liquid to be pipetted.

- Liquid should never enter the tip holder; to prevent this:
 - press and release the push button slowly and smoothly,
 - never turn the pipette upside down,
 - never lay the pipette on its side when there is liquid in the tip.
- If you use the same tip with a higher volume, pre-rinse the tip.
- For volatile solvents you should saturate the air cushion in your pipette by aspirating and dispensing the solvent repeatedly before aspirating the sample.
- When the temperature of the liquid is different from the ambient temperature, pre-rinse the tip several times before use.
- You may remove the tip ejector (refer to [Changing the Tip Ejector](#) on page 18) to aspirate from very narrow tubes.

After pipetting acids or other corrosive liquids that emit vapors, remove the tip holder, rinse the piston, O-ring, and seal with distilled water. For the P1000N model, use a specific tip holder equipped with a filter to increase the lifetime of the piston (refer to [ACCESSORIES](#) on page 14).

- Do not pipette liquids with temperatures above 70°C or below 4°C. The pipette can be used between +4°C and +40°C but the specifications may vary according to the temperature (refer to the ISO 8655-2 standard for conditions of use).





Chapter 4

ACCESSORIES

To make pipetting more comfortable and more secure, Gilson has developed several accessories:

Pipette stands allow users to store pipettes vertically to avoid the possibility of liquid running back into the pipette.

DESCRIPTION	P/N
CARROUSEL™ pipette stand (7 pipettes)	F161401
TRIO™ stand (3 pipettes)	F161405
SINGLE™ pipette holder	F161406

To identify or personalize your pipette, Coloris™ clips are available:

DESCRIPTION	P/N
COLORIS™ clips (mixed colors set of 10)	F161301
COLORIS clips (red, set of 10)	F161302
COLORIS clips (yellow, set of 10)	F161303
COLORIS clips (green, set of 10)	F161304
COLORIS clips (blue, set of 10)	F161305
COLORIS clips (white, set of 10)	F161306

With The JIMMY™, a hands-free microtube opener, you can open both snap-cap and screw-cap microtubes.

DESCRIPTION	P/N
THE JIMMY™ (set of 3)	F144983

To protect the piston when pipetting corrosive liquids, you can use a specific tip holder and filter for the model P1000N:

DESCRIPTION	P/N
CORROSION PROTECTION KIT (TIP HOLDER + A BAG OF 10 FILTERS)	F144570
CORROSION PROTECTION KIT FILTER (BAG OF 10)	F144571
CORROSION PROTECTION KIT FILTER (BAG OF 50)	F144572

Chapter 5

TROUBLESHOOTING

A quick inspection of the pipette may help you to detect a problem.

NOTE

You may download the *2 Minute Inspection Poster* from the Gilson website (www.gilson.com), which shows how to perform a quick diagnosis of your pipette.

WARNING

Before returning any pipette to your local Gilson Service Center, ensure that it is completely free of chemical, biological, or radioactive contamination. Refer to [Cleaning and Decontamination](#) on page 21. Please use the included safety bag to return the pipette to your local Gilson Service Center.

Troubleshooting Table

The following table may help you to identify and correct the problem you might encounter.

SYMPTOM	POSSIBLE CAUSE	ACTION
Pipette is leaking sample	Damaged tip holder	Replace the tip holder*
	Worn O-ring or seal	Replace both parts*
Pipette won't aspirate	Worn O-ring	Replace both parts*
	Damaged tip holder	Replace the tip holder*
	Connecting nut is loose	Tighten connecting nut
	Damaged or corroded piston	Return pipette to supplier
	Improper repair or assembly	Refer to page 17 - MAINTENANCE





SYMPTOM	POSSIBLE CAUSE	ACTION
Pipette is inaccurate	Improper repair or assembly	Refer to page 17
	Unscrew tip holder	Tighten connecting-nut*
	Connecting nut is loose	Tighten connecting-nut*
Pipette is not precise	Tip holder is loose	Tighten connecting nut*
	Connecting nut is loose	Tighten connecting nut
	Incorrect operator technique	Operator training
	Damaged or corroded piston	Return pipette to supplier
	Damaged tip holder	Replace the tip holder*
	Worn O-ring or seal	Replace both parts*
Tips fall off or do not fit correctly	Low quality tips	Use PIPETMAN® DIAMOND tips
	Damaged tip holder	Replace the tip holder*
	Damaged tip ejector	Replace tip ejector
	Ejector spacer is missing	Mount the spacer on the tip ejector
	The ejector spacer is damaged	Replace the ejector spacer
	The tip ejector is loose	Assemble the tip ejector properly
	The ejector lock is misaligned	Align the ejector lock

*Not applicable for multichannel models.

However, if you can't solve the problem, contact your Gilson representative.

Leak Test

This test may be performed at any time to check that the pipette does not leak, especially after performing a maintenance or decontamination procedure. If a pipette fails this test, replace the O-ring and seal. After making sure that the pipette is correctly reassembled, repeat this test (not applicable to multichannel pipettes).

P2N to P200N, P8x20N, P12x20N, P8x200N, and P12x200N Models

1. Fit a PIPETMAN® DIAMOND tip.
2. Set the pipette to the maximum volume, given in the specifications, and pre-rinse.
3. Aspirate the set volume from a beaker of distilled water.
4. Maintain the pipette in the vertical position and wait for 20 seconds.
5. If a water droplet appears at the end of the tip, there is a leak.
6. If you see no droplet, re-immers the tip below the surface of water.
7. The water level inside the tip should remain constant; if the level goes down, there is a leak.

P1000N Models

1. Fit a PIPETMAN® DIAMOND tip.
2. Set the pipette to the maximum volume given in the specifications.
3. Aspirate the set volume from a beaker of distilled water.
4. Maintain the pipette in the vertical position and wait for 20 seconds.
5. If a water droplet appears at the end of the tip, there is a leak.

Chapter 6

MAINTENANCE

Routine maintenance will help keep your pipette in good condition, ensuring a continued high level of performance. Maintenance is limited to cleaning or autoclaving the parts specified under [Cleaning and Decontamination](#) on page 21 or to replacing the push button, connecting nut, tip ejector, tip holder, seal and O-ring.



**NOTICE**

PIPETMAN P2N and P10N should not be disassembled, so you may only replace the push button, tip ejector, dual position tip ejector and its adapter. With these pipettes if the tip holder is damaged, the piston may also be damaged.

For multichannel models, the lower part should not be disassembled: only the push button, the connecting nut and the the tip-ejector can be replaced.

After replacing any parts you should verify the performance of your pipette following the verification procedure available on the Gilson website (www.gilson.com). If the pipette needs to be readjusted, please contact your local Gilson authorized Service Center.

Single channel models

Changing the Tip-ejector

To remove

1. Push the ejection button.
2. Push laterally the tip-ejector.
3. Slide and remove the tip-ejector.

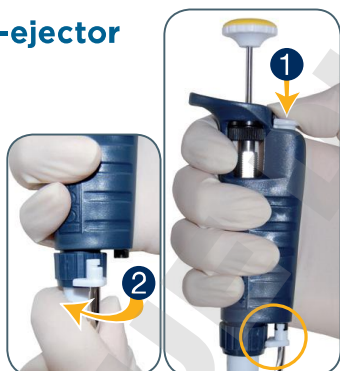

To refit

1. Push the ejection button.
2. Slide the tip-ejector along the tip-holder.
3. Clip the tip-ejector on the body of the pipette.

Changing the Tip-holder - no tools required

1. Remove the tip-ejector (see above).
2. Unscrew the connecting nut by turning it counter-clockwise.
3. Carefully separate the lower and upper parts.
4. Remove the piston assembly, O-ring and seal.
5. Clean, autoclave, or replace the tip-holder.

6. Reassemble the pipette (refer to Figure 10, page 19).
7. Tighten the connecting nut (turn clockwise).
8. Refit the tip-ejector (see above).

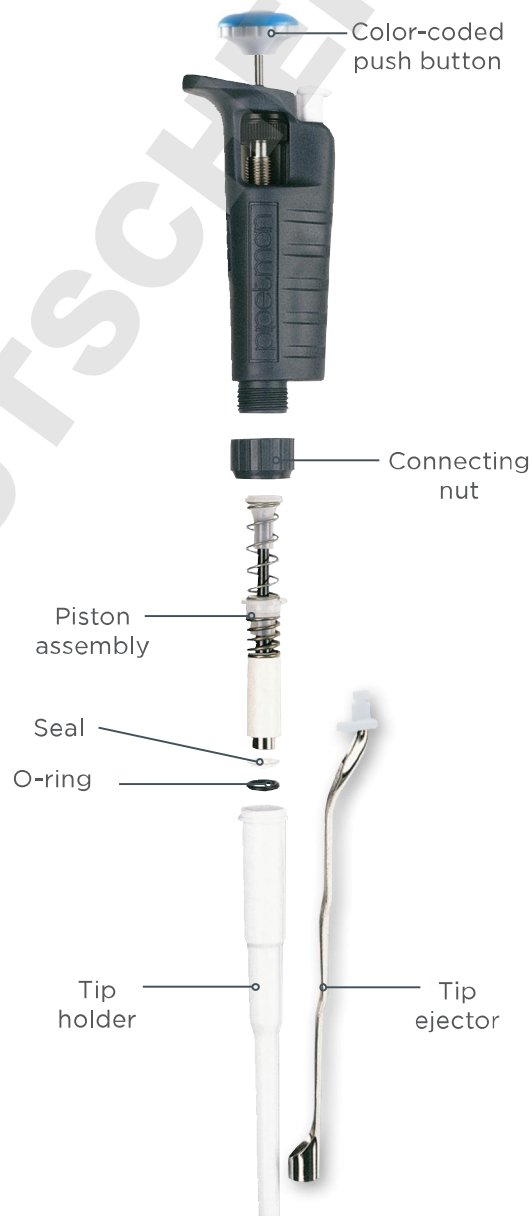

Figure 10
Piston Assembly (Disassembled)





Servicing the Piston Assembly

You may remove the piston assembly for cleaning purposes only. If the piston assembly is changed, the pipette must be adjusted and calibrated in a Gilson authorized Service Center.

WARNING

The piston assembly must not be autoclaved.

1. Remove the tip ejector (refer to [Changing the Tip Ejector](#) on page 18).
2. Unscrew the connecting nut by turning it counter-clockwise.
3. Carefully separate the lower and upper parts.
4. Remove the piston assembly, O-ring, and seal.
5. Clean and decontaminate the piston assembly.
6. Reassemble the pipette (refer to Figure 10, page 19).
7. Tighten the connecting nut (turn clockwise).
8. Refit the tip ejector (refer to [Changing the Tip Ejector](#) on page 18).

Changing the O-Ring

The O-ring and seal are on the piston; **they must not be autoclaved**, if worn or damaged in any way (chemical or mechanical), they must be replaced. The dimensions of the O-ring vary depending on the model of pipette.

1. Remove the tip ejector (refer to [Changing the Tip Ejector](#) on page 18).
2. Unscrew the connecting nut by turning it counter-clockwise.
3. Carefully separate the lower and upper parts.
4. Remove the piston assembly, O-ring and seal.
5. Clean or replace the seal then the O-ring.
6. Reassemble the pipette (refer to Figure 10, page 19).
7. Tighten the connecting nut (turn clockwise).
8. Refit the tip ejector (refer to [Changing the Tip Ejector](#) on page 18).

Multichannel models

Changing the Tip-ejector

1. To remove the tip-ejector, keep both ejector locks depressed.
2. Pull the tip-ejector down.
3. To refit the tip-ejector, gently re-insert the tip-ejector vertically into the rails of the ejector.
4. Pull lightly on the tip ejector to check the position.



Figure 11
Multichannel ejection system

Chapter 7

CLEANING & DECONTAMINATION

PIPETMAN Neo is designed so that the parts normally in contact with liquid contaminants, can easily be cleaned and decontaminated. However, because the models P2N and P10N contain miniaturized parts, it is best not to disassemble these pipettes yourself; please contact your local Gilson authorized service center.

NOTICE

You may refer to the decontamination procedure available on the Gilson website (www.gilson.com).

Liquid must never enter the upper part (handle) of any pipette.





Cleaning

The pipette must be cleaned, as described below, before it is decontaminated. Soap solution is recommended for cleaning PIPETMAN Neo.

SINGLE CHANNEL MODELS – EXTERNAL

1. Remove the tip ejector.
2. Wipe the tip ejector with a soft-cloth or lint-free tissue soaked with soap solution.
3. Wipe the entire pipette with a soft-cloth or lint-free tissue soaked with soap solution, to remove all dirty marks. If the pipette is very dirty, a brush with soft plastic bristles may be used.
4. Wipe the entire pipette and the tip ejector with a soft cloth or lint-free tissue soaked with distilled water.
5. Refit the tip ejector and allow the pipette to dry.

SINGLE CHANNEL MODELS – INTERNAL

The following components **only** can be immersed in a cleaning solution: connecting nut, tip ejector, tip holder, piston assembly, seal and O-ring.

1. Disassemble the pipette as described in [MAINTENANCE](#) on page 17.
2. Set aside the upper part in a clean, dry place.
3. Clean the individual components of the lower part of the pipette using an ultrasonic bath (20 minutes at 50°C) or with a soft-cloth and brushes. Small round brushes with soft plastic bristles may be used to clean the interior of the tip holder.
4. Rinse the individual components with distilled water.
5. Leave the parts to dry by evaporation or wipe them with a clean soft-cloth or lint-free tissue.
6. Reassemble the pipette as described in [MAINTENANCE](#) on page 17.

MULTICHANNEL MODELS

The following components **only** can be immersed in a cleaning solution: tip-ejector, ejector locks and ejector spacer.

1. Remove the tip-ejector and the ejector spacer.
2. Immerse the tip-ejector, ejector locks and ejector spacer in the cleaning solution or wipe them with a soft-cloth or lint-free tissue soaked with the cleaning solution.
3. Rinse the components with distilled water.
4. Wipe the entire pipette with a soft cloth or lint-free tissue soaked with the cleaning solution.
5. Wipe it with distilled water.
6. Leave the parts to dry by evaporation or wipe them with a clean soft-cloth or lint-free tissue.
7. Refit the tip-ejector as described in page 16 (Changing the tip-ejector).

Autoclaving

SINGLE CHANNEL MODELS

The upper part (body) and the piston assembly of the pipette are **not** autoclavable. **Only** the following parts may be autoclaved: tip ejector, tip holder and connecting nut. The O-ring and seal are **not** autoclavable; they may be cleaned or replaced with the one specified in [SPARE PARTS](#) on page 26.

1. Clean the parts to be autoclaved, especially the tip holder.
2. Put the parts in an autoclaving sack.
3. Autoclave for 20 minutes at 121°C, 0.1 MPa.
4. Check that the parts are dry before re-assembling the pipette.
5. Set the pipette aside to stabilize at room temperature.
6. Check the performance of your pipette.

MULTICHANNEL MODELS

The complete lower part can be autoclaved (20 minutes at 121°C, 0.1 MPa).

The lower part has to be removed from the body.



**To remove:**

1. While pressing down on the tip-ejector button, turn the ejector clip counter-clockwise to separate it from the handle.
2. Unscrew the connecting nut turning counter-clockwise.
3. Press push button to extract the head.

**To autoclave:**

1. Clean the parts to be autoclaved, especially the tip holders and the ejector spacer.
2. Put the lower part in an autoclaving sack.
3. Autoclave for 20 minutes at 121°C, 0.1 MPa.
4. Check that the autoclaved part is dry before re-assembling the pipette.
5. Set the pipette aside to stabilize at room temperature.
6. Check the performance of your pipette.

To fit the lower part on the body:

1. Press the pushbutton.
2. Insert the lower part into the ejection rod. Release the push button.
3. Screw the connecting nut turning clockwise.
4. Press the tip-ejector button.
5. Insert the ejector clip and then release the tip-ejector button.

**Chemical Decontamination**

You may choose to decontaminate your pipette chemically, in accordance with your own procedures.

Whatever decontaminant you use, check with the supplier of the decontaminant that it is compatible with stainless steel and the plastics used in the construction of the pipette: PA (Polyamide), PBT (Polybutylene Terephthalate), PC (Polycarbonate), PC/PBT (Polycarbonate/Polybutylene Terephthalate), POM (Polyoxymethylene), or PVDF (Polyvinylidene Fluoride).

UPPER PART (HANDLE)

1. Wipe the upper part (handle) of the pipette with a soft-cloth or lint-free tissue soaked with the chosen decontaminant.
2. Wipe the upper part of the pipette with a soft cloth or lint-free tissue soaked with distilled water or sterile water.

SINGLE CHANNEL – LOWER PART (VOLUMETRIC MODULE)

The following components **only** can be immersed in a decontaminant solution: connecting nut, tip ejector, tip holder, piston assembly, seal and O-ring.

MULTICHANNEL – LOWER PART (VOLUMETRIC MODULE)

The following components **only** can be immersed in a cleaning solution: tip-ejector, ejector locks and ejector spacer.

1. Remove the tip-ejector and the ejector spacer.
2. Immerse the tip-ejector, ejector locks and ejector spacer in the cleaning solution or wipe them with a soft-cloth or lint-free tissue soaked with the cleaning solution.
3. Rinse the components with distilled water.
4. Wipe the entire pipette with a soft cloth or lint-free tissue impregnated with the cleaning solution.
5. Wipe it with distilled water.
6. Leave the parts to dry by evaporation or wipe them with a clean soft-cloth or lint-free tissue.
7. Refit the tip-ejector as described in page 16 (Changing the tip-ejector).





Chapter 8

SPARE PARTS

Cleaning

- ▶ Service Kit 1st level includes:
 - Three piston seals
 - Three O-rings
 - One tip holder
- ▶ Service Kit 2nd level includes:
 - One push button
 - One connecting nut
 - One tip ejector
- ▶ or only for the P2N and P10N models
 - One tip ejector
 - One adapter

(Refer to Figure 12, page 28)

P2N (F144561) and P10N (F144562)

LABEL	DESCRIPTION	P2N	P10N
C+D+E	Service Kit 1st level	F144501	F144502
A+B+F1+F2	Service Kit 2nd level	F161970	F161971
C+D	Seal + O-Ring (5 sets)	F144861	F144862
F2	Tip Ejector Adapter	F144879	F144879

P20N (F144563) and P100N (F144564)

LABEL	DESCRIPTION	P20N	P100N
C+D+E	Service Kit 1st level	F144495	F144496
A+B+F	Service Kit 2nd level	F161972	F161973
C+D	Seal + O-ring (5 sets)	F144863	F144864

P200N (F144565) and P1000N (F144566)

LABEL	DESCRIPTION	P200N	P1000N
C+D+E	Service Kit 1st level	F144497	F144498
A+B+F	Service Kit 2nd level	F161974	F161978
C+D	Seal + O-ring (5 sets)	F144865	F144866

P8x20N (F14401) and P12x20N (F14402)

LABEL	DESCRIPTION	P8X20N	P12X20N
F3-F4	Tip ejector	F507005	F507006
G	Ejector lock	F507008	F507008
H1-H2	Ejector spacer	F507001	F507003

P8x200N (F14403) and P12x200N (F14404)

LABEL	DESCRIPTION	P8X200N	P12X200N
F3-F4	Tip ejector	F507005	F507006
G	Ejector lock	F507008	F507008
H1-H2	Ejector spacer	F507001	F507003





Single channel models

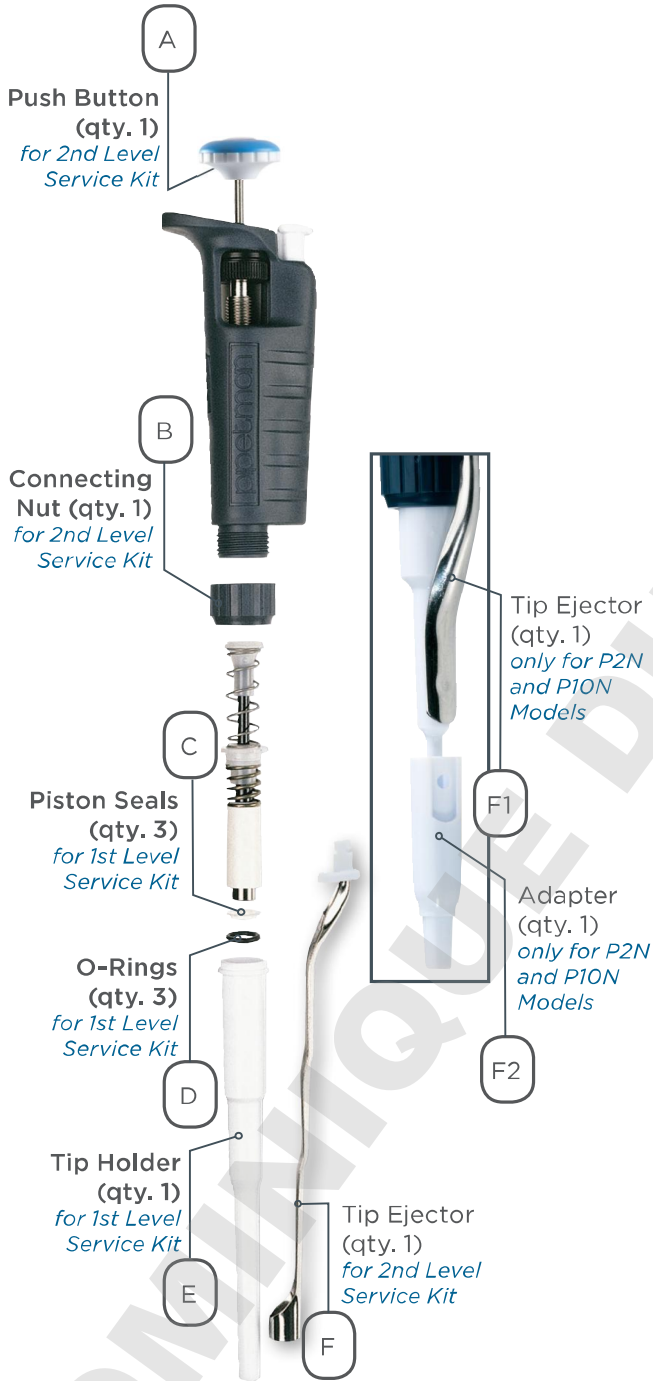

Multichannel models

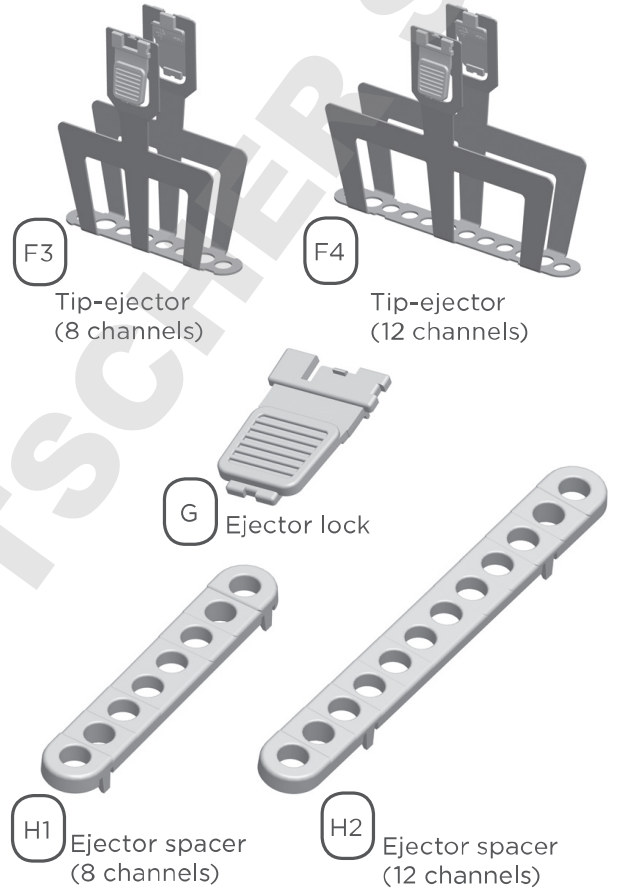

Figure 12

Spare Parts Identified



www.gilson.com/contactus

Gilson, Inc.

3000 Parmenter Street • PO Box 620027
Middleton, WI 53562 USA
T: 608-836-1551 or 800-445-7661 • F 608-831-4451

Gilson S.A.S.

19, avenue des Entrepreneurs BP 145 • F-95400
Villiers-le-Bel, France
T +33 (0) 1 34 29 50 00 • F +33 (0) 1 34 29 50 20

LT801521/F | ©2017 Gilson, Inc. All rights reserved.