

# WHEATON®

## CryoELITE® Tissue Vial

### Sample Integrity



The WHEATON CryoELITE Tissue Vial is for those who value sample integrity, designed specifically for tissue collection, transport and storage to provide the utmost protection. Different from cells and biofluids, tissue specimens have particular requirements for cryogenic storage (see the WHEATON blog at [www.CryoFeed.com](http://www.CryoFeed.com) for more information). Offering researchers a uniform vial able to maintain sample integrity while maximizing storage capacity and organization, the WHEATON CryoELITE Tissue Vials feature a wide-mouth opening, 5mL capacity and high integrity closure. The CryoELITE Tissue Vial offers researchers who work with tissue samples ease of use, convenience and security.

CryoELITE Tissue Vials are manufactured from low binding, cryogenic-grade virgin polypropylene that meets the USP Class VI classification. Lot tested and certified to be free of pyrogens, RNase / DNase and endotoxins, the vials have a sample capacity of 5mL and a storage temperature range of -156°C to 121°C. The externally threaded cap provides a seal that exceeds DOT and IATA classifications for diagnostic specimens and their transport and is capable of maintaining a secure closure during freeze/thaw procedures. The vials have a flat bottom and a stippled external surface to promote easier handling.

The WHEATON CryoELITE Tissue Vial is for those who value sample integrity, designed specifically for tissue collection, transport and storage to provide the ultimate protection. When your decision depends on sample integrity... Trust that specimen to a WHEATON CryoELITE Tissue Vial.

#### Product Highlights

<ul style="list-style-type: none"><li>• CryoELITE Tissue Vials unrivaled cap seal exceeds DOT and IATA regulations ensuring ultimate protection of samples during transportation and demanding freeze-thaw handling.</li></ul>	<ul style="list-style-type: none"><li>• CryoELITE Tissue Vials are made from low binding, cryogenic grade virgin polypropylene. They are lot certified RNase / DNase and Endotoxin free providing assurance of product integrity.</li></ul>
<ul style="list-style-type: none"><li>• CryoELITE Tissue Vials offer uniform, secure storage for maximal organization and management of your precious biospecimens.</li></ul>	<ul style="list-style-type: none"><li>• Due to uniform size and availability of CryoFile® Storage Boxes, CryoELITE Tissue Vials easily integrate into your current storage system.</li></ul>
<ul style="list-style-type: none"><li>• Directional indicators on secure stop rim allow orientation of tissue within vial.</li></ul>	<ul style="list-style-type: none"><li>• 5mL freestanding, externally threaded vials; packaged into sterile bags of 25. Each case contains 10 bags.</li></ul>

# SPECIFICATIONS

## CryoELITE® Tissue Vial Storage Boxes



### Features

- Use for batching and storing cryogenic tissue vials
- 2 boxes can be stacked in a standard 2" freezer rack, allowing for storage of 50 vials in standard racks.
- Partitions numbered 1-25 for easy content identification
- Six colors provide easy sample identification
- Water repellent material allows for longer durability
- Withstands cryogenic temperatures to -196°C
- CryoFile® Tissue Box Dimensions (LxWxH): 130 x130x 5mm
- Product Number: W651610-W, R, P, Y, G, B

CryoELITE Technical Information	
Material	Made from low binding, cryogenic grade virgin polypropylene
Temperature Range	-196°C to +121°C
Sterility	Lot Certified Sterile, Radiation Sterilization
DNase / RNase Free	Lot Certified, Ethidium Bromide (EtBr) Agarose Gel Electrophoresis Analysis
Non-Pyrogenic, Endotoxin Free	Lot Certified < 0.500 EU/mL (Kinetic Turbidimetric LAL Method, FDA guideline)
Seal psi	Exceeds 15 psi / 1 atmosphere / 95kPa pressure tested
IATA (International Air Transportation Association)	Can be used as a primary receptacle for the Transport of Diagnostic Specimens as outlined by the IATA Dangerous Goods Regulations, Part 6.3,5
DOT (U.S. Department of Transportation)	Exceeds U.S. DOT 49 CFR Parts 171-180 requirements for Diagnostic Specimen Packing and Transportation Requirements
Liquid Nitrogen	Liquid phase tested / Vapor phase accepted
Autoclavable	Recommended at +121°C, 15 psi (1 bar) for 20 minute
	Product is CE compliant to The European In Vitro Diagnostic Medical Devices Directive 98/79/EC

### Technical Specifications

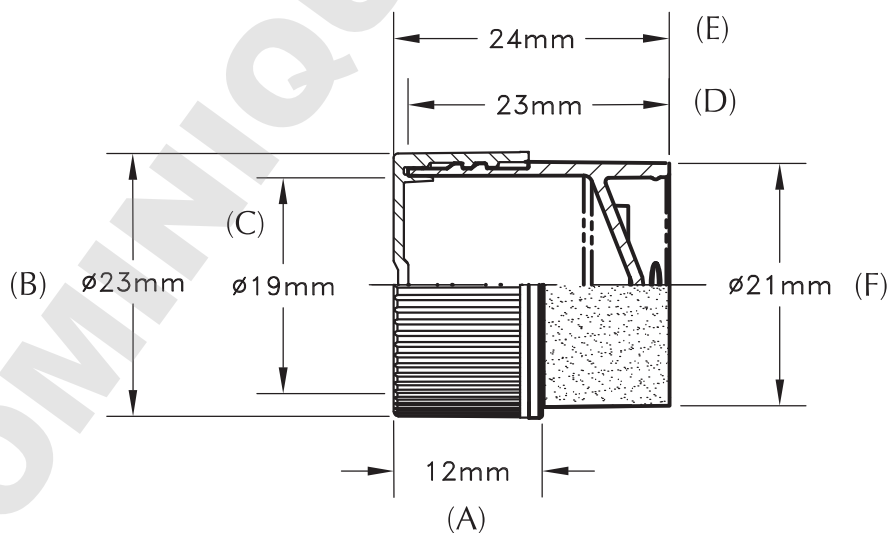

5mL FS Ext	
A	Cap Height
B	Overall OD
C	Vial ID
D	Vial Height
E	Overall Height
F	Body OD