

# User Guide

## **MultiScreen<sup>®</sup>** HTS **384-Well Plates**

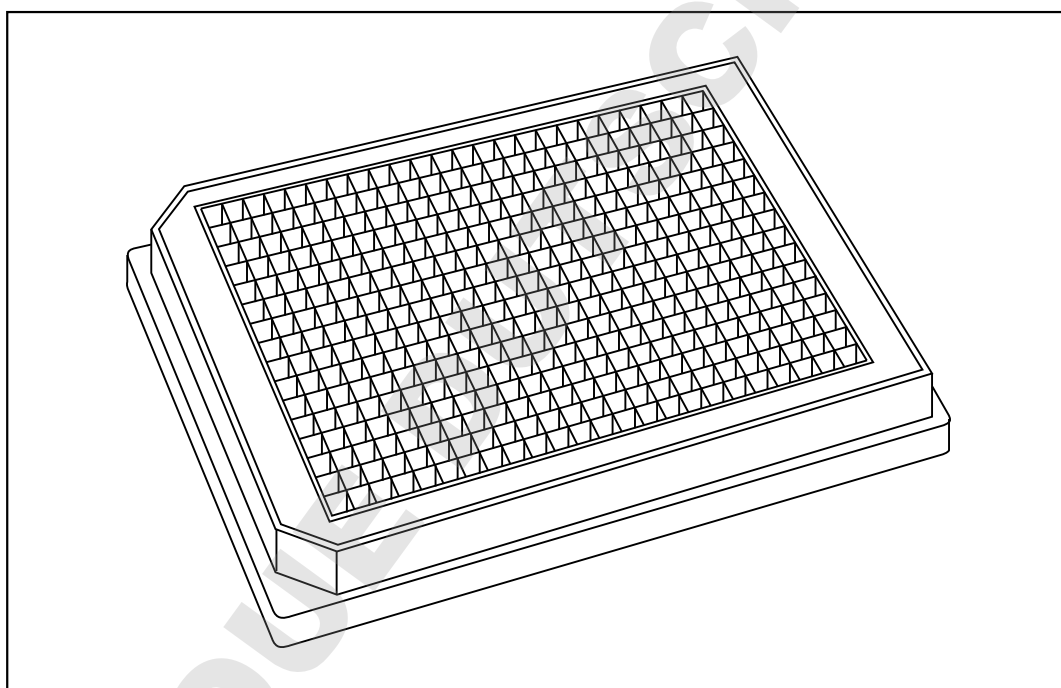

**For use in automated high throughput applications  
including sample preparation and  
radiometric filter-binding assays**

For research use only  
Single use only

**MILLIPORE**

## **Notice**

The information in this document is subject to change without notice and should not be construed as a commitment by Millipore Corporation. Millipore Corporation assumes no responsibility for any errors that may appear in this document. This manual is believed to be complete and accurate at the time of publication. In no event shall Millipore Corporation be liable for incidental or consequential damage in connection with or arising from the use of this manual.

Copyright 2006, Millipore Corporation. All rights reserved.

Millipore, Durapore, and MultiScreen are registered trademarks of Millipore Corporation.

MicroBeta is a registered trademark of Wallac OY.

MicroScint is a registered trademark of Optoscint, Inc.

Opti-Fluor and MicroScint-O are trademarks of Packard Instrument Company, Inc.

OptiPhase is a trademark of Fisons Chemicals.

Supermix is a trademark of Wallac Instruments

Tween is a registered trademark of Atlas Powder Company.

Ultima Gold is a trademark of PerkinElmer, Inc.

PR02335, Rev. A, 12/06

# Contents

Introduction .....	1
Diagram of MultiScreen <sub>HTS</sub> 384-well Filter Plate with Lid .....	1
Materials Required .....	2
Chemical Compatibility .....	3
Usage Guidelines .....	4
Limitations .....	5
Procedure .....	5
Sample Addition .....	5
In-Plate Incubation .....	5
Sample Filtration .....	6
Filtrate Collection .....	6
Filtrate Transfer to Waste .....	6
Automated Operation Guidelines .....	7
Radiometric Assay Counting Guidelines .....	7
Whole Plate Scintillation Counting .....	7
Radioisotope Guidelines .....	8
Specifications .....	8
Product Ordering Information .....	9
Technical Assistance .....	10
Standard Warranty .....	11

## Introduction

MultiScreen<sub>HTS</sub> 384-well plates are non-sterile, single use filter plates that can be used to perform high throughput biological assays or to prepare samples for subsequent analysis. The filter plate can be used in a variety of biological assays including receptor-ligand binding (RLB) assays, assays that measure enzyme activity (e.g., kinases, phosphatases, proteases, etc.), and general sample prep.

The MultiScreen<sub>HTS</sub> 384-well plate is designed to be compatible with robotic workstations for automated manipulation and can be used with either vacuum or centrifugal filtration modes. These filter plates are compatible with 384-well receiver plates for the collection and analysis of filtered samples.

### Diagram of MultiScreen<sub>HTS</sub> 384-well Filter Plate with Lid

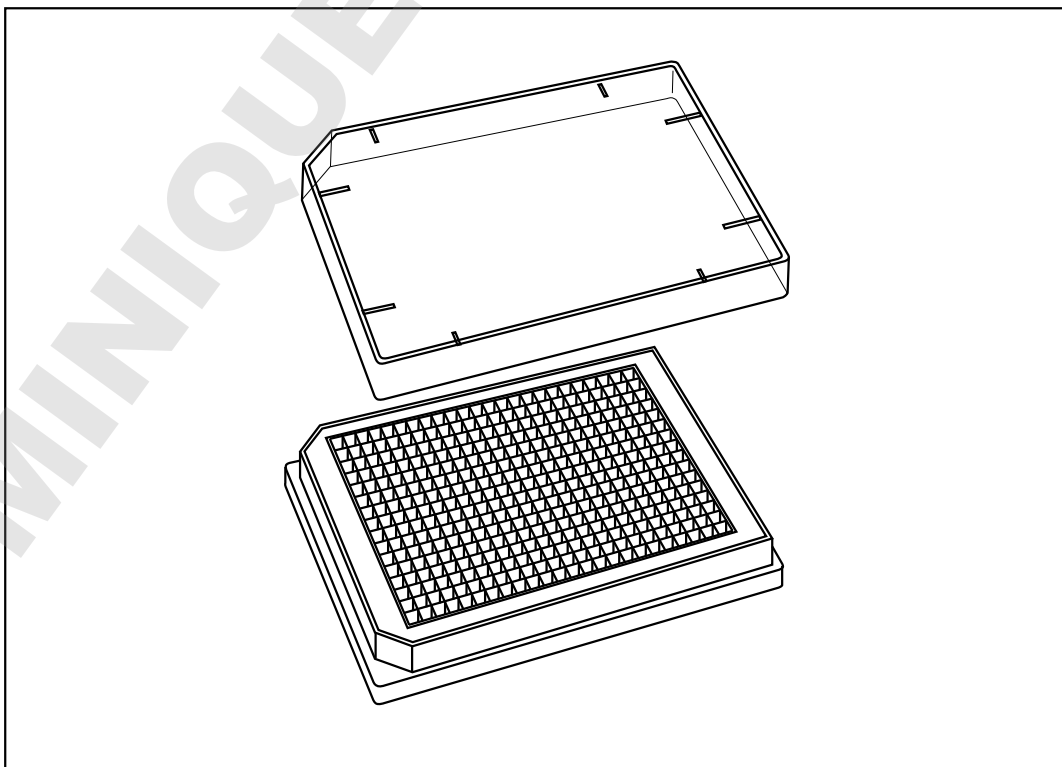

## Materials Required

The user must supply the following materials in order to use the MultiScreen<sub>HTS</sub> 384-well filter plate:

### Reagents:

- Application-appropriate aqueous buffers, biological components, and other assay materials

### Equipment:

- Manual pipettors or robotic liquid handling systems for transferring of liquid into filter plates
- Vacuum manifold (Millipore cat. no. MSVM HTS 00) or centrifuge with a swinging bucket rotor and multiwell plate carrier
- Solid bottom 384-well assay plates (if collecting filtrate)

## Chemical Compatibility

R= Resistant, N= Non-Resistant, T= User should test in application

Chemical	Compatibility	
	Membrane	Glass/Paper
<b>Acids</b>		
Acetic Acid (Glacial)	N	N
Acetic Acid (25%)	R	R
Sulfuric Acid (90%)	N	N
<b>Scintillants</b>		
MicroScint-O™ Scintillant	R	R
MicroScint® 40 Scintillant	R	R
Opti-Fluor® Scintillant	R	R
OptiPhase™ Supermix™ Scintillant	N	R
Ultima Gold™ Scintillant	R	R
<b>Organic Solvents</b>		
Acetone	N	N
Acetonitrile	N	N
Tetrahydrofuran	N	N
Diethyl Ether	N	N
DMSO	N	N
Glycerol	R	R
Methanol	T	T
<b>Aqueous Solvents</b>		
Sodium Dodecyl Sulfate (SDS)	R	T
Tween® Surfactant	R	T
Phosphate Buffered Saline (PBS)	R	R
1% Phosphoric Acid	R	R
1 N HCl	R	R
1 N NaOH	R	R
Acetonitrile (35%)	N	N
DMSO (5%)	R	R

## Usage Guidelines

- The MultiScreen<sub>HTS</sub> 384-well filter plate can be operated either in a vacuum or centrifugal pressure mode at temperatures between 4 °C and 37 °C. Recommended vacuum pressure is 8–15" Hg for glass fiber plates and membrane plates or 4–8" Hg for PH plates. Recommended centrifugal force is 500–1000 × g.
- In either vacuum or centrifugal mode, samples can be collected in a solid bottom receiver (assay) plate. In vacuum mode, sample or (wash) buffer(s) can be collected into a solid bottom receiver plate or transferred directly to waste.
- Although the MultiScreen<sub>HTS</sub> 384-well plate has been validated for use with extended incubations of aqueous media and scintillants, care should be taken to protect working surfaces from contamination in case of leakage.
- When doing radiometric in-plate analysis with the Wallac MicroBeta<sup>®</sup> TriLux liquid scintillation counter, plate carriers should be taped.
- Extended incubations with solutions containing high levels of surfactant may lead to drip out; test the plate before use in experiments.
- The MultiScreen<sub>HTS</sub> 384-well filter plate with glass fiber is compatible with polyethyleneimine (0.5% PEI) pretreatment. **Do not allow PEI to dry!** For those applications requiring this step, wash twice with binding buffer to complete preparation of plates after initial pretreatment for 2–16 hours at 4 °C.
- Dry glass fiber plates after filtration if adding scintillant. Do not dry PH or DEAE plates if adding scintillant. After adding scintillant, wait at least 1 hour before reading to allow scintillant to fully coat the filter.
- Cover the plate with the lid while incubating or use some other means to reduce evaporation, especially if incubating for more than 1 hour or at elevated temperatures.
- If incubating a reaction in PH plates, do not exceed 80 µL of sample per well.

## Limitations

Operating Temperature Range	4–37 °C
Maximum Drying Temperature	50 °C
Maximum Vacuum Pressure	20" Hg
Maximum Centrifugal Force	1000 × g

## Procedure

The following sections outline the use of the MultiScreen<sub>HTS</sub> 384-well filter plate.

### Sample Addition

Pipette the appropriate amount of test sample, 1 to 100 µL, into each well of the filtration plate. For best results when adding multiple solutions to the well, add the solution with the largest volume first, and end by adding the solution containing the smallest volume. Well volume limit is 80 µL for PH plates.

### In-Plate Incubation

The MultiScreen<sub>HTS</sub> 384-well filter plate is designed to permit in-plate incubations of various liquids, thereby eliminating the need to perform assays in a separate plate prior to transferring the sample to the filter plate. Due to the low volumes typically incubated in the MultiScreen<sub>HTS</sub> 384-well filter plate (20–100 µL), it is recommended that the plate lid be used during extended incubations or incubations that are carried out at elevated temperatures (e.g., at or above 37 °C). Well volume limit is 80 µL for PH plates.



## Sample Filtration

Samples can be filtered using either centrifugal or vacuum modes. In centrifugal mode, a 384-well receiver plate is positioned under the filter plate to collect the filtrate. Vacuum filtration should be performed using the MultiScreen<sub>HTS</sub> Vacuum Manifold (Millipore cat. no. MSVM HTS 00). Please see the MultiScreen<sub>HTS</sub> Vacuum Manifold User Guide (P36530) for specific guidelines. In vacuum mode, the filtrate is either collected in a receiver plate or it is transferred directly to waste.

## Filtrate Collection

The filter plate is designed to be used in conjunction with an SBS/ANSI solid bottom 384-well receiver (assay) plate. When stacked on top of a 384-well receiver plate, the MultiScreen<sub>HTS</sub> 384-well plate will direct the contents of each well into the corresponding well in the receiver plate.

For centrifugation, stack the filter plate on top of a receiver plate and then place the assembly into the plate carrier of any standard centrifuge with swinging bucket rotors.

In vacuum mode, stack the filter plate on top of the receiver plate and place the assembly in the base of the vacuum manifold. The collar fits over the assembly. See the MultiScreen<sub>HTS</sub> Vacuum Manifold User Guide for details.

**NOTE:** Optimal vacuum levels can vary among assays.

Typically, the lowest vacuum setting that gives the desired performance should be used.

## Washing of Samples to Waste

For optimal performance during multiple washes of retentate sample (i.e., flow to waste), vacuum pressures of 12–15" Hg are recommended, depending on filter type.

## Automated Operation Guidelines

The MultiScreen<sub>HTS</sub> 384-well filter plate is designed to be used with automated liquid handling systems and robotic workstations that are compatible with ANSI/SBS standard 384-well plates. Integration of vacuum filtering capability may require some customization or be impossible on some systems. For the latest automation protocols and robotic workstation-specific programs and instruction, please see: <http://www.millipore.com/automation>.

## Radiometric Assay Counting Guidelines

Follow the guidelines below for in-plate measurement of radioactivity. For information on receptor ligand binding assays or kinase assays, go to [www.millipore.com/publications](http://www.millipore.com/publications).

### Whole Plate Scintillation Counting

Radioactivity (scintillation counting) can be measured directly in the MultiScreen<sub>HTS</sub> 384-well filter plate. The design allows the plate to be analyzed from the top (top counting), from the bottom (bottom counting), or from both sides simultaneously (coincidence counting). For best signal to noise ratios using the Wallac MicroBeta TriLux liquid scintillation counter, count in the coincidence mode. Scintillation counting should be performed after at least one hour of exposure to the liquid scintillant cocktail. In some instances, longer incubations (up to 24 hours) may result in even higher counting efficiencies. Because different assays have different counting criteria and levels of signal, optimum counting mode and time should be determined by the operator.

## Radioisotope Guidelines

Low energy isotopes such as  $^{14}\text{C}$ ,  $^3\text{H}$ ,  $^{125}\text{I}$ ,  $^{33}\text{P}$ , and  $^{35}\text{S}$  require the use of 5–10  $\mu\text{L}$  of scintillation cocktail per well. For optimal results and consistency, the scintillation cocktail should be allowed to mix with the sample for at least an hour before counting. This time is required to allow for complete mixing of the radiolabeled materials into the scintillation cocktail.

## Specifications

Materials of construction:

Base plate	Styrene Acrylonitrile (SAN) top: white; bottom: clear
Plate lid	Polystyrene
Support	Polyester (glass fiber and filter paper only)
Membrane	PVDF

*See Product Ordering Information table for filter types.*

Dimensions:

Plate assembly length	127.8 mm
Plate assembly width	85.5 mm
Plate assembly depth (without lid)	14.4 mm
Plate assembly depth (with lid)	16.9 mm
Approximate filter surface area	0.09 $\text{cm}^2$
Well depth	approx. 10.9 mm

Recommended sample volume per well: 20–100  $\mu\text{L}$

Filtration parameters:

Recommended vacuum pressure	8–15" Hg for glass fiber and membrane plates 4–8" Hg for PH plates
-----------------------------	--

Recommended centrifugal force 500–1000  $\times g$

## Product Ordering Information

Catalog Numbers	Membrane/Filter Type	Qty
MZHV N0W 10	Hydrophilic 0.45 µm Durapore® PVDF	10/pk
MZHV N0W 50	Hydrophilic 0.45 µm Durapore PVDF	50/pk
MZFB N0W 10	Glass Fiber B	10/pk
MZFB N0W50	Glass Fiber B	50/pk
MZFC N0W 10	Glass Fiber C	10/pk
MZFC N0W 50	Glass Fiber C	50/pk
MZPH N0W 10	Phosphocellulose	10/pk
MZPH N0W 50	Phosphocellulose	50/pk

### Accessories

Description	Catalogue No.
MultiScreen <sub>HTS</sub> Vacuum Manifold	MSVM HTS 00
Chemical Duty Pump	
115 Volts, 60 Hz	WP61 115 60
220 Volts, 50 Hz	WP61 220 50
Spout Liner for Scintillation Counting	MZMB NCL 50
Plate Sealing Tape, 100 sheets	
Clear	MATA HCL 00
White	MATA HOP 00
Vacuum Flask, 1L	XX10 047 05

## Technical Assistance

For more information, contact the Millipore office nearest you. In the U.S., call **1-800-MILLIPORE** (1-800-645-5476). Outside the U.S., see your Millipore catalogue for the phone number of the office nearest you or go to our web site at [www.millipore.com/offices](http://www.millipore.com/offices) for up-to-date worldwide contact information. You can also visit the tech service page on our web site at <http://www.millipore.com/techservice>.

## Standard Warranty

**Millipore Corporation** (“Millipore”) warrants its products will meet their applicable published specifications when used in accordance with their applicable instructions for a period of one year from shipment of the products. **MILLIPORE MAKES NO OTHER WARRANTY, EXPRESSED OR IMPLIED. THERE IS NO WARRANTY OF MERCHANTABILITY OR FITNESS FOR A PARTICULAR PURPOSE.** The warranty provided herein and the data, specifications and descriptions of Millipore products appearing in Millipore's published catalogues and product literature may not be altered except by express written agreement signed by an officer of Millipore. Representations, oral or written, which are inconsistent with this warranty or such publications are not authorized and if given, should not be relied upon.

In the event of a breach of the foregoing warranty, Millipore's sole obligation shall be to repair or replace, at its option, the applicable product or part thereof, provided the customer notifies Millipore promptly of any such breach. If after exercising reasonable efforts, Millipore is unable to repair or replace the product or part, then Millipore shall refund to the customer all monies paid for such applicable product or part. **MILLIPORE SHALL NOT BE LIABLE FOR CONSEQUENTIAL, INCIDENTAL, SPECIAL OR ANY OTHER DAMAGES RESULTING FROM ECONOMIC LOSS OR PROPERTY DAMAGE SUSTAINED BY ANY CUSTOMER FROM THE USE OF ITS PRODUCTS.**

DOMINIQUE DUTSCHER SAS

MILLIPORE