



Non-Sterile 25 mm Millex[®] Syringe Filter Units -LG, -LCR, -HV, -GN, -HN

Automation Compatible (AC)
and
High Particulate Filtration (HPF)

- Do not use if packaging is damaged
- Do not use with syringes smaller than 10 cc
- For laboratory use only
- Single use only



Notice

The information in this document is subject to change without notice and should not be construed as a commitment by Millipore Corporation or an affiliated corporation. Neither Millipore Corporation nor any of its affiliated corporations assumes responsibility for any errors that may appear in this document. This manual is believed to be complete and accurate at the time of publication. In no event shall Millipore Corporation or an affiliated corporation be liable for incidental or consequential damage in connection with or arising from the use of this manual.

Copyright 2008, Millipore Corporation. All rights reserved.

Millipore, Durapore, and Millex are registered trademarks of Millipore Corporation.

The M mark is a trademark of Millipore Corporation.

Freon is a registered trademark of E. I. du Pont de Nemours and Company.

Luer-Lok is a trademark of Becton, Dickinson & Company.

Cellosolve is a registered trademark of Union Carbide Chemicals & Plastics Technology Corporation.

PR02862, Rev. B, 08/08

Introduction

This document provides chemical compatibility information, operating steps, and specifications for the 25 mm Millex Automation Compatible (AC) and High Particulate Filtration (HPF) syringe filters with male Luer-slip outlet. These filter units are non-sterile, single use, and disposable.

The filter consists of a membrane and/or prefilter in a high density polyethylene housing. For details on the type of membrane in your Millex syringe filter, see the “Specifications” section. The 25 mm size is recommended for filtering 10–100 milliliter (mL) volumes to remove particles prior to instrumentation analysis.

Introduction, continued

Filter Unit	Membrane	Use to...
LG	0.2 μm PTFE	Clarify protein-containing solutions, as well as aqueous or mild organic solutions.
LCR	0.45 μm PTFE	Clarify protein-containing solutions, as well as aqueous or mild organic solutions.
HV	0.45 μm PVDF	Clarify protein-containing solutions, as well as aqueous or mild organic solutions.
GN	0.2 μm Nylon	Remove fine particles from aqueous or organic solutions.
HN	0.45 μm Nylon	Clarify aqueous or organic solutions.

Chemical Compatibility

The 25 mm Millex AC and HPF syringe filters with male Luer-slip outlet are compatible with aqueous, mild organic, and organic solutions. Millex filter units can be used to filter the agents listed in the following chart. This information was developed from technical publications, materials suppliers, laboratory tests, and field evaluations, etc., and is believed to be accurate and reliable. However, because of variability in temperature, concentrations, exposure time, and other factors outside of our control that may affect the use of the unit, Millipore does not provide or imply a warranty with respect to such information. Millipore recommends that you test the 25 mm Millex AC and HPF syringe filters with agents that are not listed in the chart before using them.

Chemical Compatibility, continued

Chemical			
Acetic acid, glacial	Cyclohexane	Hydrogen	Paraldehyde
Acetic acid (5%)	Ethers	Hydrogen peroxide (3%)	PET base oils
Amyl acetate	Ethyl acetate	Isobutyl alcohol	Perchloroethylene
Amyl alcohol	Ethylene glycol	Isopropyl acetate	Phenol (10%)
Benzene	Formaldehyde	Kerosene	Silicone oils
Benzyl alcohol	Freon [®] TF or	MEK	Sulphuric acid (3N)
Brine (sea water)	PCA solvent	MIBK	Toluene
Boric acid	Gasoline	Mineral spirits	Trichloroethane
Butyl alcohol	Glycerine (Glycerol)	Nitrobenzene	Trichloroethylene
Carbon tetrachloride	Helium	Nitrogen	TFA
Cellosolve [®] solvent	Hydrochloric acid ¹	Ozone	THF
	Hydrochloric acid	(10 ppm in water)	Xylene

¹ Hydrochloric acid (6N) not compatible with GN and HN

Chemical Compatibility, continued

The 25 mm Millex AC and HPF syringe filters can be used to filter the agents listed in the chart below for low extractable HPLC instrumentation analysis applications.

NOTE: Millipore recommends either discarding the first 1 mL or rinsing the filter unit with 1 to 2 mL of primary solvent before sample filtration.

Chemical		
Acetonitrile	Dioxane	Methyl alcohol
Chloroform	Ethyl alcohol	Methylene chloride
Dimethylacetamide ¹	Hexane	Pentane
Dimethylformamide ¹	Isopropyl alcohol	Petroleum ether

¹ Chemical not compatible with HV

How to Use the 25 mm Millex AC and HPF Syringe Filters

This section lists the warnings and cautions and provides steps to use the 25 mm Millex syringe filter with male Luer-slip outlet.

▲ WARNING: Do not use the 25 mm Millex syringe filter for direct patient care applications; they are designed for laboratory use only.

CAUTIONS:

- To ensure proper filtration, do not use the 25 mm Millex syringe filters at temperatures above 45 °C (113 °F).
- Do not use syringes smaller than 10 cc; the pressure generated in these syringes may exceed the 125 psig limit of the Millex filter.
- Do not use the 25 mm Millex unit to filter a protein-containing solution without first evaluating whether the sample will bind to the filter.
- Do not reuse the 25 mm Millex filter.

Directions for Using the 25 mm Millex AC and HPF Filter Units

1

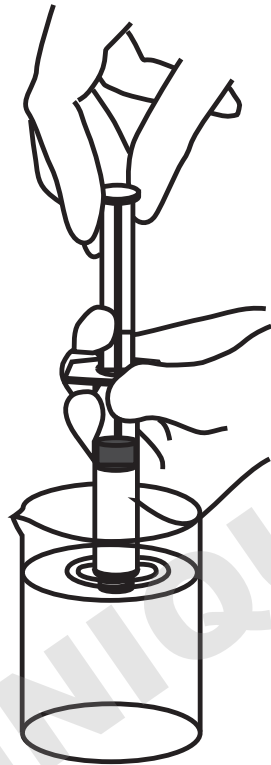

Fill the syringe with the solution to be filtered.

2

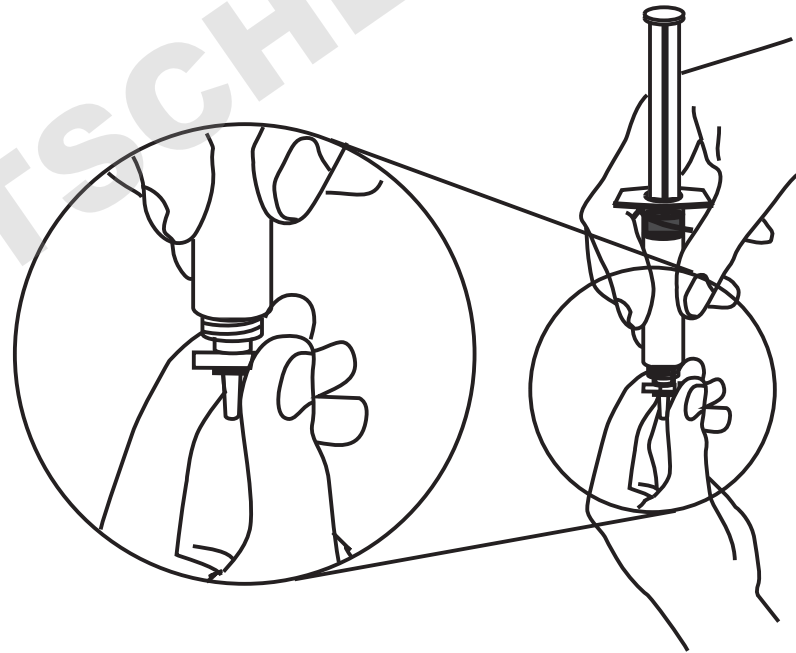

Attach the syringe to the 25 mm Millex filter.

continued

Directions for Using the 25 mm Millex AC and HPF Filter Units

3

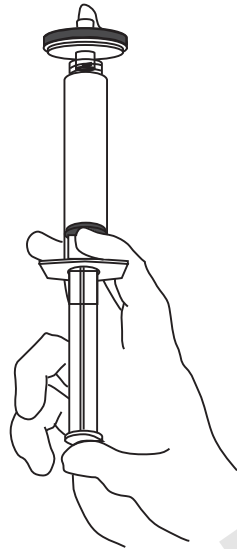

Hold the syringe with filter pointing up and “top off” by pushing a few drops through the filter.

4

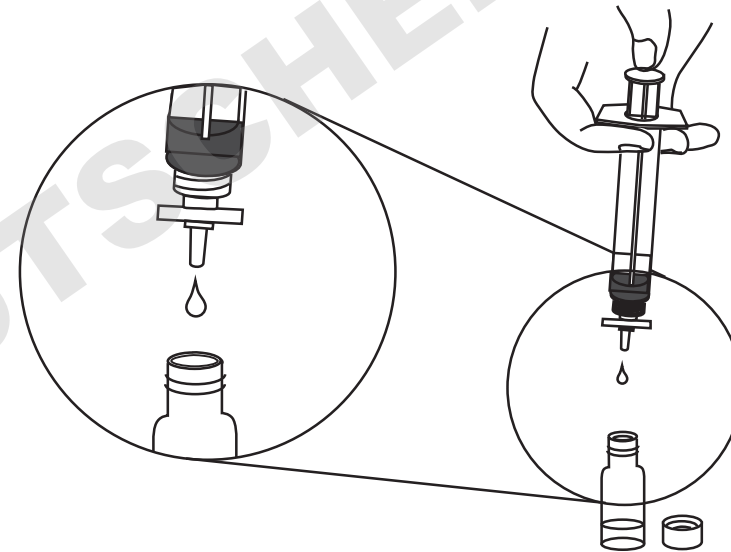

Push the syringe plunger to deliver a filtered solution.

Optional: To purge the unit and maximize sample throughput, remove the Millex filter from the syringe, draw air into the syringe, reattach the Millex filter, and push the plunger to force some of the air through the filter.

Specifications

Housing	High density polyethylene
Prefilter	Borosilicate glass fiber
Membrane	
LG, LCR	Hydrophilic PTFE
HV	Durapore [®] (PVDF)
GN, HN	Nylon
Dimensions	
inlet to outlet	21 mm (0.83 in.)
diameter	30 mm (1.18 in.)
filtration surface area	3.9 cm ² (0.61 in ²)
Pore size	
LG, GN	0.2 μm
LCR, HV, HN	0.45 μm

Specifications, continued

Temperature limit	45 °C (113 °F) maximum
Connections	Female Luer-Lok™ inlet, male Luer-slip outlet
Pressure limit at 25 °C	≤ 100 psi (6.9 bar) inlet and differential
Filtration volume	≤ 100 mL
Hold-up volume	≤ 100 µL (membrane); ≤ 250 µL (membrane with prefilter)

Product Ordering Information

Millex Automation Compatible (AC) Filter Units

Filter Unit	Description	Qty/Pk	Catalogue No.
Millex-PB	1.0 µm glass fiber	200 (8x25)	SLPB DZ5 NZ
		1000	SLPB DZ5 NK
Millex-LG	0.2 µm hydrophilic PTFE	200 (8x25)	SLLG DZ5 NZ
		1000	SLLG DZ5 NK
Millex-LCR	0.45 µm hydrophilic PTFE	200 (8x25)	SLCR DZ5 NZ
		1000	SLCR DZ5 NK
Millex-LCR/PB	0.45 µm hydrophilic PTFE with 1.0 µm glass fiber prefilter	200 (8x25)	SLCR BZ5 NZ
		1000	SLCR BZ5 NK
Millex-HV	0.45 µm Durapore PVDF membrane	200 (8x25)	SLHV DZ5 NZ
		1000	SLHV DZ5 NK
Millex-HV/PB	0.45 µm Durapore PVDF membrane with 1.0 µm glass fiber	200 (8x25)	SLHV BZ5 NZ
		1000	SLHV BZ5 NK
Millex-GN	0.2 µm nylon	200 (8x25)	SLGN DZ5 NZ
		1000	SLGN DZ5 NK
Millex-HN	0.45 µm nylon	200 (8x25)	SLHN DZ5 NZ
		1000	SLHN DZ5 NK
Millex-HN/PB	0.45 µm nylon with 1.0 µm glass fiber prefilter	200 (8x25)	SLHN BZ5 NZ
		1000	SLHN BZ5 NK

Product Ordering Information, continued

Millex High Particulate Filtration (HPF) Filter Units

Filter Unit	Description	Qty/Pk	Catalogue No.
Millex-LG	0.2 µm hydrophilic PTFE with graduated multi-layer glass fiber prefilter	50	SLLG M25 NS
		1000	SLLG M25 NK
Millex-LCR	0.45 µm hydrophilic PTFE with graduated multi-layer glass fiber prefilter	50	SLCR M25 NS
		1000	SLCR M25 NK
Millex-HV	0.45 µm Durapore PVDF membrane with graduated multi-layer glass fiber prefilter	50	SLHV M25 NS
		200 (8x25)	SLHV MZ5 NZ
		1000	SLHV M25 NK
Millex-GN	0.2 µm nylon with graduated multi-layer glass fiber prefilter	50	SLGN M25 NS
		1000	SLGN M25 NK
Millex-HN	0.45 µm nylon with graduated multi-layer glass fiber prefilter	50	SLHN M25 NS
		200 (8x25)	SLHN MZ5 NZ
		1000	SLHN M25 NK

Technical Assistance

For more information, contact the Millipore office nearest you. In the U.S., call **1-800-MILLIPORE** (1-800-645-5476). Outside the U.S., see your Millipore catalogue for the phone number of the office nearest you or go to our web site at www.millipore.com/offices for up-to-date worldwide contact information. You can also visit the tech service page on our web site at www.millipore.com/techservice.

HPLC Certification

The Millex-LG, -LCR, -GN, and -HN filter units are tested for UV-absorbing extractables. HPLC analysis of a 1 mL volume of acetonitrile and 1 mL volume of water filtered with the 25 mm units show no peaks greater in intensity than 0.004 AUFS (after the column frontal volume) at either 214 nm or 254 nm. Tested samples are collected after discarding the first 1 mL of solvent, as recommended in the “Chemical Compatibility” section.

Representative samples of all lots manufactured are tested.

Standard Warranty

Millipore Corporation (“Millipore”) warrants its products will meet their applicable published specifications when used in accordance with their applicable instructions for a period of one year from shipment of the products. **MILLIPORE MAKES NO OTHER WARRANTY, EXPRESSED OR IMPLIED. THERE IS NO WARRANTY OF MERCHANTABILITY OR FITNESS FOR A PARTICULAR PURPOSE.** The warranty provided herein and the data, specifications and descriptions of Millipore products appearing in Millipore’s published catalogues and product literature may not be altered except by express written agreement signed by an officer of Millipore. Representations, oral or written, which are inconsistent with this warranty or such publications are not authorized and if given, should not be relied upon.

In the event of a breach of the foregoing warranty, Millipore’s sole obligation shall be to repair or replace, at its option, the applicable product or part thereof, provided the customer notifies Millipore promptly of any such breach. If after exercising reasonable efforts, Millipore is unable to repair or replace the product or part, then Millipore shall refund to the customer all monies paid for such applicable product or part. **MILLIPORE SHALL NOT BE LIABLE FOR CONSEQUENTIAL, INCIDENTAL, SPECIAL OR ANY OTHER INDIRECT DAMAGES RESULTING FROM ECONOMIC LOSS OR PROPERTY DAMAGE SUSTAINED BY ANY CUSTOMER FROM THE USE OF ITS PRODUCTS.**

