

:\DWGS\CSD-209050

THIS DRAWING CONTAINS CONFIDENTIAL INFORMATION AND IS A COPYRIGHT OF DWK LIFE SCIENCES INC. IT MAY NOT BE DUPLICATED FOR ANY PURPOSE IN WHOLE OR IN PART WITHOUT THE EXPRESS WRITTEN CONSENT OF DWK LIFE SCIENCES INC. ALL RIGHTS RESERVED. ELECTRONIC OR PAPER COPIES OF THIS PRINT OUTSIDE OF DWK LIFE SCIENCES SYSTEM ARE UNCONTROLLED AND ARE FOR REFERENCE ONLY UNLESS OTHERWISE STAMPED.

THIRD ANGLE PROJECTION

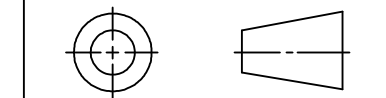

PRODUCT COMPONENTS

ITEM	QTY	DESCRIPTION
1.	24	1000 ML BTL, NM RD, HDPE NAT
2.	24	38MM STAR CAP, PP, NAT $\Delta/B$

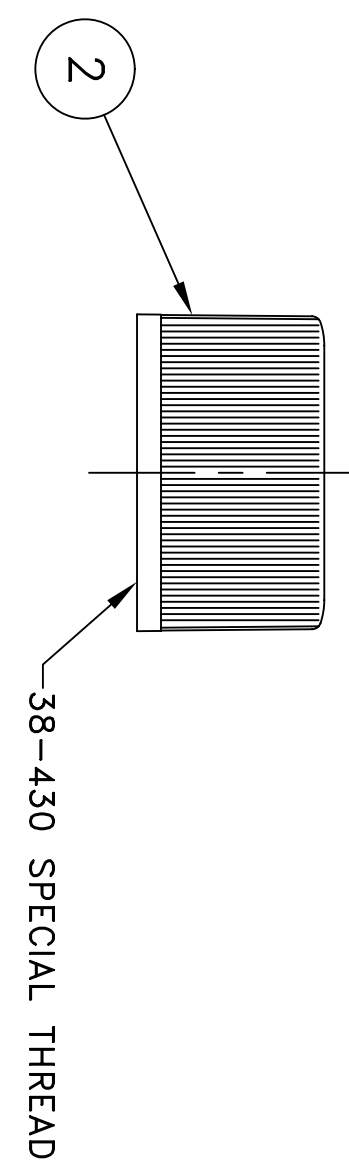
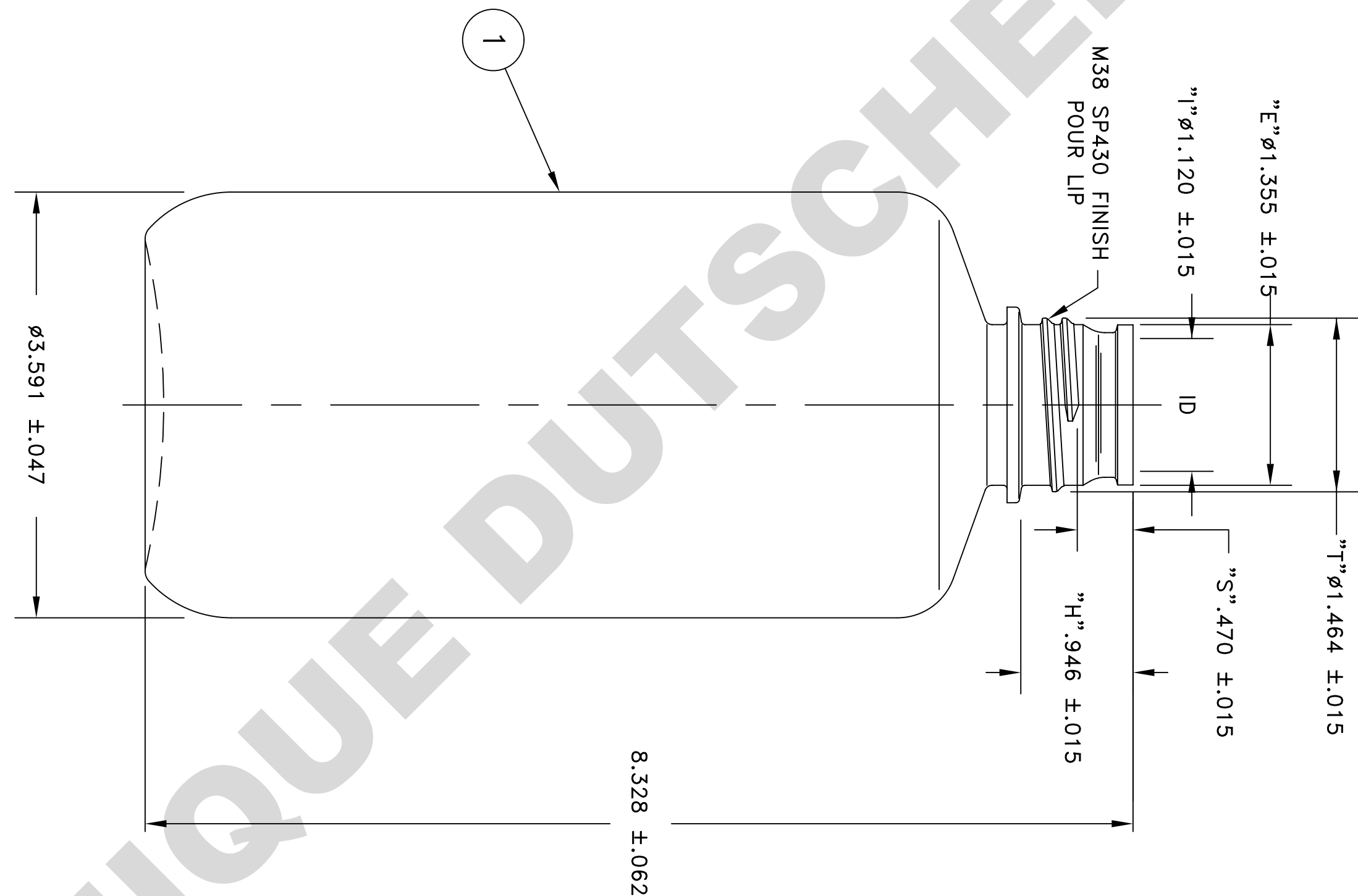
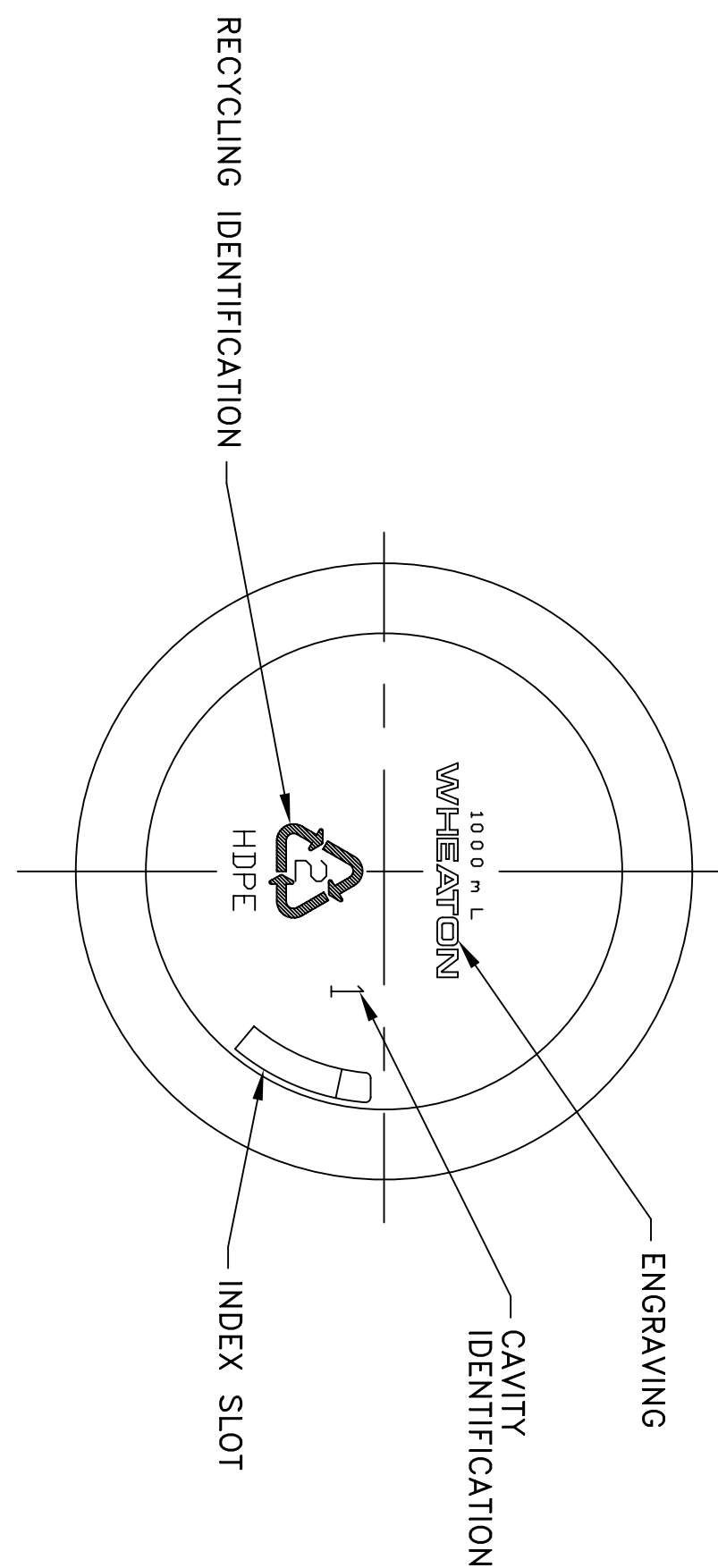

BOTTLE MATERIAL: NATURAL HIGH DENSITY POLYETHYLENE  
CAP MATERIAL: NATURAL POLYPROPYLENE

2.	APPROXIMATE WEIGHTS: BOTTLE 69.7 $\pm$ 3.0 grams, CAP 7.8 $\pm$ 0.8 grams.
1.	DIMENSIONS ARE IN INCHES.

-----NOTES-----

TITLE	1000mL STAR BTL, NM HDPE NAT, 38-430 CAP	DATE DRAWN	08/01/06	PROJ.#	-	REVISED TO DWK STDS	12/15/20 EL
DRAWN BY	B. LLOYD	CHECKED BY	TRJ 8/3/06	APPROX. WGT.	B	20080522085119	12/17/08 BL
CAPACITY	1078.5 $\pm$ 20.0ml OVERFLOW	AUTHORIZED	CJM 8/3/06	REV	E.C.N. #		DATE
FINISH	M38 SP430 POUR LIP	DURAN WHEATON KIMBLE 1501 North 10th Street   Millville, NJ 08332-2038   USA		DWG. NO: c- CSD-209050			
SCALE: UNLESS NOTED FULL DO NOT SCALE THIS DRAWING							