

REV	ECN NO.	DATE	BY	CAD	APPD	DESCRIPTION OF REVISION
0	SI-8012	08-15-00	DHG	DHG	[Signature]	RELEASED FOR PRODUCTION

BILL OF MATERIALS			
ITEM NO.	PART NO.	PART DESCRIPTION	QTY
1	105119	STAINLESS STEEL ADJUSTABLE LEG ASSEMBLY	4
2	117027	1-3/4" SQUARE PLASTIC TUBING PLUG	4
3	190669-16-1	MODULAR INCUBATOR STAND BASE	1

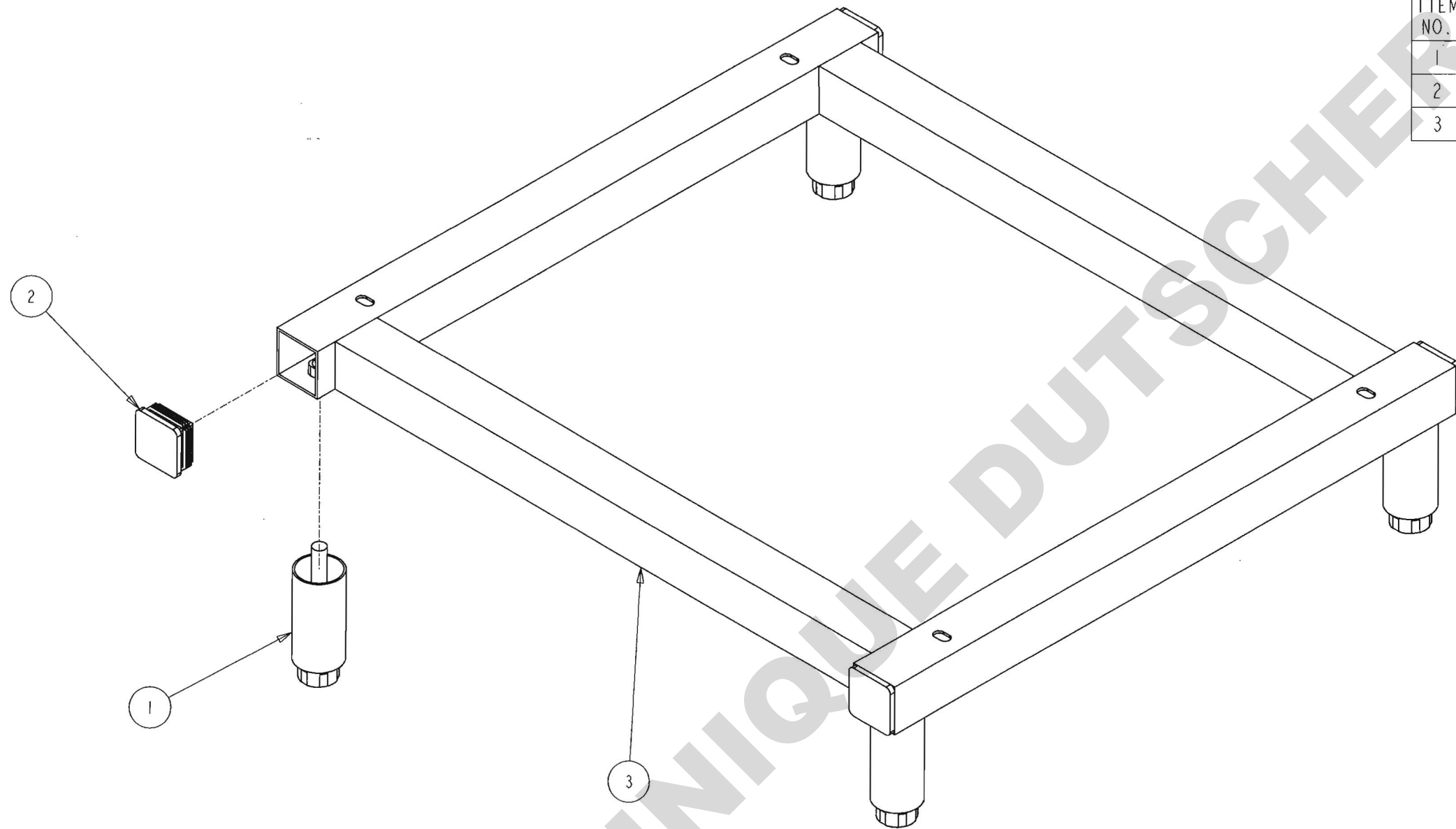
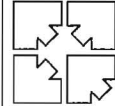

THIS DOCUMENT CONTAINS PROPRIETARY INFORMATION AND SUCH INFORMATION IS NOT TO BE DISCLOSED TO OTHERS FOR ANY PURPOSE NOR USED FOR MANUFACTURING PURPOSE WITHOUT WRITTEN PERMISSION FROM FORMA SCIENTIFIC		MODEL/PART NAME: MODULAR WJ STAND	
		DWG TITLE: MODULAR WATER JACKET STAND	
DWN: DHG	CAD: DHG	APPD: [Signature]	DATE: 08-15-00 SCALE: 0.250
		MATERIAL: N/A	
		PAINT: N/A	
 Forma Scientific Box 649, Marietta, Ohio 45750		TOLERANCE UNLESS OTHERWISE SPECIFIED ANGLES: DECIMAL: .XX=± .xxx=±	DRAWING NUMBER 190648-01-1 SIZE B